



WORKY[®]

POZZETTI

FLOOR TRAPS

REGARDS D'ASPIRATION

BODENVERSCHLÜSSE

POCETAS



GFT
Pag. 4



GFTBR-X
Pag. 8



GFTBR
Pag. 10



GFTB
Pag. 12

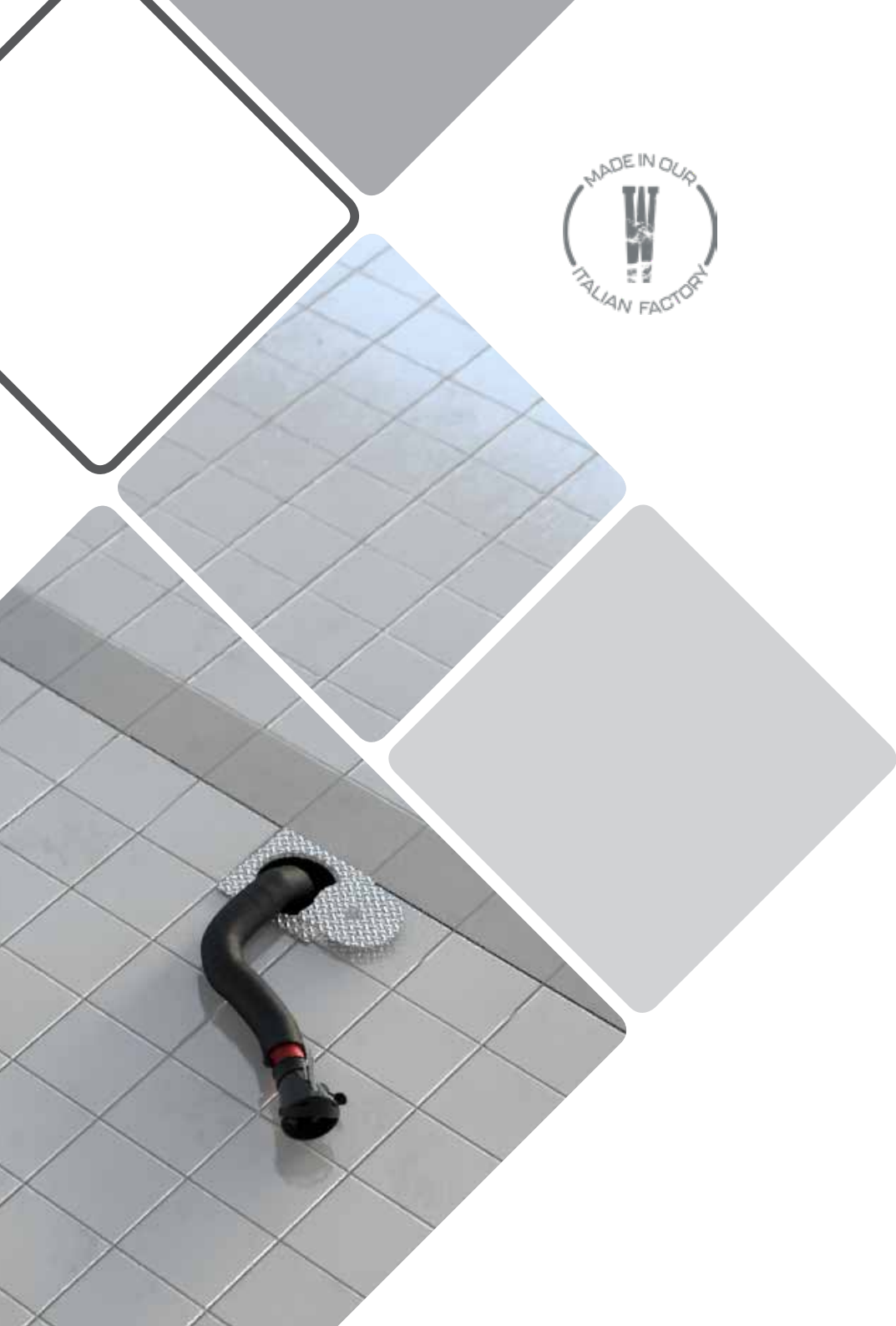





GFT



 I pozzetti sottopavimento rappresentano la soluzione più elegante e meno invasiva della gamma WORKY per l'aspirazione dei gas di scarico. Indipendentemente da quale tecnologia venga scelta, il risultato sarà sempre di avere un impianto performante, ben realizzato ma discreto e poco invasivo per l'estetica e la funzionalità dell'officina. Richiedi la configurazione più vicina alle tue esigenze e WORKY sarà felice di realizzare il tuo impianto quasi "invisibile".

 Floor traps represent the most elegant and least invasive solution in the WORKY range for exhaust gas extraction. Regardless of the technology chosen, the result will always be a high-performance system, well-built yet discreet, preserving the workshop's aesthetics and functionality. Request the configuration that best suits your needs, and WORKY will be happy to create your almost "invisible" system.

 Les regards d'aspiration représentent la solution la plus élégante et la moins intrusive de la gamme WORKY pour l'extraction des gaz d'échappement. Quelle que soit la technologie choisie, le résultat sera toujours un système performant, bien conçu, discret et peu invasif pour l'esthétique et la fonctionnalité de l'atelier. Demandez la configuration la plus adaptée à vos besoins et WORKY sera heureux de réaliser votre installation presque "invisible".

 Bodenverschlüsse stellen die eleganteste und unauffälligste Lösung im WORKY-Sortiment zur Absaugung von Abgasen dar. Unabhängig von der gewählten Technologie erhalten Sie stets eine leistungsstarke, sauber integrierte Anlage, die weder die Optik noch die Funktionalität Ihrer Werkstatt beeinträchtigt. Fordern Sie die Konfiguration an, die Ihren Anforderungen am nächsten kommt – WORKY freut sich, Ihr nahezu „unsichtbares“ System zu realisieren.

 Las pocetas representan la solución más elegante y menos invasiva de la gama WORKY para la aspiración de gases de escape. Independientemente de la tecnología elegida, el resultado será siempre un sistema eficiente, bien diseñado, discreto y poco intrusivo para la estética y funcionalidad del taller. Solicita la configuración más adecuada a tus necesidades y WORKY estará encantada de crear tu sistema casi "invisible".

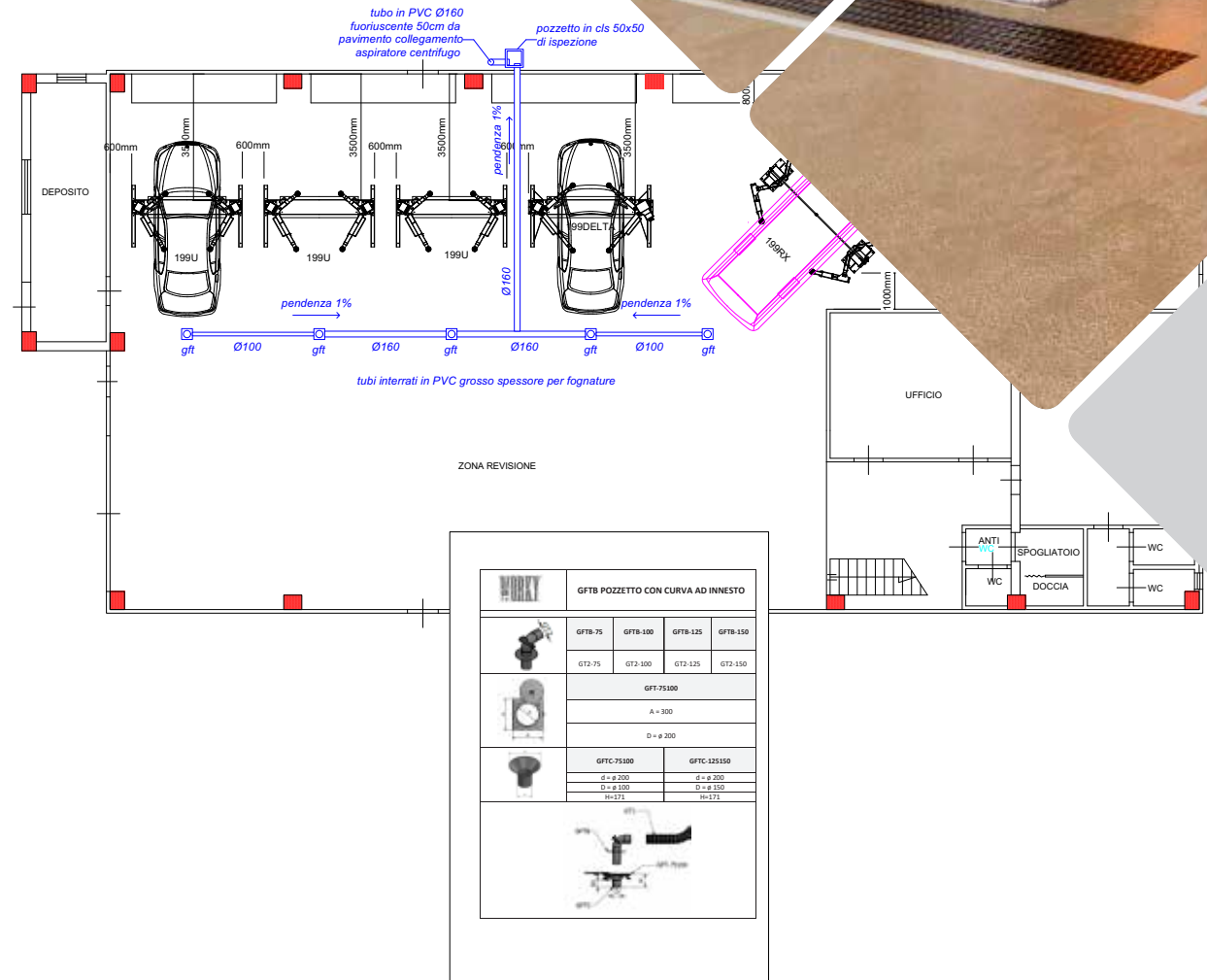

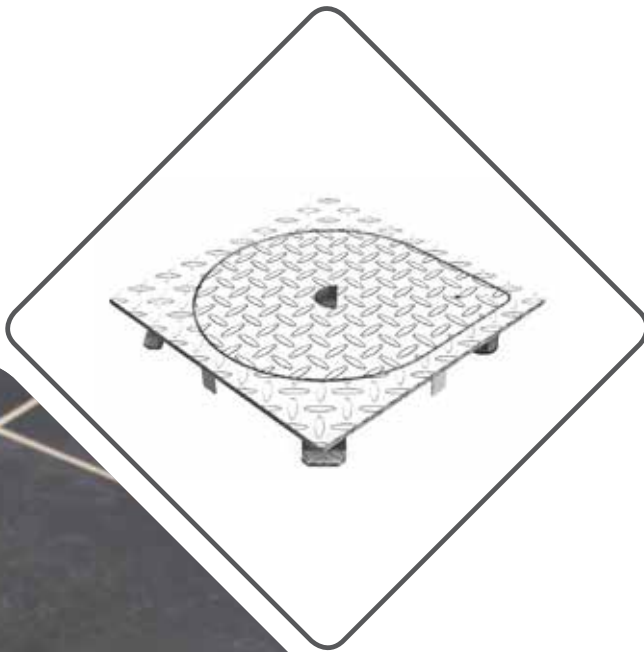

GFT



 Spessa flangia in acciaio zincato con mandorlatura antiscivolo sulla parte superiore, perno di rotazione per facilitarne l'apertura pur mantenendo il coperchio attaccato alla flangia

 Thick galvanized steel flange with anti-slip tread plate on the upper surface, and pivot pin to facilitate opening while keeping the cover attached to the flange.

 Bride épaisse en acier galvanisé avec surface supérieure antidérapante à damiers, et axe de rotation pour faciliter l'ouverture tout en maintenant le couvercle fixé à la bride.

 Dicke verzinkte Stahlflansch mit rutschhemmender Riffelung auf der Oberseite und Drehbolzen zur erleichterten Öffnung, wobei der Deckel an der Flansch befestigt bleibt.

 Brida gruesa de acero galvanizado con superficie superior antideslizante con relieve, y eje de giro para facilitar la apertura manteniendo la tapa unida a la brida.

CODE	DIMENS.	APPLIC.
GFT-75100	300 X 300 - Ø 200 MM	GFTBR - GFTB - GFTC
GFT-125150	360 X 360 - Ø 260 MM	GFTBR-100G - 125 - 150
GFT-400	400 X 400 - Ø 324 MM	GFTBR-X...



via Masaccio, 15
42124 Reggio Emilia (RE) ITALY
Tel. +39 0522 1545193
Fax +39 0522 1546451
vendite@worky-italy.com
sales@worky-italy.com
www.worky-italy.com

GFT-400 - technical datasheet

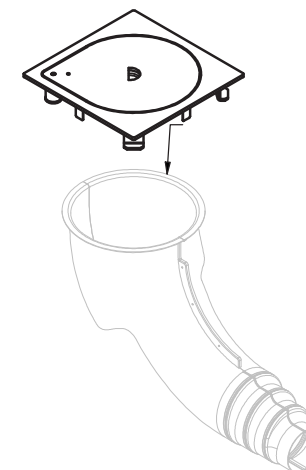
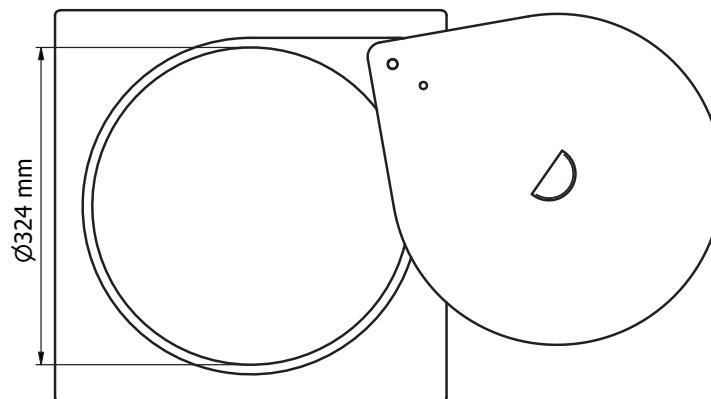
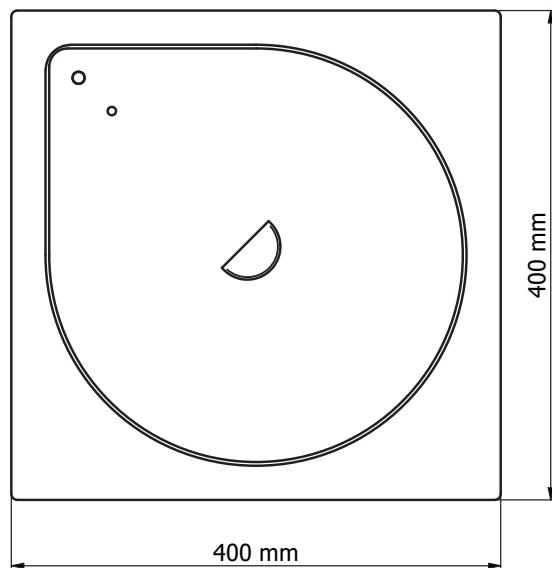
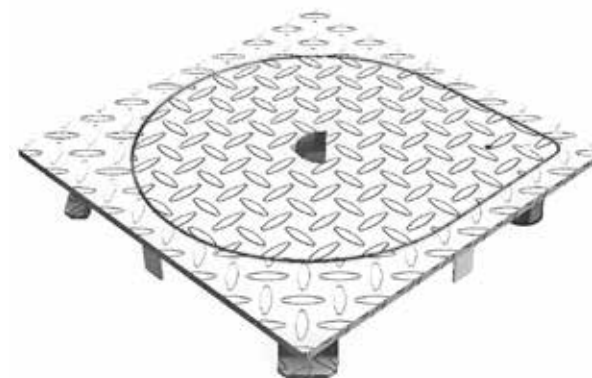
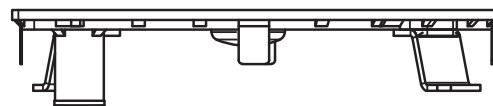
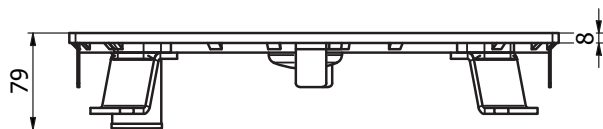



GFTBR-X



 Cono sottopavimento in materiale plastico per l'alloggiamento di tutte le bocchette in gomma sia per auto che per camion in quanto il collegamento al tubo in PVC è a sezione scalare per collegarla al diametro giusto.

 Underfloor cone made of plastic material designed to house all rubber nozzles, both for cars and trucks, thanks to its stepped connection section that allows coupling with the correct PVC hose diameter.

 Cône encastré en matériau plastique conçu pour accueillir toutes les buses en caoutchouc, aussi bien pour voitures que pour camions, grâce à son raccord à section étagée permettant de le connecter au bon diamètre de tuyau en PVC.

 Unterflurkonus aus Kunststoffmaterial zur Aufnahme aller Gummidüsen für Pkw und Lkw, da der Anschluss an das PVC-Rohr eine gestufte Form hat, um den passenden Durchmesser anzuschließen.

 Cono empotrado en el suelo fabricado en material plástico, diseñado para alojar todas las boquillas de goma tanto para coches como para camiones, gracias a su conexión escalonada que permite adaptarse al diámetro correcto del tubo de PVC.

CODE	FLANGE	APPLIC.
GFTBR-X75	GFT-400	ALL GRN, GON MODELS
GFTBR-X100	GFT-400	ALL GRN, GON MODELS
GFTBR-X125	GFT-400	ALL GRN, GON, GRTN MODELS
GFTBR-X150	GFT-400	ALL GRN, GON, GRTN MODELS



via Masaccio, 15
42124 Reggio Emilia (RE) ITALY
Tel. +39 0522 1545193
Fax +39 0522 1546451
vendite@worky-italy.com
sales@worky-italy.com
www.worky-italy.com

GFTBR-X - technical datasheet

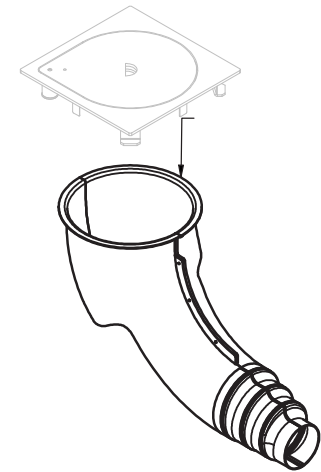
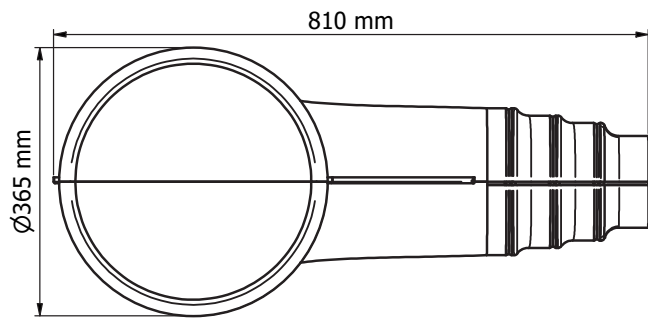
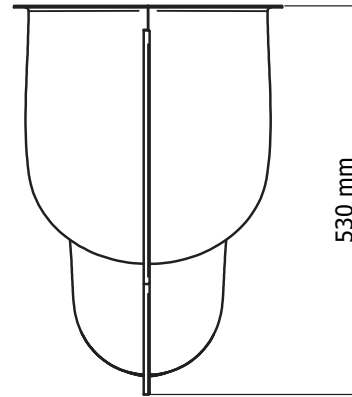
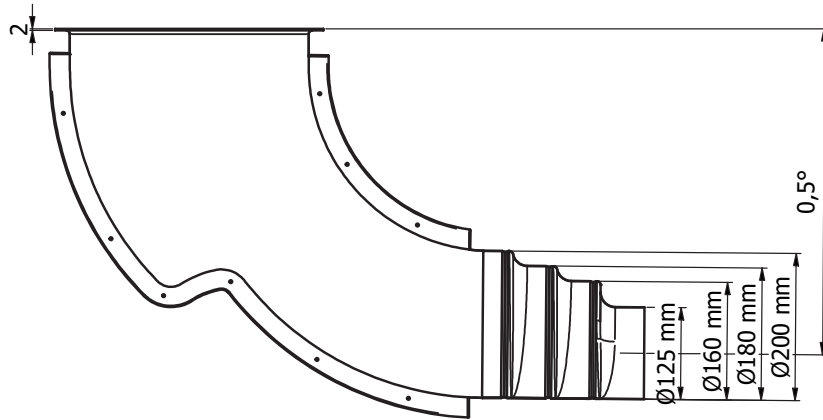



GFTBR



 Cono sottopavimento in lamiera zincata per l'alloggiamento di bocchette in gomma per auto e camion (senza pinza). Da raccordare al tubo in PVC sottopavimento con una curvetta a 45°.

 Galvanized steel underfloor cone for housing rubber nozzles for cars and trucks (without clamp). To be connected to the underfloor PVC pipe with a 45° elbow.

 Cône encastré en tôle galvanisée pour l'emplacement d'entonnoirs en caoutchouc pour voitures et camions (sans pince). À raccorder au tuyau en PVC au moyen d'un coude à 45°.

 Unterflurkonus aus verzinktem Blech zur Aufnahme von Gummitrichtern für Pkw und Lkw (ohne Klemme). Mit dem PVC-Unterflurrohr über ein 45°-Bogenstück verbinden.

 Cono de chapa galvanizada para alojar embudos de goma para coches y camiones (sin pinza). Para conectar al tubo de PVC bajo el suelo mediante una curva de 45°.

CODE	Ø FLEX.	APPLIC.
GFTBR-75	75 MM	GRC-75K - GRNM-16075 - GRNKM-16075
GFTBR-100	100 MM	GRC-100K - GRNM-160100 - GRNKM-160100
GFTBR-100G	100 MM	GRNGM-160100
GFTBR-125	125 MM	GRTN-125 - GRTN-125M - GRTN125K
GFTBR-150	150 MM	GRTN-150 - GRTN-150M - GRTN-150K

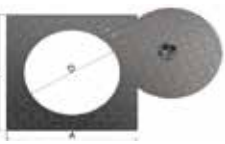
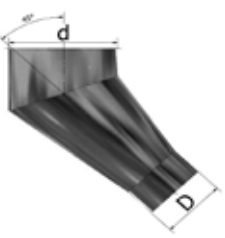
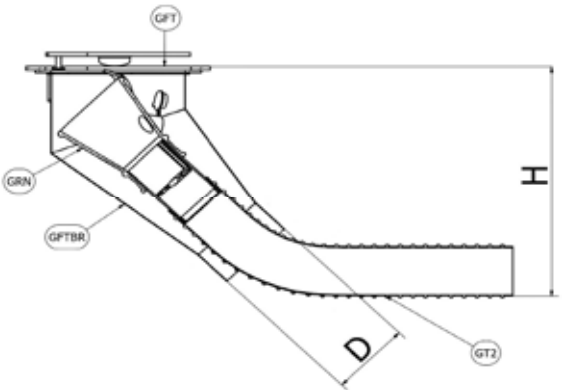

GFT

	GT2-75	GT2-100		GT2-125	GT2-150
	GRNM-16075	GRNM-160100	GRNGM-160100	GRNGM-160125	GRTN-150
	GRNTM-16075	GRNTM-160100	GON-100	GRTN-125	GRTN-150K
	GRNKM-16075	GRNKM-160100	GON-100K	GRTN-125K	
			GRTN-100	GRTN-125MG	
			GRTN-100K		
	GFT-75100		GFT-125150		
	A = 300 mm		A = 360 mm		
	D = Ø 200 mm		D = Ø 260 mm		
	GFTBR-75	GFTBR-100	GFTBR-100G	GFTBR-125	GFTBR-150
	d = Ø 200 mm	d = Ø 200 mm	d = Ø 260 mm	d = Ø 260 mm	d = Ø 260 mm
	D = Ø 125 mm	D = Ø 160 mm	D = Ø 160 mm	D = Ø 180 mm	D = Ø 200 mm
	H = 540 mm	H = 560 mm	H = 530 mm	H = 545 mm	H = 560 mm
					

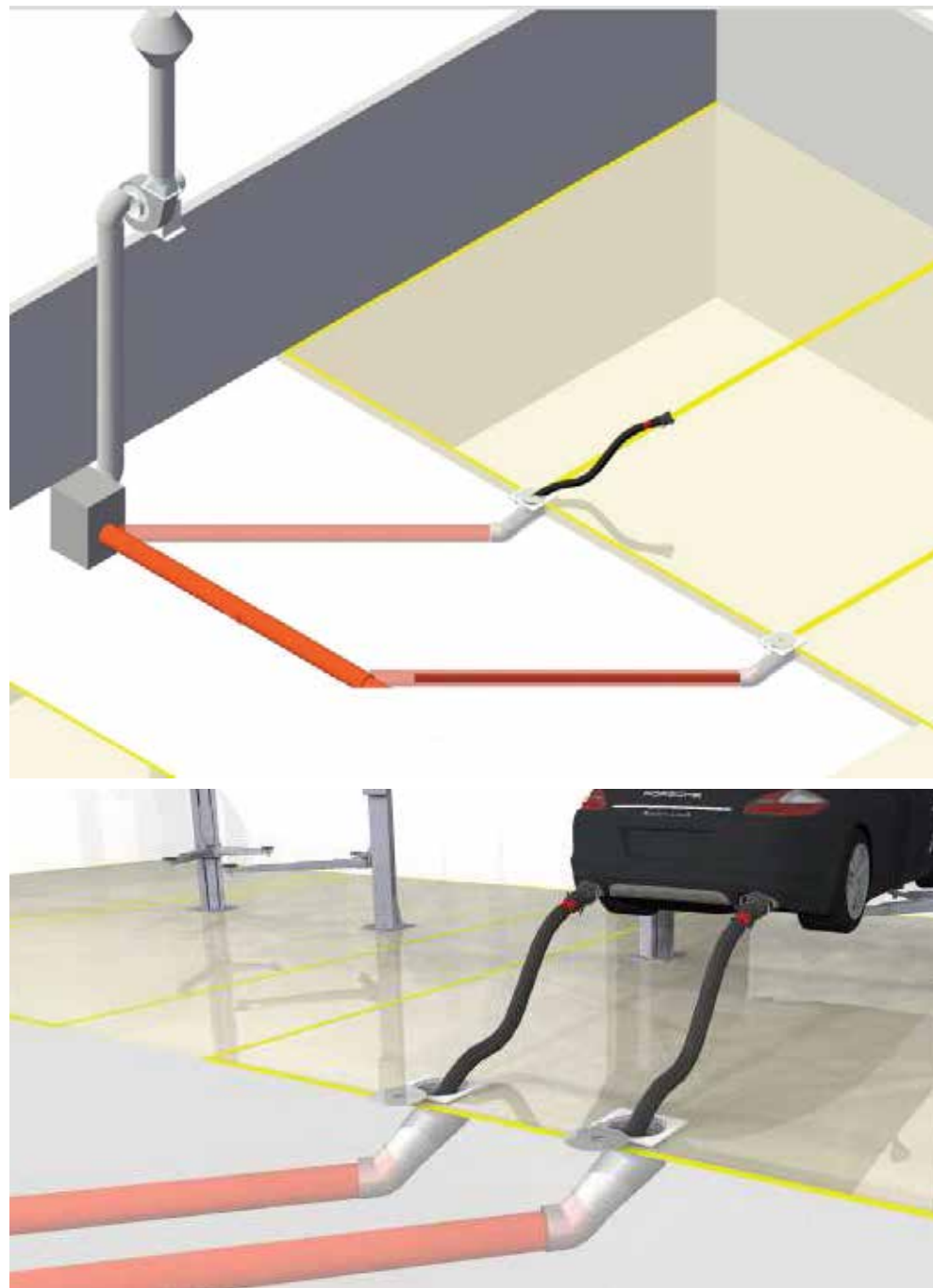



GFTB



 Curva ad innesto per pozzetti sottopavimento, da utilizzare con tubo flessibile e bocchetta idonea ad agganciarsi ai veicoli dai quali aspirare i gas di scarico.

 Push-fit elbow for floor traps, to be used with flexible hose and a nozzle suitable for connecting to vehicles from which to extract exhaust gases.

 Coude à emboîtement pour regards d'aspiration, à utiliser avec un tuyau flexible et un entonnoir adapté pour se raccorder aux véhicules dont on doit aspirer les gaz d'échappement.

 Steckbogen für Bodenverschlüsse, zur Verwendung mit einem flexiblen Schlauch und einem geeigneten Trichter zum Anschluss an Fahrzeuge, aus denen Abgase abgesaugt werden sollen.

 Codo de encaje para pocetas, para usar con manguera flexible y un embudo adecuado para conectarse a los vehículos de los que se van a aspirar los gases de escape.

CODE	Ø FLEX.	APPLIC.	CONE
GFTB-75	75 MM	ONLY WITH GFT-75100	GFTC-75100
GFTB-100	100 MM	ONLY WITH GFT-75100	GFTC-75100
GFTB-125	125 MM	ONLY WITH GFT-75100	GFTC-125150
GFTB-150	150 MM	ONLY WITH GFT-75100	GFTC-125150



GFTB



GFTB-75/9005

GFTB-100/9005

GFTB-125/9005

GFTB150/9005

GT2-75

GT2-100

GT2-125

GT-150

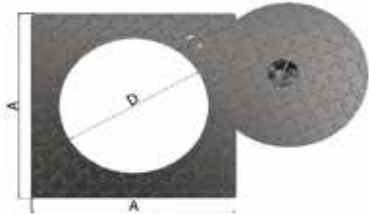

GFT-75100

A= 300 mm

d= Ø200 mm



GFTC-75100

GFTC-125150

d= Ø200 mm

d= Ø200 mm

D= Ø100 mm

D= Ø150 mm

H=171 mm

H=171 mm

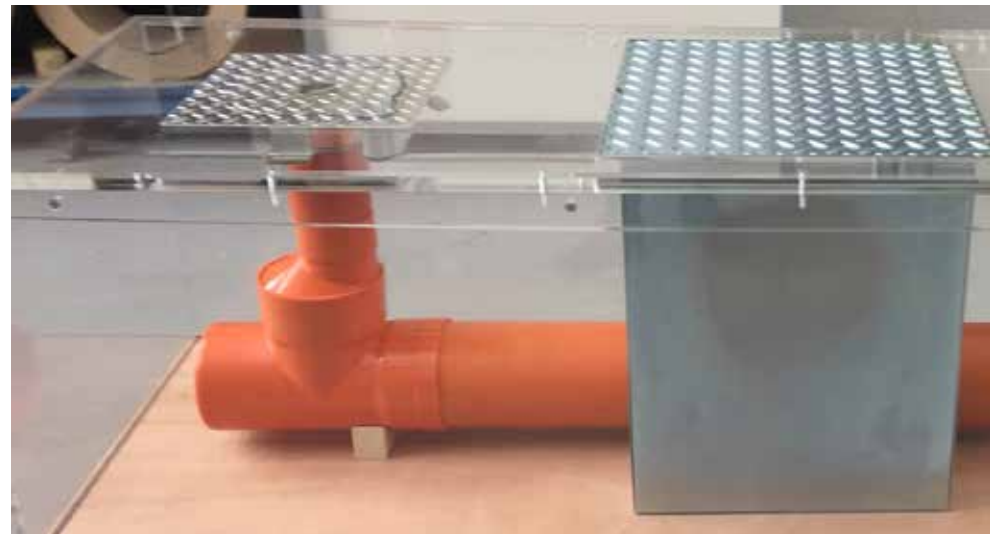
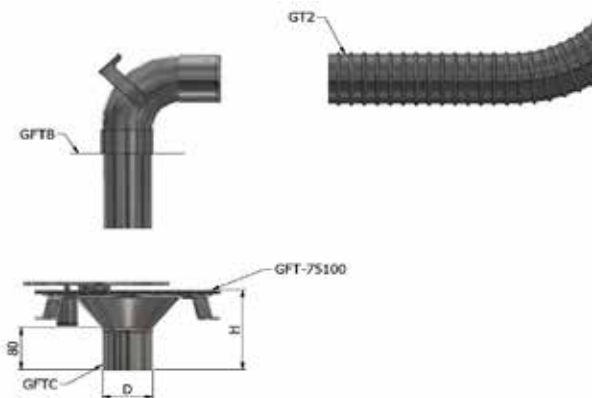



via Masaccio, 15
42124 Reggio Emilia (RE) ITALY
Tel. +39 0522 1545193
Fax +39 0522 1546451
vendite@worky-italy.com
sales@worky-italy.com
www.worky-italy.com

GFTBR-X + GFT-400 OPERATIVE LAYOUT

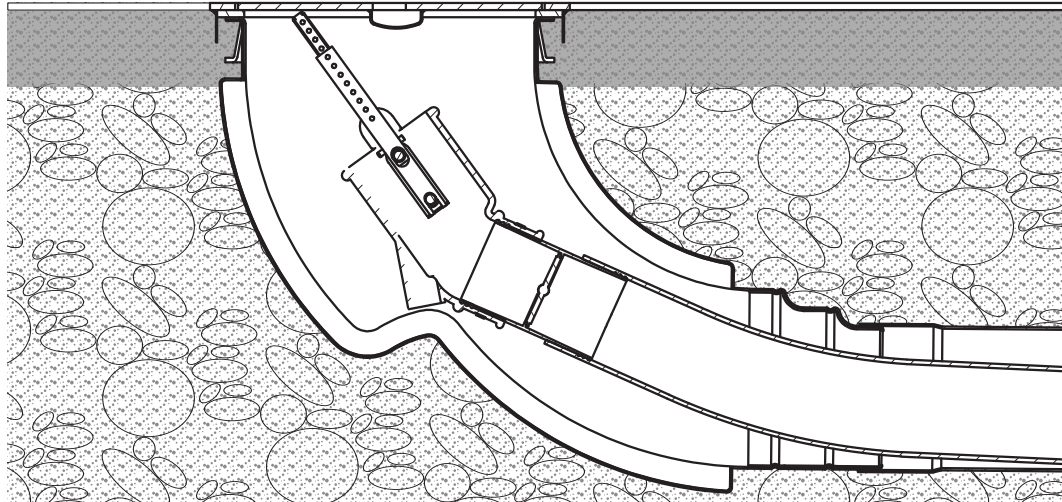



CAT. ACCESS. CAT. VENTILAT. CAT. BOCCHETTE



SCAN THE QR CODE
DOWNLOAD THE
CATALOGUE



SCAN THE QR CODE
DOWNLOAD THE
CATALOGUE



SCAN THE QR CODE
DOWNLOAD THE
CATALOGUE



WORRY®

WORKY®

WORKY Headquarters and Production

Via Masaccio, 15 - Z.I. Mancasale
42124 - REGGIO EMILIA (RE) ITALY

Tel. **+39-0522-1545193**

Fax. **+39-0522-1546451**

sales@worky-italy.com

vendite@worky-italy.com

www.worky-italy.com

WORKY North America Inc.

112 South Tryon Street
Suite 1130 Charlotte, North Carolina
28284 USA

Tel **+1 (305) 705 5017**

www.deaworkyna.com



Inquadra il QR Code e scopri il nostro sito!
Frame the QR Code to discover our website!



Seguici su / Follow us on:



QUALITY CERTIFIED ISO 9001:2015