



# WORKY<sup>®</sup>

DISTRIBUZIONE FLUIDI

OIL DISPENSING

DISTRIBUTION FLUIDES

FLUSSIGKEITVERS.

DISTRIBUCION DE  
FLUIDOS



**MULTIPLO**

**Pag. 4**



**MULTIPLO-XL**

**Pag. 14**



**MONOPOST**

**Pag. 20**

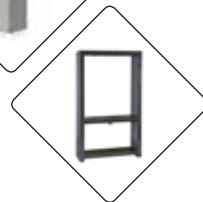



**FRMF**

**Pag. 26**





# MULTIPLLO



 Il portale multifunzione MULTIPLLO rappresenta la struttura più grande in gamma WORKY per la distribuzione di fluidi ed energie in officine di riparazione per mezzi industriali. Le grandi possibilità di alloggiare equipaggiamento idoneo alla distribuzione fluidi e la possibilità di integrare l'aspirazione dei gas di scarico ne fanno una soluzione imprescindibile quando non si possano fissare queste attrezzature al soffitto dell'officina. Disponibile in versioni senza aspirazione, con alloggiamento per 1 o due arrotolatori, MULTIPLLO può essere anche realizzato in versione universale, ossia adatto ad accogliere diverse tipologie di arrotolatori.

 The MULTIPLLO multifunctional portal is the largest structure in the WORKY range for the distribution of fluids and energy in industrial vehicle repair workshops. Its wide capacity to house equipment for fluid distribution, combined with the possibility of integrating exhaust gas extraction, makes it an essential solution whenever these systems cannot be installed on the workshop ceiling. Available in versions without extraction, with housing for one or two hose reels, MULTIPLLO can also be manufactured in a universal version, suitable for accommodating different types of hose reels.

 Le portique multifonction MULTIPLO représente la plus grande structure de la gamme WORKY pour la distribution de fluides et d'énergies dans les ateliers de réparation de PL. Sa grande capacité à accueillir des équipements adaptés à la distribution de fluides, ainsi que la possibilité d'intégrer l'aspiration des gaz d'échappement, en font une solution incontournable lorsque ces installations ne peuvent pas être fixées au plafond de l'atelier. Disponible en versions sans aspiration, avec logement pour un ou deux enrouleurs, MULTIPLO peut également être réalisé en version universelle, c'est-à-dire adapté à recevoir différents types d'enrouleurs.

 Das MULTIPLO-Multifunktionsportal ist die größte Struktur im WORKY-Sortiment für die Verteilung von Flüssigkeiten und Energie in Werkstätten für Nutzfahrzeugreparaturen. Die große Möglichkeit, geeignete Geräte für die Flüssigkeitsverteilung unterzubringen, sowie die Option, eine Abgasabsaugung zu integrieren, machen es zu einer unverzichtbaren Lösung, wenn diese Systeme nicht an der Werkstattdecke installiert werden können. Erhältlich in Ausführungen ohne Absaugung, mit Platz für eine oder zwei Schlauchaufroller, kann MULTIPLO auch in einer universellen Version gefertigt werden, die für verschiedene Arten von Schlauchaufrollern geeignet ist.

 El portal multifunción MULTIPLO es la estructura más grande de la gama WORKY para la distribución de fluidos y energía en talleres de reparación de vehículos industriales. Su amplia capacidad para alojar equipos adecuados para la distribución de fluidos, junto con la posibilidad de integrar la aspiración de gases de escape, lo convierten en una solución imprescindible cuando estos sistemas no pueden instalarse en el techo del taller. Disponible en versiones sin aspiración, con alojamiento para uno o dos enrolladores, MULTIPLO también puede fabricarse en versión universal, es decir, apto para albergar diferentes tipos de enrolladores.

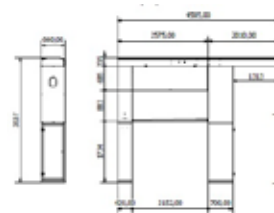

- MULTIPLO  
10 hose reel WORKY + GMR  
- MULTIPLO-U  
10 hose reel + GMR



- MULTIPLO-M  
10 hose reel WORKY + GMR  
- MULTIPLO-UM  
10 hose reel + GMR



- MULTIPLO-SG  
10 hose reel WORKY  
- MULTIPLO-SGU  
10 hose reel



- MULTIPLO-SGM  
10 hose reel WORKY  
- MULTIPLO-SGUM  
10 hose reel



- MULTIPLO-2G  
10 hose reel WORKY + 2 GMR  
- MULTIPLO-2GU  
10 hose reel + 2 GMR

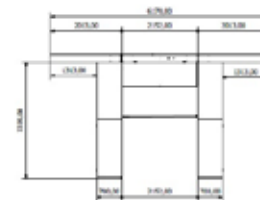



- MULTIPLO-2GM  
10 hose reel WORKY + 2 GMR  
- MULTIPLO-2GUM  
10 hose reel + 2 GMR

# MULTIPLLO



 Portale per la distribuzione di fluidi ed energie con supporto arrotolatore per gas di scarico. Può alloggiare fino ad 10 avvolgitori fino a 15 mt: attrezzabile con banco di lavoro a richiesta.

 Structure for fluid and energy distribution with support for exhaust extraction hose reel. It can welcome up to 10 reels for fluids 15 mt long. Prepared for cabinets on demand.

 Portique pour la distribution des fluides et énergies, avec support pour l'enrouleur pour gaz d'échappement. Possibilité d'installer jusqu'à 10 enrouleurs de 15m. Prévu pour établi de travail.

 Standsäule für Flüssigkeit, Energieversorgung, und einen Schlauchaufroller für Abgas. Es kann bis 10 Schlauchaufroller 15m lang ausgestattet werden. Werkbank auf Wunsch.

 Pórtico para la distribución de fluidos, energías y soporte para enrollador de aspiración gas de escape. Está preparado para max. 10 enrolladores de 15 m. Banco de trabajo bajo petición.

CODE	DIM (mm)	nr. reels	BIG LEGS	GAS
<b>MULTIPLO</b>	4585 X 660 X H3537	10 WORKY	1	1x
<b>MULTIPLO-M</b>	4867 X 660 X H3537	10 WORKY	2	1x
<b>MULTIPLO-U</b>	4585 X 660 X H3537	10 (ANY)	1	1x
<b>MULTIPLO-UM</b>	4867 X 660 X H3537	10 (ANY)	2	1x

# WORKY

www.worky-italy.com

A brand of RO & Co S.p.A.  
via Masaccio, 15  
42124 Reggio Emilia (RE) ITALY  
Tel. +39 0522 1545193  
vendite@worky-italy.com  
sales@worky-italy.com

## MULTIPLO - technical datasheet

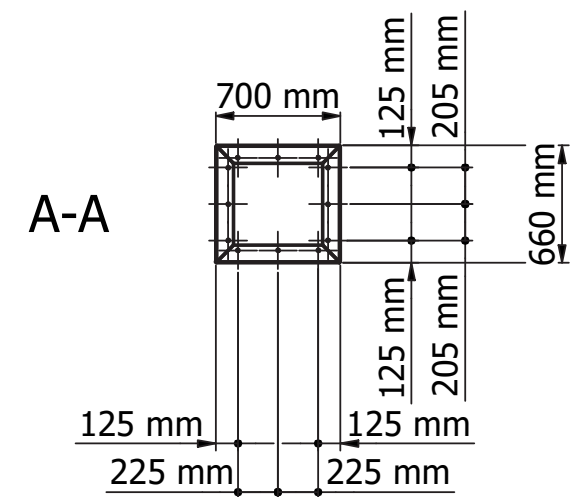
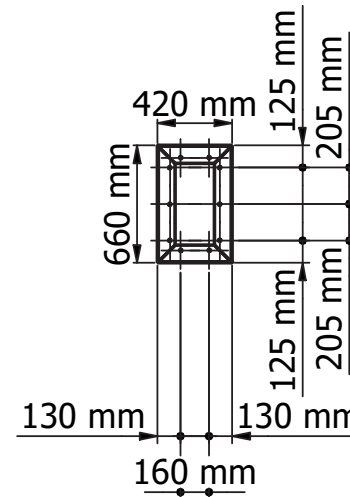
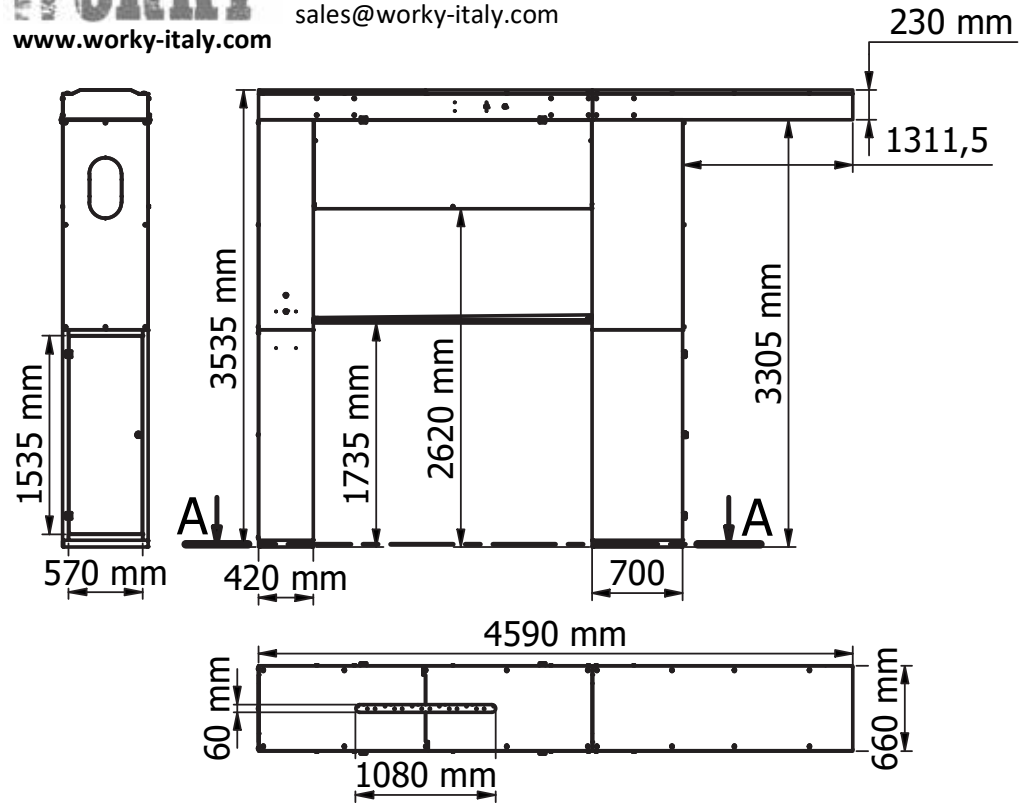



# MULTIPLLO-SG



 Portale per la distribuzione di fluidi ed energie configurabile secondo le necessità dell'officina. Può alloggiare fino ad 10 avvolgitori fino a 15 mt: attrezzabile con banco di lavoro a richiesta.

 Structure for fluid and energy distribution with multiple configurations according to the garage needs. It can welcome up to 10 reels 15 mt long. Prepared for cabinets on demand.

 Portique pour la distribution des fluides et énergies, modulable selon les exigences de l'application. Possibilité d'installer jusqu'à 10 enrouleurs de 15m. Prévu pour établi de travail.

 Standsäule für Flüssigkeit und Energieversorgung, personalisierbar auf Kundenwunsch. Es kann bis 10 Schlauchaufroller 15m lang ausgestattet werden. Werkbank auf Wunsch.

 Pórtico para la distribución de fluidos y energía. Está preparado para max. 10 enrolladores de 15 m. Banco de trabajo bajo petición.

CODE	DIM (mm)	nr. reels	BIG LEGS	GAS
<b>MULTIPLLO-SG</b>	3274 X 660 X H3537	10 WORKY	1	-
<b>MULTIPLLO-SGM</b>	3555 X 660 X H3537	10 WORKY	2	-
<b>MULTIPLLO-SGU</b>	3274 X 660 X H3537	10 (ANY)	1	-
<b>MULTIPLLO-SGUM</b>	3555 X 660 X H3537	10 (ANY)	2	-

MULTIPLO-SG - technical datasheet

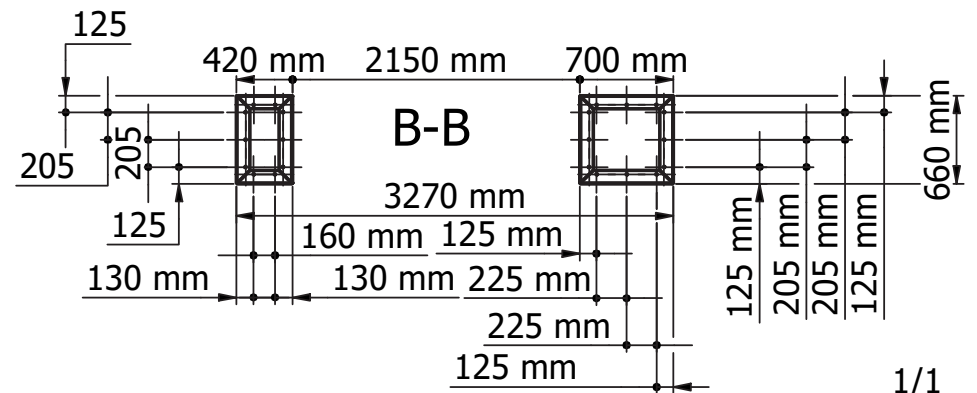
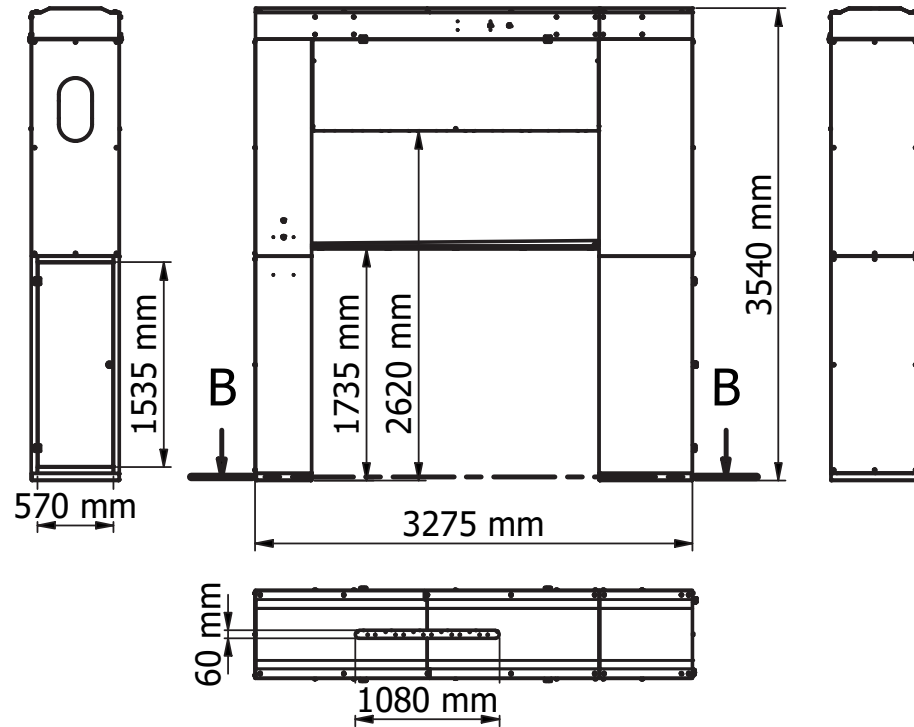



# MULTIPLLO-2G



 Portale per la distribuzione di fluidi ed energie con supporto per 2 arrotolatori gas di scarico. Può alloggiare fino ad 10 avvolgitori fino a 15 mt: attrezzabile con banco di lavoro a richiesta.

 Structure for fluid and energy distribution with support for 2 exhaust extraction hose reels. It can welcome up to 10 reels for fluids 15 mt long. Prepared for cabinets on demand.

 Portique pour la distribution des fluides et énergies, avec support pour deux enrouleurs gaz d'échappement. Possibilité d'installer jusqu'à 10 enrouleurs de 15m. Prévu pour établi de travail.

 Standsäule für Flüssigkeit, Energieversorgung, und Zwei Schlauchaufrollern für Abgas. Es kann bis 10 Schlauchaufroller 15m lang ausgestattet werden. Werkbank auf Wunsch.

 Pórtico para la distribución de fluidos, energías y soporte para dos enrolladores gas de escape. Está preparado para max. 10 enrolladores de 15 m. Banco de trabajo bajo petición.

CODE	DIM (mm)	nr. reels	BIG LEGS	GAS
<b>MULTIPLLO-2G</b>	5898 X 660 X H3537	10 WORKY	1	2x
<b>MULTIPLLO-2GM</b>	6178 X 660 X H3537	10 WORKY	2	2x
<b>MULTIPLLO-2GU</b>	5898 X 660 X H3537	10 (ANY)	1	2x
<b>MULTIPLLO-2GUM</b>	6178 X 660 X H3537	10 (ANY)	2	2x



# MULTIPLLO-PRL

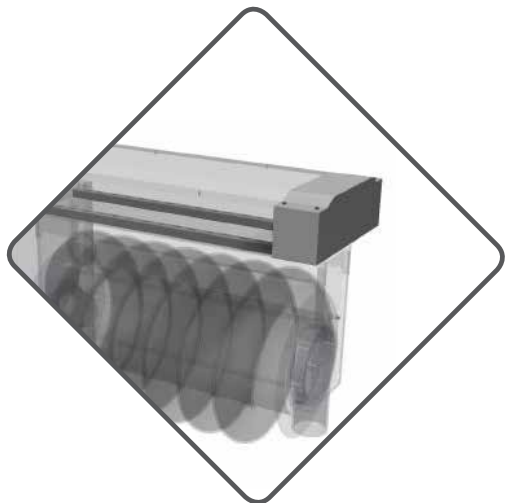

 Prolunga per appendice di supporto arrotolatori per multiplo in modo da alloggiare anche arrotolatori con 15 mt di tubo flessibile.

 Extension for hose reel support bracket for MULTIPLLO, allowing the installation of hose reels with 15 m flexible hose.

 Rallonge pour support d'arrotolateurs du MULTIPLLO, afin de loger également des enrouleurs avec tuyau flexible de 15 m.

 Verlängerung für Halterung der Schlauchaufroller des MULTIPLLO, um auch Aufroller mit 15 m flexiblem Schlauch aufzunehmen.

 Prolongación para soporte de enrolladores del MULTIPLLO, que permite alojar también enrolladores con 15 m de tubo flexible.

CODE	DIM.
<b>MULTIPLLO-PRL</b>	+180 mm

# MULTIPLLO-FDC

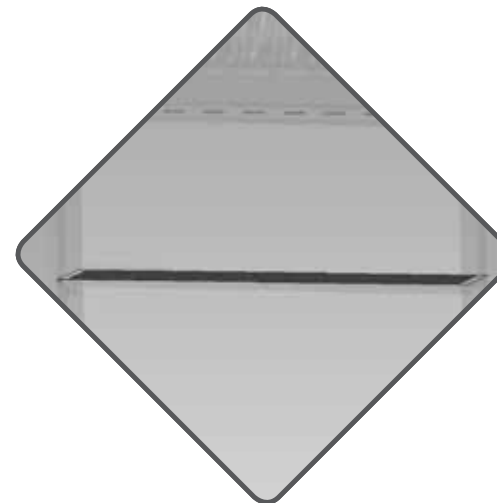

 Vasca raccogli-gocce originariamente del multiplo ma da appendere a parete con 2 staffe metalliche incluse.

 Drip tray originally for MULTIPLLO, to be wall-mounted with 2 included metal brackets.

 Bac de récupération des gouttes, initialement prévu pour le MULTIPLLO, à fixer au mur avec 2 équerres métalliques incluses.

 Tropfwanne ursprünglich für MULTIPLLO, zur Wandmontage mit 2 mitgelieferten Metallhaltern.

 Bandeja recoge-gotas originalmente del MULTIPLLO, para fijar a pared con 2 soportes metálicos incluidos.

CODE	dimensions
<b>MULTIPLLO-FDC</b>	2160 x 400 x h 40 mm

# MULTIPLO-GB

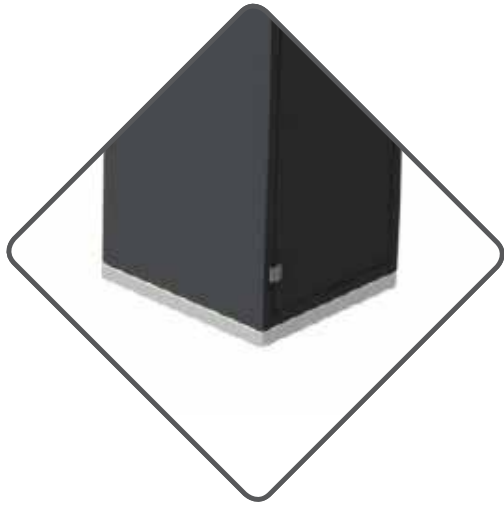

 Base d'appoggio in lamiera zincata per evitare i danni da esposizione prolungata ad un ambiente umido. Accessorio da richiedere prima della produzione del MULTIPLO.

 Galvanized sheet metal support base to prevent damage from prolonged exposure to a humid environment. Accessory to be requested before MULTIPLO production.

 Socle en tôle galvanisée pour éviter les dommages dus à une exposition prolongée à un environnement humide. Accessoire à demander avant la production du MULTIPLO.

 Stützsockel aus verzinktem Blech zum Schutz vor Schäden durch längere Einwirkung einer feuchten Umgebung. Zubehör vor der Produktion des MULTIPLO anzufordern.

 Base de apoyo en chapa galvanizada para evitar daños por exposición prolongada a un ambiente húmedo. Accesorio a solicitar antes de la producción del MULTIPLO.

CODE	dimensions
<b>MULTIPLO-GB</b>	1 X BIG LEG, 1 X SMALL LEG

# MULTIPLO-XB

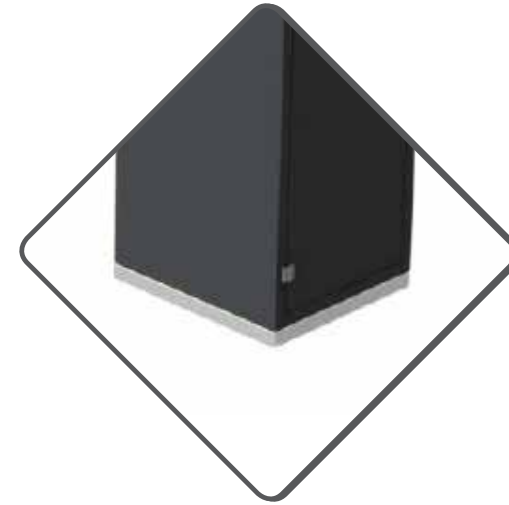

 Base d'appoggio in INOX per evitare i danni da esposizione prolungata ad un ambiente in pavimento presenza d'acqua. Accessorio da richiedere prima della produzione del MULTIPLO.

 Stainless steel support base to prevent damage from prolonged exposure to a floor environment with water presence. Accessory to be requested before MULTIPLO production.

 Socle en acier inoxydable pour éviter les dommages dus à une exposition prolongée dans un environnement au sol avec présence d'eau. Accessoire à demander avant la production du MULTIPLO.

 Stützsockel aus Edelstahl zum Schutz vor Schäden durch längere Einwirkung einer Bodenumgebung mit Wasser. Zubehör vor der Produktion des MULTIPLO anzufordern.

 Base de apoyo en acero inoxidable para evitar daños por exposición prolongada en un entorno de suelo con presencia de agua. Accesorio a solicitar antes de la producción del MULTIPLO.

CODE	dimensions
<b>MULTIPLO-XB</b>	1 X BIG LEG, 1 X SMALL LEG

# MULTIPLLO-XL



 Se il multiplo non è abbastanza grande per le tue esigenze, ecco che entra in gioco il MULTIPLLO-XL. Sviluppato da WORKY per alloggiare fino a 16 arrotolatori per la distribuzione dei fluidi e fino a 2 arrotolatori per l'aspirazione dei gas di scarico. Su richiesta è possibile allestire il portale con banchi di lavoro attrezzati e contenitivi. Quando il gioco si fa duro, MULTIPLLO diventa XL: grande spazio, grande struttura per grandi officine.

 If the MULTIPLLO is not enough for your needs, the MULTIPLLO-XL comes into play. Designed by WORKY for large workshops, this portal can accommodate up to 16 hose reels for fluid distribution and up to 2 hose reels for exhaust gas extraction. On request, the MULTIPLLO-XL can also be equipped with fitted and storage workbenches, turning it into a complete multifunctional station.

When maximum space and strength are required, MULTIPLLO becomes XL: the ideal solution for large workshops.

 Si le MULTIPL0 ne suffit pas à vos besoins, le MULTIPL0-XL prend le relais.

Conçu par WORKY pour les grands ateliers, ce portique peut accueillir jusqu'à 16 enrouleurs pour la distribution des fluides et jusqu'à 2 enrouleurs pour l'aspiration des gaz d'échappement. Sur demande, le MULTIPL0-XL peut être équipé de postes de travail aménagés et de rangement, devenant ainsi une véritable station multifonction.

Quand l'espace et la robustesse deviennent essentiels, le MULTIPL0 devient XL: la solution idéale pour les grands ateliers.

 Wenn der MULTIPL0 für Ihre Anforderungen nicht ausreicht, kommt der MULTIPL0-XL ins Spiel. Von WORKY für große Werkstätten entwickelt, bietet dieser Portalkörper Platz für bis zu 16 Schlauchaufroller für die Fluidverteilung und bis zu 2 Schlauchaufroller für die Abgasabsaugung. Auf Wunsch kann der MULTIPL0-XL mit ausgestatteten und aufbewahrenden Werkbänken konfiguriert werden und wird so zu einer echten Multifunktionsstation. Wenn maximaler Raum und Stabilität gefordert sind, wird MULTIPL0 zu XL: die ideale Lösung für große Werkstätten.

 Si el MULTIPL0 no es suficiente para tus necesidades, entra en juego el MULTIPL0-XL. Diseñado por WORKY para talleres de gran tamaño, este pórtico puede alojar hasta 16 enrolladores para la distribución de fluidos y hasta 2 enrolladores para la aspiración de gases de escape. Bajo pedido, el MULTIPL0-XL puede equiparse con bancos de trabajo equipados y de almacenamiento, convirtiéndose en una auténtica estación multifunción. Cuando se requiere el máximo espacio y robustez, MULTIPL0 se convierte en XL: la solución ideal para los grandes talleres.



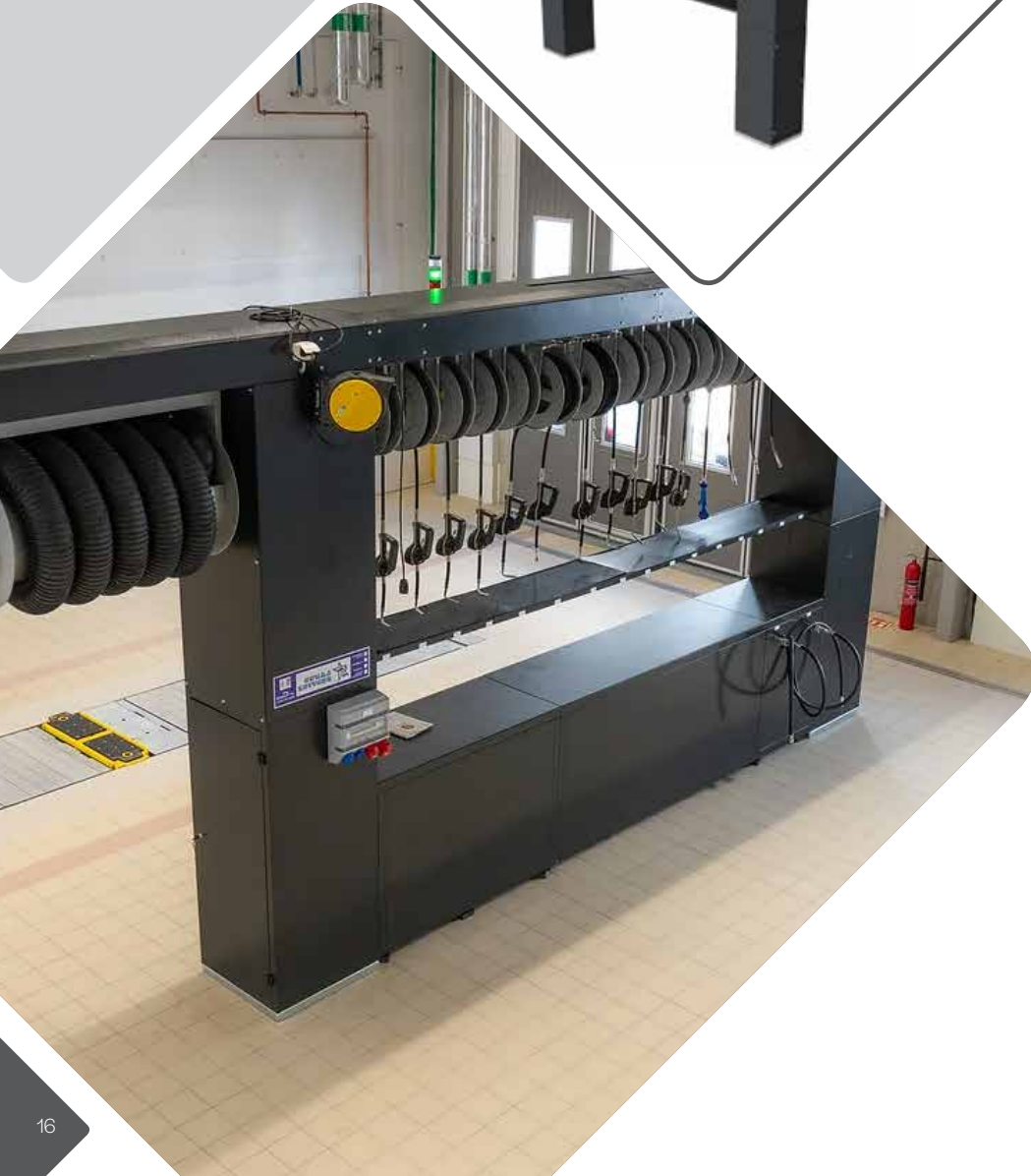

# MULTIPLLO-XL



 Portale EXTRA LARGE per la distribuzione di fluidi ed energie con supporto di 1 arrotolatore per gas di scarico. Può alloggiare fino ad 16 avvolgitori da 15 mt per distribuzione fluidi. Attrezzabile con banco di lavoro a richiesta.

 EXTRA LARGE portal for fluid and energy distribution with support for 2 exhaust gas reels. Can accommodate up to 16 reels of 15 m for fluid distribution. Workbench can be fitted on request.

 Portail EXTRA LARGE pour la distribution de fluides et d'énergies avec support pour 1 enrouleur de gaz d'échappement. Peut accueillir jusqu'à 16 enrouleurs de 15 m pour la distribution de fluides. Poste de travail disponible sur demande.

 EXTRA LARGE Portal für die Verteilung von Flüssigkeiten und Energie mit Halterung für 1 Abgasaufroller. Kann bis zu 16 Aufroller à 15 m für die Flüssigkeitsverteilung aufnehmen. Werkbank auf Anfrage nachrüstbar.

 Portal EXTRA LARGE para la distribución de fluidos y energía con soporte para 1 enrollador de gases de escape. Puede alojar hasta 16 enrolladores de 15 m para la distribución de fluidos. Banco de trabajo disponible bajo pedido.

CODE	MAX NR. REELS	GB	DIM.
<b>MULTIPLLO-XL</b>	16 WORKY REELS x 1/2" -15 mt	-	7,2 x 0,66 x H 3,55 m
<b>MULTIPLLO-UXL</b>	16 UNIVERSAL REELS x 1/2" -15 mt	-	
<b>MULTIPLLO-XL-GB</b>	16 WORKY REELS x 1/2" -15 mt	✓	
<b>MULTIPLLO-UXL-GB</b>	16 UNIVERSAL REELS x 1/2" -15 mt	✓	





# MULTIPLLO-2GXL



 Portale EXTRA LARGE per la distribuzione di fluidi ed energie con supporto di 2 arrotolatori per gas di scarico. Può alloggiare fino ad 16 avvolgitori da 15 mt per distribuzione fluidi. Attrezzabile con banco di lavoro a richiesta.

 EXTRA LARGE portal for fluid and energy distribution with support for 2 exhaust gas reels. Can accommodate up to 16 reels of 15 m for fluid distribution. Workbench can be fitted on request.

 Portique EXTRA LARGE pour la distribution de fluides et d'énergies avec support pour 2 enrouleurs de gaz d'échappement. Peut accueillir jusqu'à 16 enrouleurs de 15 m pour la distribution de fluides. Poste de travail disponible sur demande.

 EXTRA LARGE Portal für die Verteilung von Flüssigkeiten und Energie mit Halterung für 2 Abgasaufroller. Kann bis zu 16 Aufroller à 15 m für die Flüssigkeitsverteilung aufnehmen. Werkbank auf Anfrage nachrüstbar.

 Portal EXTRA LARGE para la distribución de fluidos y energía con soporte para 2 enrolladores de gases de escape. Puede alojar hasta 16 enrolladores de 15 m para la distribución de fluidos. Banco de trabajo disponible bajo pedido.

CODE	MAX NR. REELS	GB	DIM.
<b>MULTIPLLO-2GXL</b>	16 WORKY REELS x 1/2" -15 mt	-	8,7 x 0,66 x H 3,55 m
<b>MULTIPLLO-2GUXL</b>	16 UNIVERSAL REELS x 1/2" -15 mt	-	
<b>MULTIPLLO-2GXL-GB</b>	16 WORKY REELS x 1/2" -15 mt	√	
<b>MULTIPLLO-2GUXL-GB</b>	16 UNIVERSAL REELS x 1/2" -15 mt	√	



via Masaccio, 15  
 42124 Reggio Emilia (RE) ITALY  
 Tel. +39 0522 1545193  
 vendite@worky-italy.com  
 sales@worky-italy.com

www.worky-italy.com

MULTIPLO-2GUXL-GB - technical datasheet

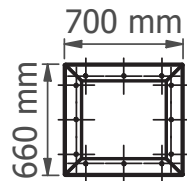
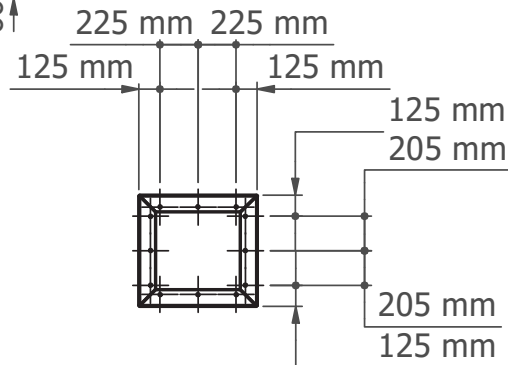
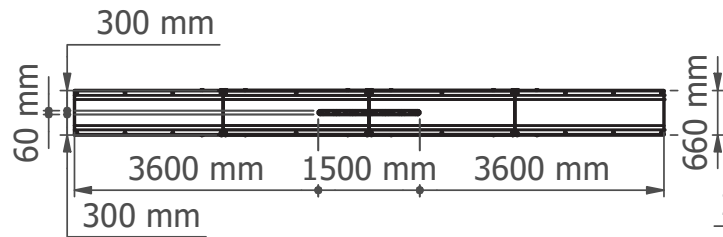
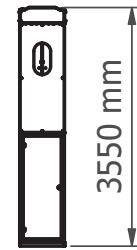
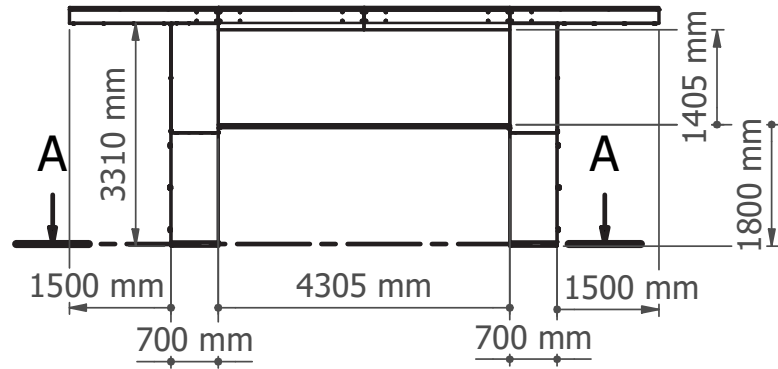



A-A

# MONOPOST



 Struttura a singolo pilastro per sostenere 1 o 2 arrotolatori per l'aspirazione dei gas di scarico e 2 batterie laterali da 8 avvolgitori ciascuna per la distribuzione di olio e fluidi tecnici. data la sua struttura singola e l'enorme peso che riesce a sorreggere, il prodotto MONOPOST deve essere cementato a terra con la sua apposita flangia dotata di zanche metalliche di fissaggio. Una porta di ispezione permette di accedere all'interno per posizionarvi un distributore di grasso o per la pompa di recupero dell'olio esausto. Minima impronta a terra, ma grande capacità di asservimento della zona di lavoro.

 Single-pillar structure to support 1 or 2 hose reels for vehicle exhaust extraction and two side batteries, each with 8 hose reels for dispensing oil and technical fluids. Given its single-column design and the high load it can bear, the MONOPOST must be anchored in concrete using its dedicated base flange with steel fixing anchors. An inspection door provides access inside to install a grease dispenser or a used-oil recovery pump. Minimal floor footprint, yet high servicing capacity for the work area.

 Structure à pilier unique permettant de soutenir 1 ou 2 enrouleurs pour l'aspiration des gaz d'échappement et deux batteries latérales de 8 enrouleurs chacune pour la distribution d'huile et de fluides techniques. En raison de sa conception monocolonne et de la charge élevée supportée, le MONOPOST doit être scellé dans le béton au moyen de sa bride de base dédiée, équipée de tiges d'ancrage en acier. Une porte d'inspection permet d'accéder à l'intérieur pour y installer un distributeur de graisse ou une pompe de récupération d'huile usagée. Empreinte au sol minimale, grande capacité d'asservissement de la zone de travail.

 Einzelpfeiler-Konstruktion zur Aufnahme von 1 oder 2 Schlauchaufrollern für die Abgasabsaugung sowie zwei seitlichen Batterien mit jeweils 8 Aufrollern für die Ausgabe von Öl und technischen Fluiden. Aufgrund der einständigen Bauweise und der hohen Tragfähigkeit muss der MONOPOST mit seiner speziellen Bodenflanschplatte und Stahllankerbolzen im Beton verankert werden. Eine Inspektionstür ermöglicht den Zugang zum Inneren, um dort einen Fettdosierer oder eine Altöl-Rückförderpumpe zu installieren. Geringe Stellfläche, aber hohe Versorgungskapazität im Arbeitsbereich.

 Estructura de pilar único para sostener 1 o 2 enrolladores para la aspiración de gases de escape y dos baterías laterales con 8 enrolladores cada una para la distribución de aceite y fluidos técnicos. Debido a su diseño de columna única y a la alta carga que puede soportar, el MONOPOST debe anclarse en hormigón mediante su brida de base específica equipada con anclajes de fijación de acero. Una puerta de inspección permite acceder al interior para colocar un dispensador de grasa o una bomba de recuperación de aceite usado. Huella en el suelo mínima, pero gran capacidad de servicio del área de trabajo.

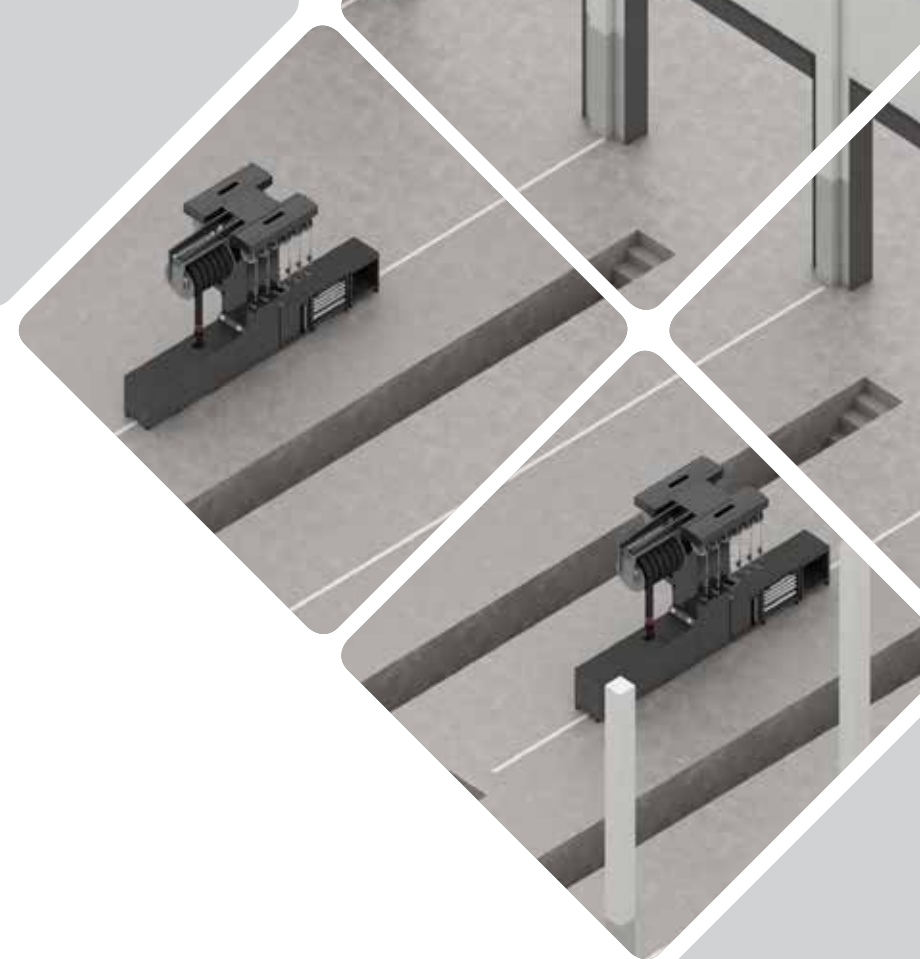



# MONOPOST-1



 Struttura a pilastro per la distribuzione di fluidi ed energie con supporto arrotolatore per gas di scarico. Può alloggiare fino ad 16 avvolgitori fino a 15 mt: attrezzabile con banco di lavoro a richiesta.

 Fluid and energy distribution Post with support for exhaust extraction hose reel. It can welcome up to 16 reels for fluids 15 mt long. Prepared for cabinets on demand.

 Poteau pour la distribution des fluides et énergies, avec support pour l'enrouleur pour gaz d'échappement. Possibilité d'installer jusqu'à 16 enrouleurs de 15m. Prévu pour établi de travail.

 Standsäule für Flüssigkeit, Energieversorgung, und einen Schlauchaufroller für Abgas. Es kann bis 16 Schlauchaufroller 15m lang ausgestattet werden. Werkbank auf Wunsch.

 Estructura para la distribución de fluidos, energías y soporte para enrollador de aspiración gas de escape. Está preparado para max. 16 enrolladores de 15 m. Banco de trabajo bajo petición.

CODE	MAX NR. REELS	GAS	DIM. MAX
<b>MONOPOST-1</b>	16 WORKY REELS x 1/2" -15 mt	1	3,85 x 1,76 x
<b>MONOPOST-2</b>	16 UNIVERSAL REELS x 1/2" -15 mt	2	H 3,51 m



via Masaccio, 15  
 42124 Reggio Emilia (RE) ITALY  
 Tel. +39 0522 1545193  
 vendite@worky-italy.com  
 sales@worky-italy.com

www.worky-italy.com

# MONOPOST-1 - technical datasheet

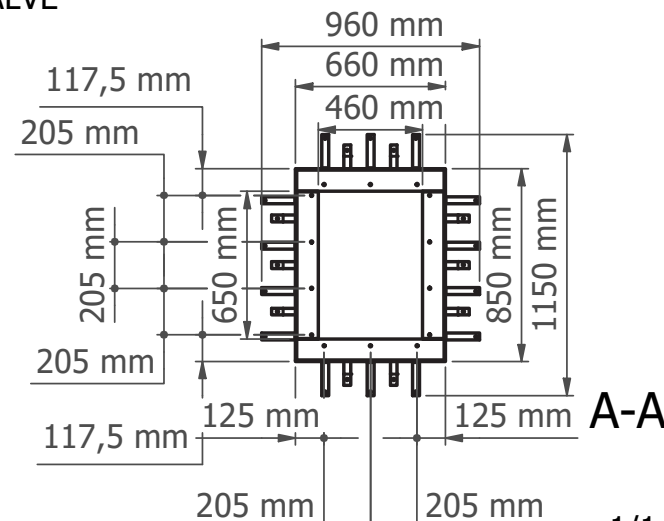
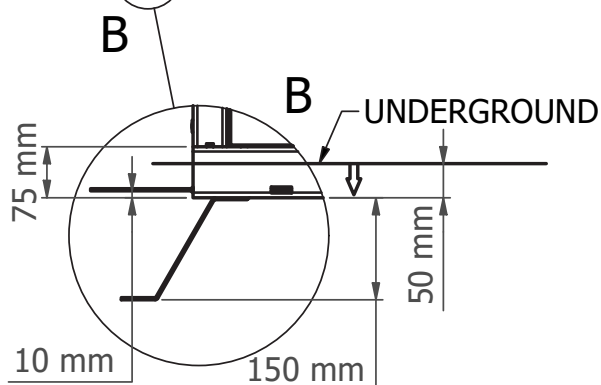
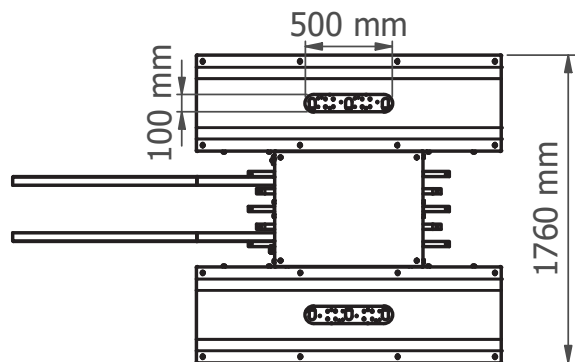
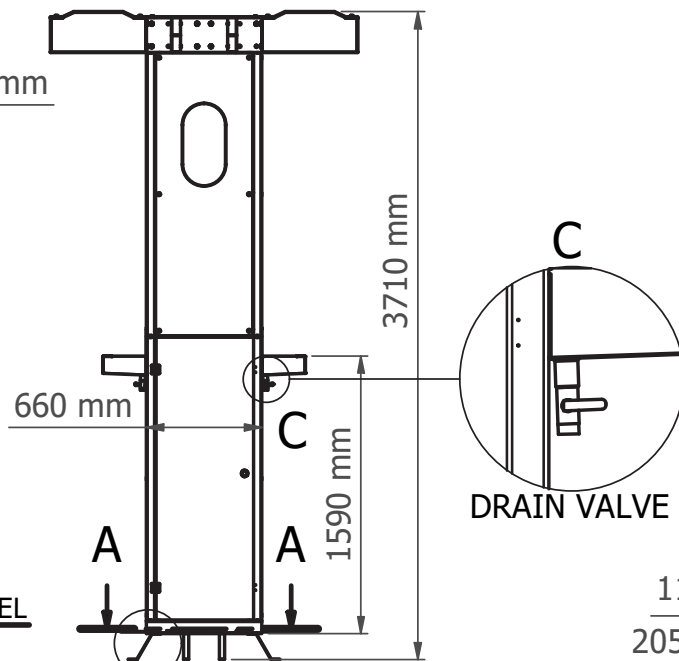
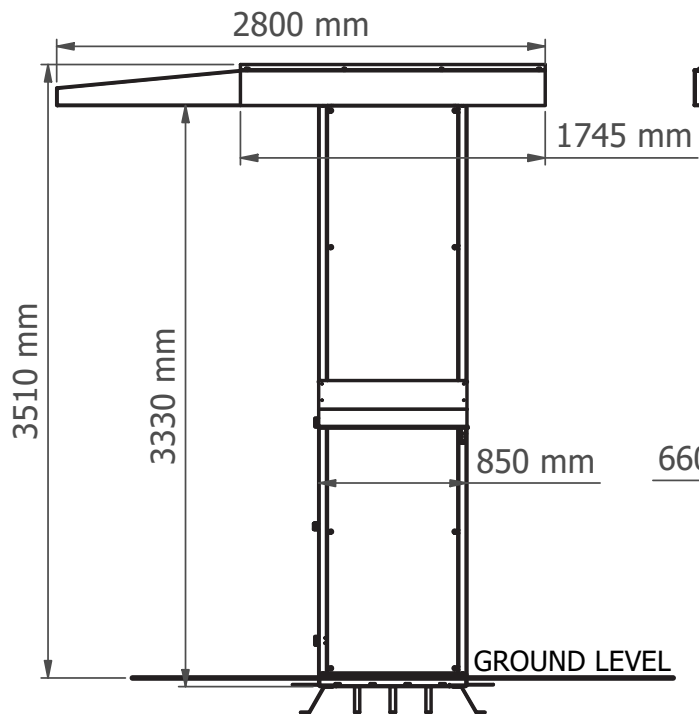

THIS DRAWING IS PROPERTY OF DEA + RO & Co S.p.A. THE COMPLETE OR PARTIAL REPRODUCTION OF THIS DOCUMENT IS FORBIDDEN. THE OWNER RESERVES THE RIGHT TO UPDATE, MODIFY OR AMEND ANY SPECIFICATION WITHOUT PRIOR NOTICE.

Rev.00

1/1  
 19/05/2022

# MONOPOST-L



 Struttura a pilastro a sviluppo longitudinale per la distribuzione di fluidi ed energie con supporti utili sia per arrotolatori di aspirazione gas di scarico che per avvolgitori fluidi disposti in linea con il passaggio dei mezzi.

 Pillar structure with longitudinal development for the distribution of fluids and energy, equipped with supports suitable both for exhaust extraction hose reels and for fluid dispensers arranged in line with vehicle passage.

 Structure à pilier à développement longitudinal pour la distribution de fluides et d'énergies, équipée de supports adaptés aussi bien aux enrouleurs d'aspiration des gaz d'échappement qu'aux enrouleurs de fluides disposés dans l'alignement du passage des véhicules.

 Pfeilerkonstruktion mit längsgerichteter Ausführung für die Verteilung von Fluiden und Energien, ausgestattet mit Halterungen sowohl für Abgasabsaug-Schlauchaufroller als auch für Fluidaufroller, die in Linie mit der Fahrzeugdurchfahrt angeordnet sind.

 Estructura de pilar con desarrollo longitudinal para la distribución de fluidos y energías, equipada con soportes aptos tanto para enrolladores de aspiración de gases de escape como para enrolladores de fluidos dispuestos en línea con el paso de los vehículos.

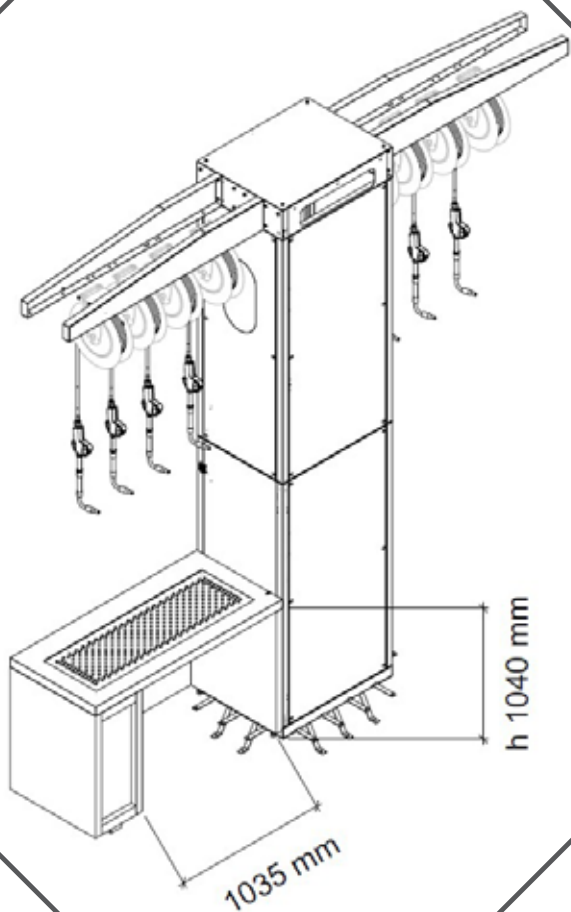

CODE	MAX NR. REELS	GAS	DIM.
<b>MONOPOST-L</b>	MAX 12 x 1/2" -15 mt	MAX 2	3,85 x 1,16 x
<b>MONOPOST-L/SFR</b>	MAX 12 x 1/2" -15 mt	MAX 2	H 3,48 m



via Masaccio, 15  
 42124 Reggio Emilia (RE) ITALY  
 Tel. +39 0522 1545193  
 vendite@worky-italy.com  
 sales@worky-italy.com

www.worky-italy.com

# MONOPOST-L - technical datasheet

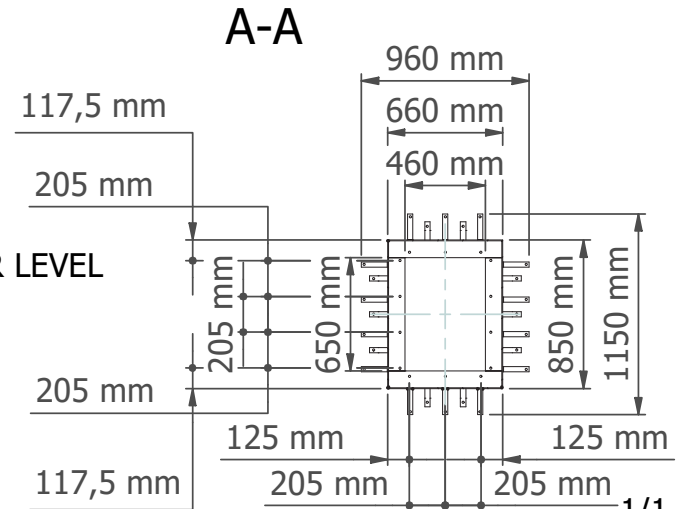
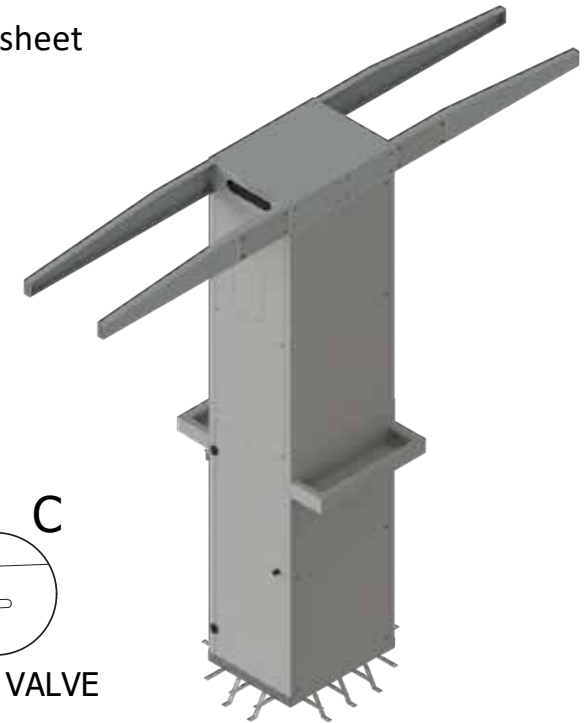
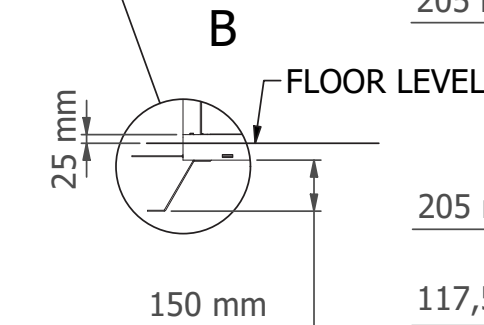
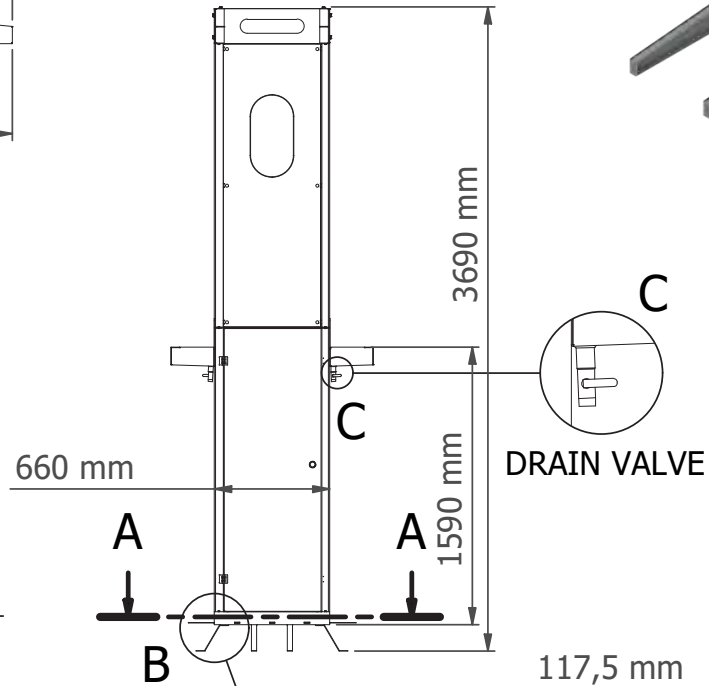
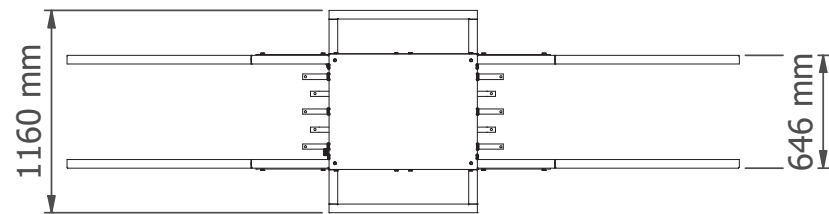
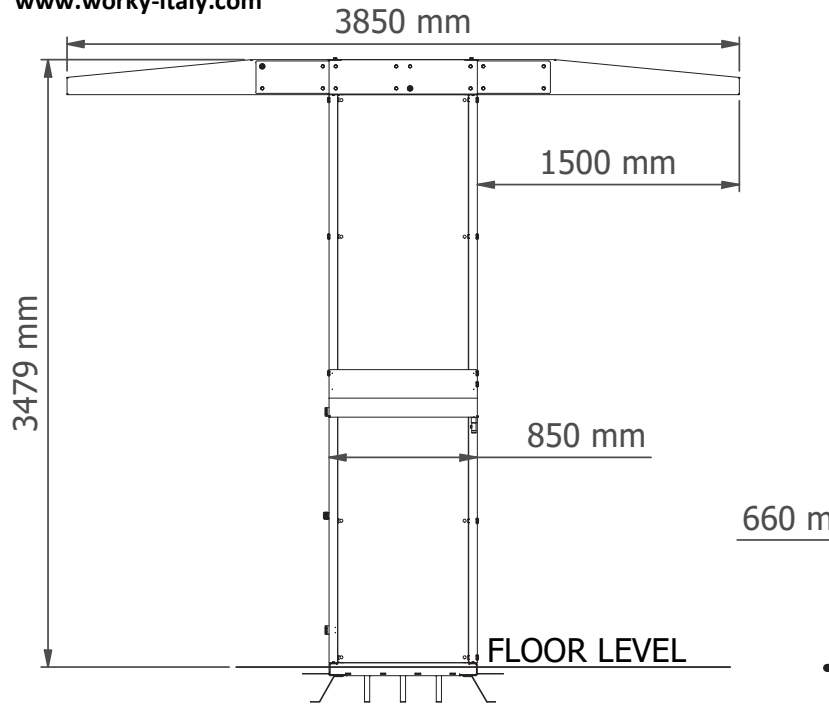



# FRMF



 Il portale FRMF è stato concepito per distribuire fluidi in officine auto e camion, sia in alloggiamento a parete o al centro dell'officina. Le configurazioni possibili sono per 4 o 6 arrotolatori, sia in versione semplice che carenata con pannellature e antine nella parte sottostante. Pulito, robusto e studiato appositamente allo scopo, FRMF rimane la pietra miliare per raggiungere le postazioni di lavoro con i sistemi di distribuzione puntuale dei fluidi. Il prodotto viene assemblato a destinazione per ridurre al minimo i costi di trasporto e le spalle di supporto fungono da passaggio di cavi e tubi per collegare i vari prodotti alloggiati nelle due sezioni del portale.

 The FRMF tower has been designed to distribute fluids in car and truck workshops and can be positioned both along the walls or in the workshop center. The possible configurations are for 4 or 6 reels, both in the simple version and with the panels and cabinets in the lower part. Clean, robust and designed specifically for this purpose, FRMF remains the milestone to reach work stations with punctual fluid distribution systems. The product is assembled on site to minimize transport costs and the supporting columns act as tunnel for cables and pipes to connect the various products housed in the two sections of the portal.

 Le portique FRMF a été conçu pour distribuer les fluides dans les ateliers de réparation voitures et camions, soit dans le boîtier mural, soit dans le centre de l'atelier. Les configurations possibles sont pour 4 ou 6 enrouleurs, à la fois dans la version simple et avec les panneaux et les armoires dans la partie inférieure. Propre, robuste et conçu spécifiquement à cet effet, le FRMF reste la référence pour atteindre les postes de travail avec des systèmes de distribution de fluide ponctuels. Le produit est assemblé à destination pour minimiser les coûts de transport et les épaulements de support servent de câbles et de tuyaux pour relier les différents produits logés dans les deux sections du portique.

 Das FRMF-Portal wurde entwickelt, um Flüssigkeiten in Auto- und LKW-Werkstätten entweder an den Wänden entlang oder in der Werkstattzentrum zu verteilen. Die möglichen Konfigurationen sind für 4 oder 6 Aufrollen, sowohl in der einfachen Version als auch mit den Paneelen und Schrank im unteren Teil. Sauber, robust und speziell für diesen Zweck entwickelt, bleibt FRMF der Grundstein, um die Arbeitsplätze mit pünktlichen Flüssigkeitsverteilungssystemen zu erreichen. Das Produkt wird am Bestimmungsort zusammengebaut, um die Transportkosten zu minimieren. Die Stütz Säulen wirken als Passage für Kabel und Rohre, um die verschiedenen Produkte zu verbinden, die in den zwei Abschnitten des Portals eingebaut sind.

 El pórtico FRMF fue diseñado para distribuir fluidos en talleres de automóviles y camiones y es adaptado sea para posicionamiento a pared o en el centro del taller. Las configuraciones posibles son para 4 o 6 carretes, tanto en la versión simple como con paneles y puertas en la parte inferior. Limpio, robusto y diseñado específicamente para este propósito, FRMF sigue siendo la referencia técnica para llegar a las estaciones de trabajo con sistemas puntuales de distribución de fluidos. Para minimizar el transporte, el producto se ensambla en destino y los soportes laterales conectan los diversos productos alojados en las dos secciones del portal.





# FRMF-4

 Portale aperto predisposto per alloggiare fino a 4 arrotolatori nella parte superiore della struttura. Vasca raccogliogocce inclusa anche nella parte bassa del portale.

 Open gantry designed to accommodate up to 4 reels in the upper part of the structure. Drip tray also included in the lower part.

 Portique ouvert conçu pour accueillir jusqu'à 4 enrouleurs dans la partie supérieure de la structure. Bac à égouttement également inclus dans la partie inférieure.

 Offene Portal vorbereitet für bis zu 4 Schlauchaufrollern im oberen Teil der Struktur. Tropfwanne auch im unteren Teil des Portals enthalten.

 Pórtico abierto diseñado para acomodar hasta 4 enrolladores en la parte superior de la estructura. Bandeja de goteo también incluida en la parte inferior.

CODE	DIMENSIONS.	MAX NR. REELS	RAL
<b>FRMF-4</b>	1080 X 500 X H 2350 mm	4 (1/2" - 15 m)	7016



**WORKY**

A brand of RO & CO S.p.A  
via G. di Vittorio, 1  
42025 Cavriago (RE) ITALY  
Tel. +39 0522 1545193  
Fax +39 0522 1546451  
vendite@worky-italy.com  
sales@worky-italy.com  
www.worky-italy.com

# FRMF4

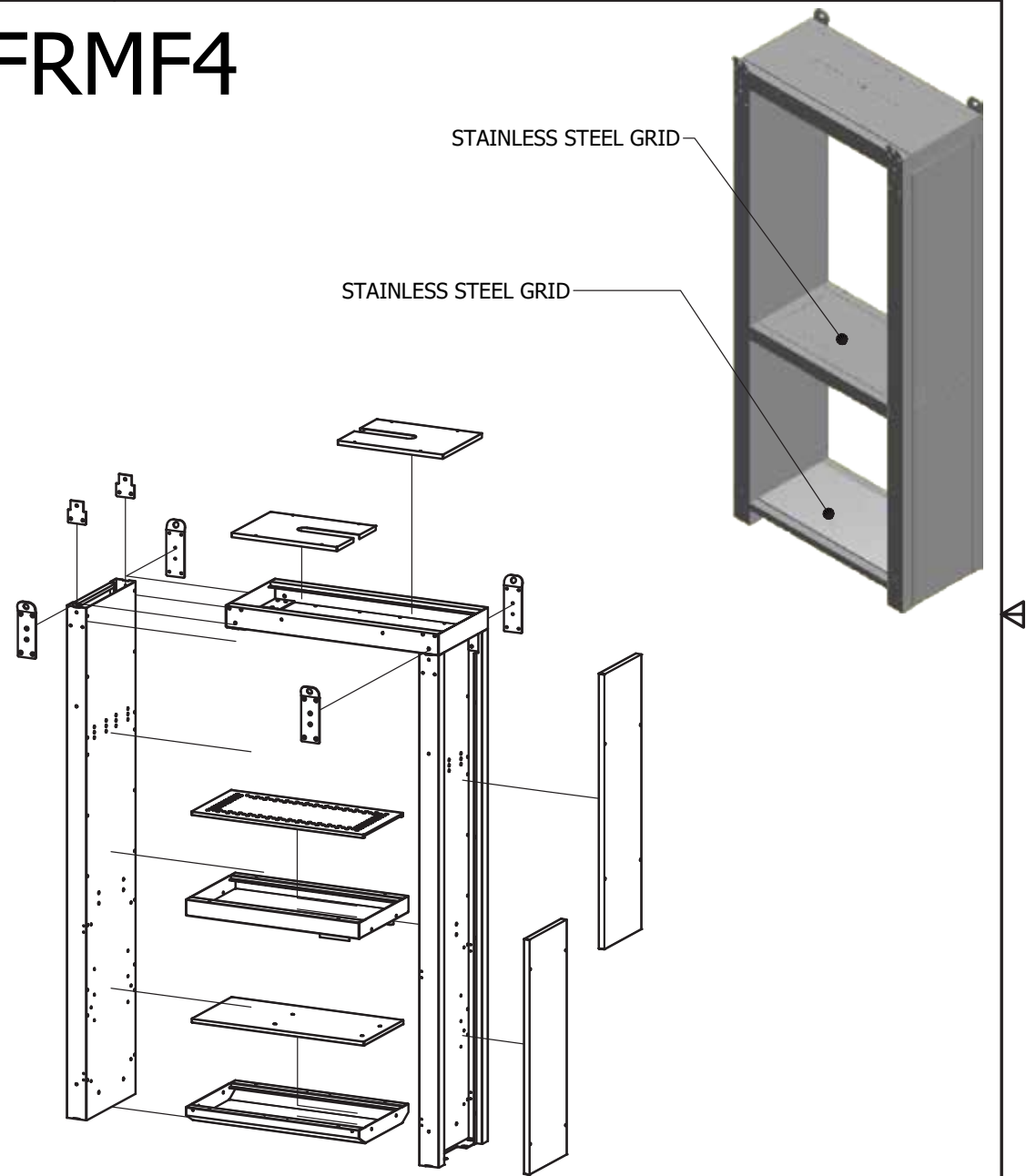
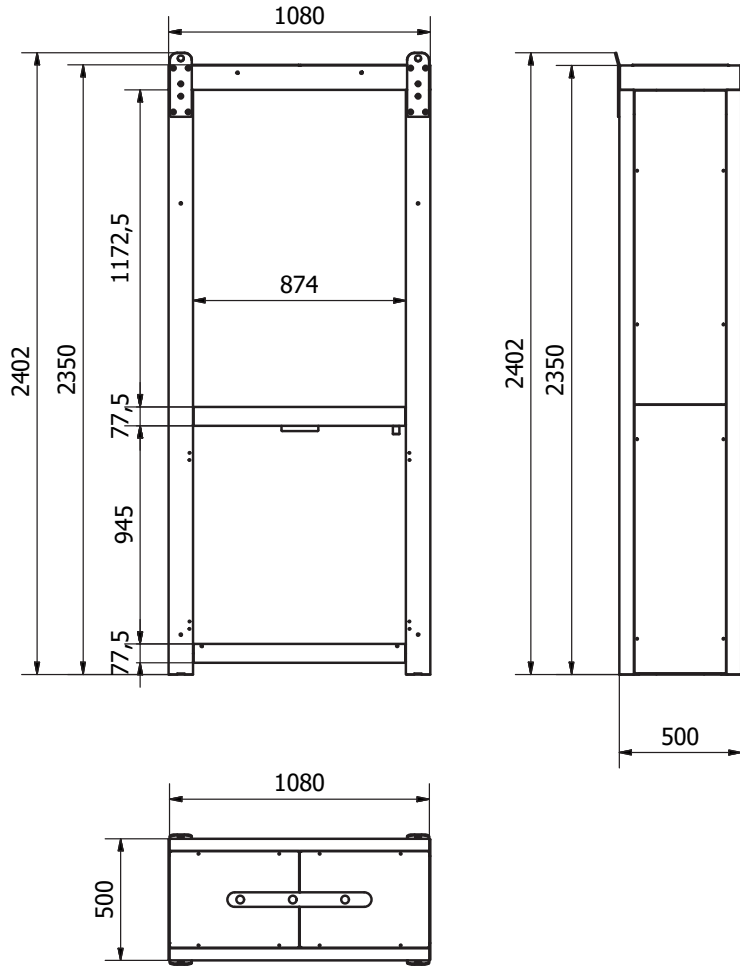

E' VIETATA LA RIPRODUZIONE TOTALE E/O PARZIALE DEL PRESENTE DISEGNO CHE E' DI PROPRIETA' DI RO & CO SPA P102492210352  
RO & CO SPA SI RISERVA LA FACOLTA' DI AGGIORNARE E O MODIFICARE TUTTO O IN PARTE LE PRESENTI SPECIFICHE SENZA PREAVVISO.

Rev.

21/12/2017

# FRMF-4C



 Portale carenato con alloggiamento fino a 4 arrotolatori nella parte superiore della struttura. Porte a battente nella parte bassa e vasca raccogli gocce inclusa.

 Enclosed gantry designed to accommodate up to 4 reels in the upper part of the structure. Double door and drip tray also included in the lower part.

 Portique à panneaux avec logement pour accueillir jusqu'à 4 enrouleurs dans la partie supérieure de la structure. Porte double dans la partie inférieure et bac d'égouttage inclus.

 Geschlossene Portal vorbereitet für bis zu 4 Aufrollen im oberen Teil des Gebäudes. Unterer Schrank mit Doppeltüren und Tropfwanne enthalten.

 Pórtico con paneles con alojamiento para hasta 4 enrolladores en la parte superior de la estructura. Puerta doble en la parte inferior y bandeja de goteo incluida.

CODE	DIMENSIONS.	MAX NR. REELS	RAL
<b>FRMF-4C/7016</b>	1080 X 500 X H 2350 mm	4 (1/2" - 15 m)	7016
<b>FRMF-4C/7021</b>	1080 X 500 X H 2350 mm	4 (1/2" - 15 m)	7021
<b>FRMF-4C/7040</b>	1080 X 500 X H 2350 mm	4 (1/2" - 15 m)	7040
<b>FRMF-4C/9005</b>	1080 X 500 X H 2350 mm	4 (1/2" - 15 m)	9005

# WORKY

A brand of RO&Co. S.p.A.  
via Masaccio 15 - Z.I. Mancasale  
42124 REGGIO EMILIA - Italy  
Tel. +39 0522 1545193  
Fax +39 0522 1546451  
vendite@worky-italy.com  
sales@worky-italy.com  
www.worky-italy.com

## FRMF4C/7016

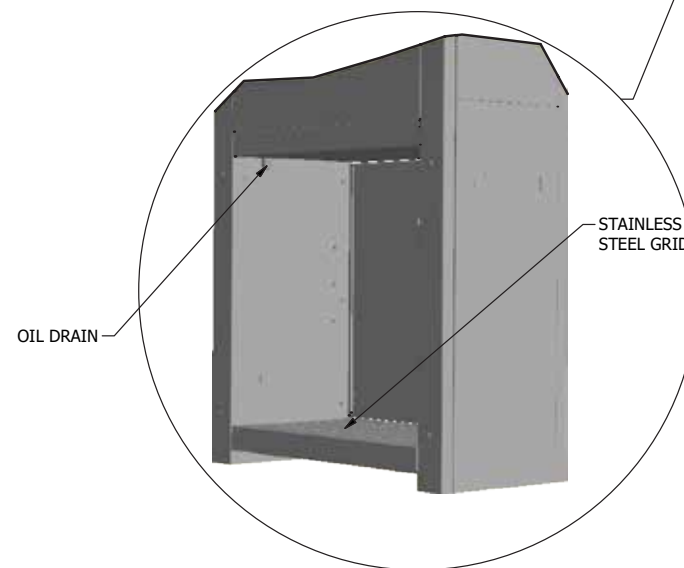
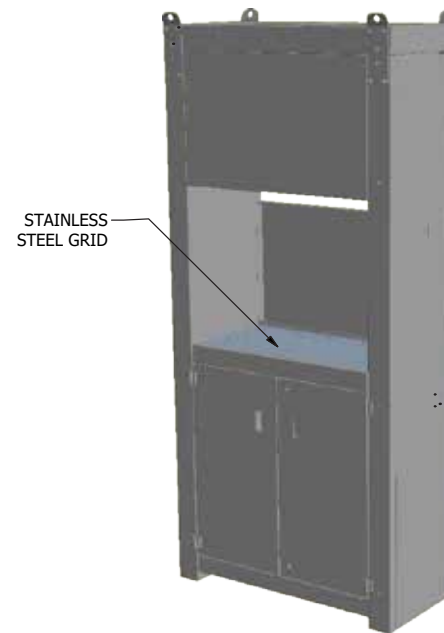
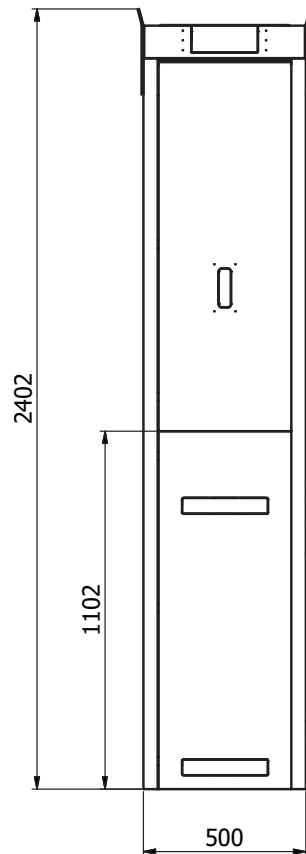
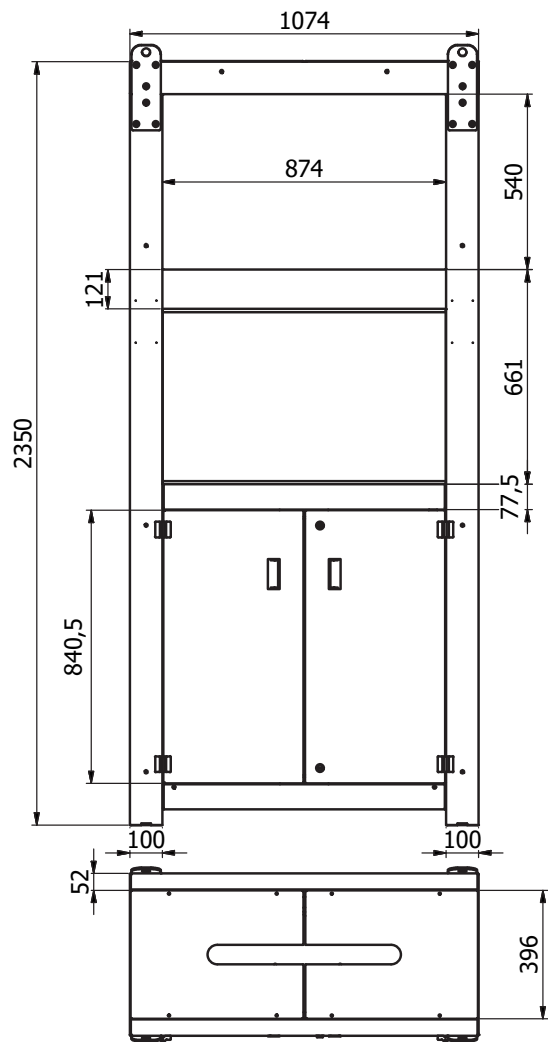



E' VIETATA LA RIPRODUZIONE TOTALE E/O PARZIALE DEL PRESENTE DISEGNO CHE E' DI PROPRIETA' DI RO & CO SPA PI02492210352  
RO & CO SPA SI RISERVA LA FACOLTA' DI AGGIORNARE E O MODIFICARE TUTTO O IN PARTE LE PRESENTI SPECIFICHE SENZA PREAVVISO.

Rev.

04/04/2018

# FRMF-6

 Portale aperto predisposto per alloggiare fino a 6 arrotolatori nella parte superiore della struttura. Vasca raccogliocce inclusa anche nella parte bassa del portale.

 Open gantry designed to accommodate up to 6 reels in the upper part of the structure. Drip tray also included in the lower part.

 Portique ouvert conçu pour accueillir jusqu'à 6 enrouleurs dans la partie supérieure de la structure. Bac à égouttement également inclus dans la partie inférieure.

 Offene Portal vorbereitet für bis zu 6 Schlauchaufrollern im oberen Teil der Struktur. Tropfwanne auch im unteren Teil des Portals enthalten.

 Pórtico abierto diseñado para acomodar hasta 6 enrolladores en la parte superior de la estructura. Bandeja de goteo también incluida en la parte inferior.

CODE	DIMENSIONS.	MAX NR. REELS	RAL
<b>FRMF-6</b>	1440 X 500 X H 2350 mm	6 (1/2" - 15 m)	7016





A brand of RO & CO S.p.A  
via G. di Vittorio, 1  
42025 Cavriago (RE) ITALY  
Tel. +39 0522 1545193  
Fax +39 0522 1546451  
vendite@worky-italy.com  
sales@worky-italy.com  
www.worky-italy.com

# FRMF6

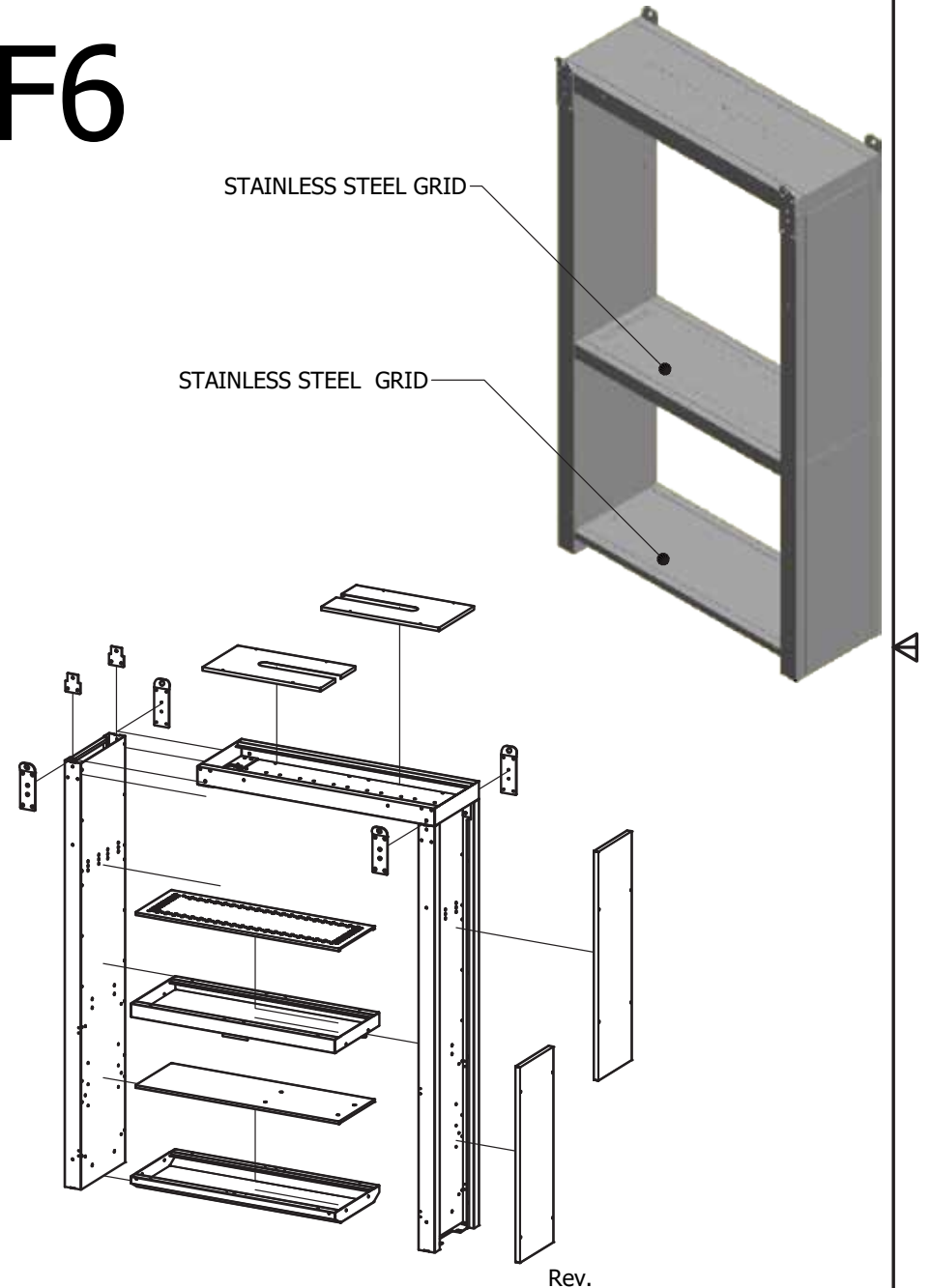
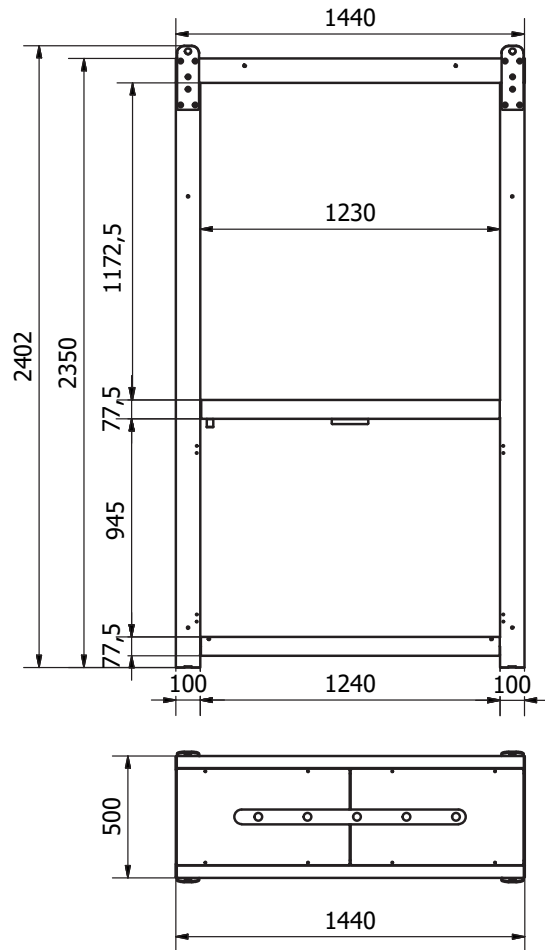



E' VIETATA LA RIPRODUZIONE TOTALE E/O PARZIALE DEL PRESENTE DISEGNO CHE E' DI PROPRIETA' DI RO & CO SPA P102492210352  
RO & CO SPA SI RISERVA LA FACOLTA' DI AGGIORNARE E/O MODIFICARE TUTTO O IN PARTE LE PRESENTI SPECIFICHE SENZA PREAVVISO.

# FRMF-6C



 Portale carenato con alloggiamento fino a 6 arrotolatori nella parte superiore della struttura. Porte a battente nella parte bassa e vasca raccogliocce inclusa.

 Enclosed gantry designed to accommodate up to 6 reels in the upper part of the structure. Double door and drip tray also included in the lower part.

 Portique à panneaux avec logement pour accueillir jusqu'à 6 enrouleurs dans la partie supérieure de la structure. Porte double dans la partie inférieure et bac d'égouttage inclus.

 Geschlossene Portal vorbereitet für bis zu 6 Aufrollen im oberen Teil des Gebäudes. Unterer Schrank mit Doppeltüren und Tropfwanne enthalten.

 Pórtico con paneles con alojamiento para hasta 6 enrolladores en la parte superior de la estructura. Puerta doble en la parte inferior y bandeja de goteo incluida.

CODE	DIMENSIONS.	MAX NR. REELS	RAL
<b>FRMF-6C/7016</b>	1440 X 500 X H 2350 mm	6 (1/2" - 15 m)	7016
<b>FRMF-6C/7021</b>	1440 X 500 X H 2350 mm	6 (1/2" - 15 m)	7021
<b>FRMF-6C/7040</b>	1440 X 500 X H 2350 mm	6 (1/2" - 15 m)	7040
<b>FRMF-6C/9005</b>	1440 X 500 X H 2350 mm	6 (1/2" - 15 m)	9005

# WORKY

A brand of RO & CO S.p.A  
via G. di Vittorio, 1  
42025 Cavriago (RE) ITALY  
Tel. +39 0522 1545193  
Fax +39 0522 1546451  
vendite@worky-italy.com  
sales@worky-italy.com  
www.worky-italy.com

## FRMF6C

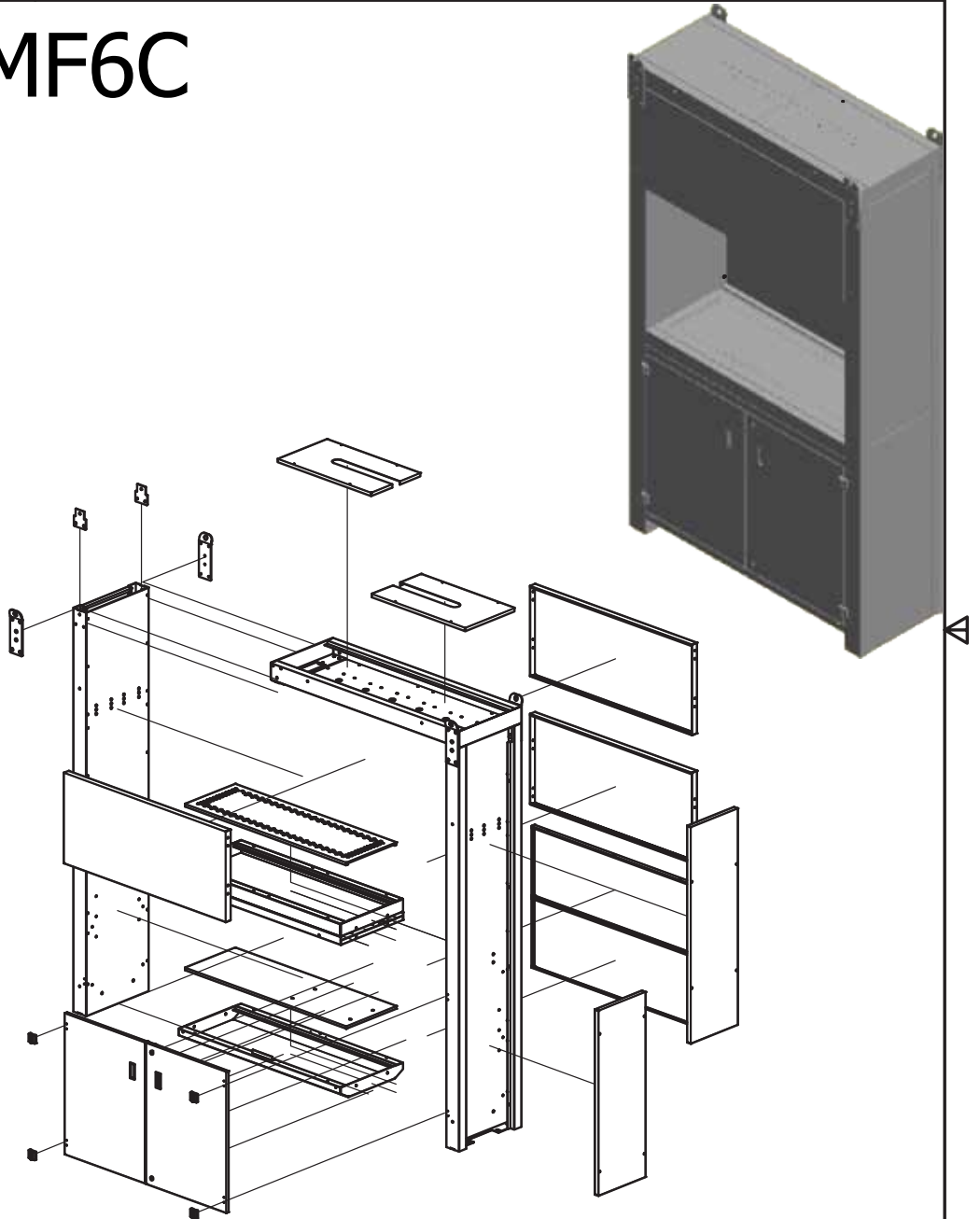
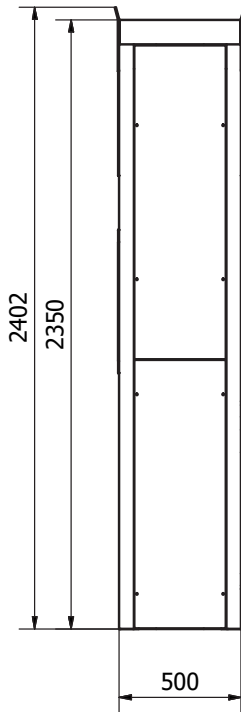
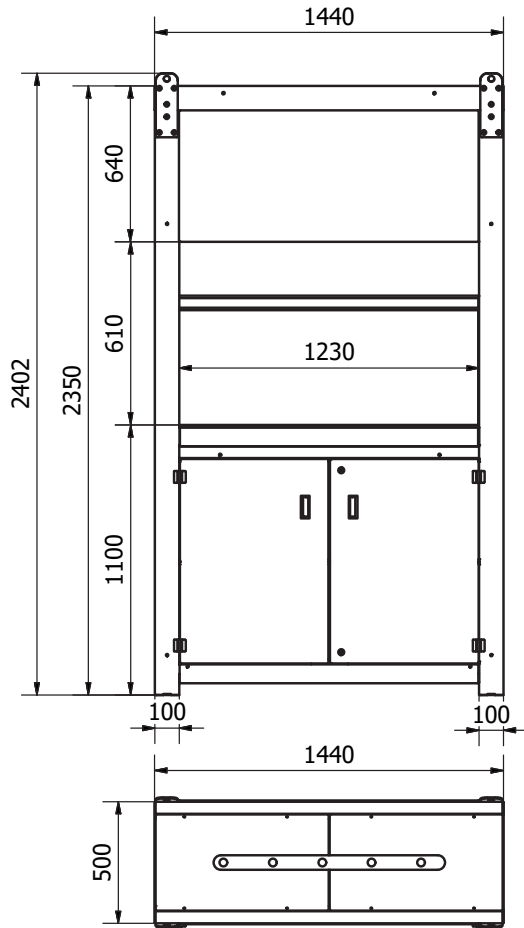

E' VIETATA LA RIPRODUZIONE TOTALE E/O PARZIALE DEL PRESENTE DISEGNO CHE E' DI PROPRIETA' DI RO & CO SPA P102492210352  
RO & CO SPA SI RISERVA LA FACOLTA' DI AGGIORNARE E O MODIFICARE TUTTO O IN PARTE LE PRESENTI SPECIFICHE SENZA PREAVVISO.

Rev.

21/12/2017

# CAT. OIL PUMP. CAT. USED OIL CAT. POWERLAB



SCAN THE QR CODE  
DOWNLOAD THE  
CATALOGUE



SCAN THE QR CODE  
DOWNLOAD THE  
CATALOGUE



SCAN THE QR CODE  
DOWNLOAD THE  
CATALOGUE



**WORRY**®

# WORKY®

## WORKY Headquarters and Production

Via Masaccio, 15 - Z.I. Mancasale  
42124 - REGGIO EMILIA (RE) ITALY

Tel. **+39-0522-1545193**

Fax. **+39-0522-1546451**

[sales@worky-italy.com](mailto:sales@worky-italy.com)

[vendite@worky-italy.com](mailto:vendite@worky-italy.com)

[www.worky-italy.com](http://www.worky-italy.com)

## WORKY North America Inc.

112 South Tryon Street  
Suite 1130 Charlotte, North Carolina  
28284 USA

Tel **+1 (305) 705 5017**

[www.deaworkyna.com](http://www.deaworkyna.com)



**Inquadra il QR Code e scopri il nostro sito!**  
**Frame the QR Code to discover our website!**



**Seguici su / Follow us on:**



QUALITY CERTIFIED ISO 9001:2015