



WORKY[®]

CENTRALINE

SERVICE UNITS

SATELLITES

ENERGIEAMPELN

CABEZALES



DTE
Pag. 4



DTE1
Pag. 6





DTEC
Pag. 8





DTE

 Le centraline multifunzione DTE sono state concepite per servire le zone di lavoro con aria compressa ed energia elettrica unitamente all'aspirazione delle polveri di carteggiatura. La grande flessibilità di utilizzo ne permette la sospensione a soffitto, il collegamento ad un braccio articolato o direttamente a parete. Le prese elettriche vengono configurate secondo le esigenze degli utensili da collegarvi e, nella parte sottostante, è presente una doppia presa d'aspirazione per poter collegare due utensili contemporaneamente.

 The DTE multifunctional service units are designed to serve the working areas with compressed air and electricity together with the extraction of dry sanding dust. The great flexibility of use allows the suspension to the ceiling, the connection to an articulated arms or directly to the walls. The electrical sockets are configured according to the needs of the tools to be connected and, in the underneath, there is an intake divided into two suction outlets to connect two tools simultaneously.

 Les unités multifonctionnelles DTE sont conçues pour desservir les zones de travail avec air comprimé et électricité en même temps que l'aspiration des poussières de ponçage. La grande souplesse d'utilisation permet la suspension du plafond, la connexion à un bras articulé ou directement au mur. Les prises électriques sont configurées en fonction des besoins des outils à raccorder. Sur le dessous, bouche divisée en deux prises d'aspiration pour relier deux outils simultanément.

 Die Multifunktionsgeräte DTE sind so konzipiert, dass sie die Arbeitsbereiche mit Druckluft und Strom zusammen mit der Absaugung von Schleifstäuben versorgen. Die große Flexibilität der Nutzung ermöglicht die Deckenabhängung, die Verbindung mit einem Gelenkarm oder direkt an der Wand. Die elektrischen Steckdosen sind entsprechend den Anforderungen der zu verbindenden Werkzeuge konfiguriert, und in der Unterseite befindet sich eine Mündung, die in zwei Saugdosen unterteilt ist, um zwei Werkzeuge gleichzeitig zu verbinden.

 Los cabezales multifuncionales DTE están diseñados para servir a las áreas de trabajo con aire comprimido y electricidad junto con la aspiración de polvos de lijado. La gran flexibilidad de uso permite la suspensión del techo, la conexión a un brazo articulado o directamente a la pared. Los enchufes eléctricos están configurados de acuerdo con los requisitos de las herramientas a conectar y, en la parte inferior, hay una boca dividida en dos tomas de extracción para conectar dos herramientas al mismo tiempo.

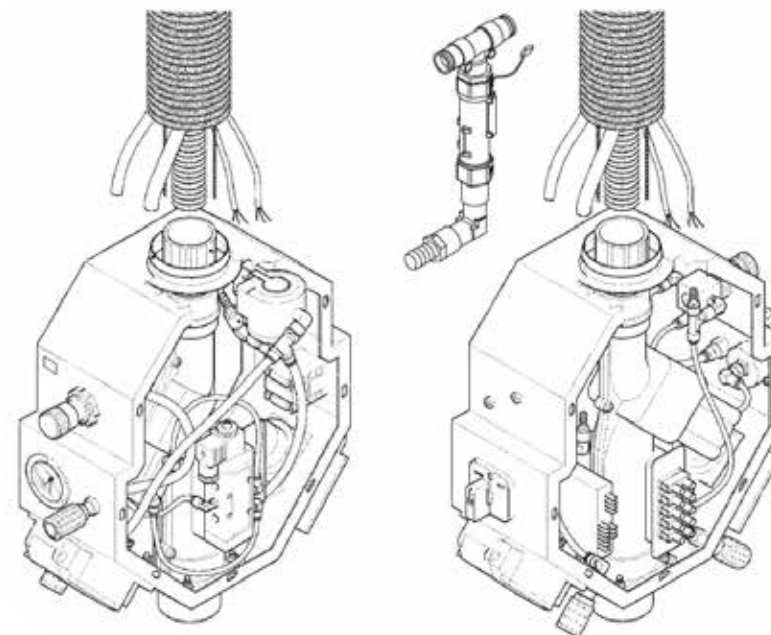



DTE



 Centralina multifunzione dotata di 2 prese elettriche, 3 attacchi aria (2 dir., 1 reg.), bocca di aspirazione polveri con deviazione a Y, maniglie di movimentazione e comando remoto per partenza turbina.

 Multifunctional service unit equipped with 2 electrical sockets, 3 compressed air intakes (2 dir., 1 reg.), Ø50 extraction inlet with Y piece DY2929 for connection up to two dry sanding machines

 Satellite multi-fonctions avec 2 prises électriques, 3 raccords d'air comprimé (2 direct réseau + 1 détendu), prise d'aspiration poussières avec déviation en "Y", poignées et interrupteur démarrage centrale d'aspiration.

 Multifunktion-Bedienungsampel, die eine komplette Verfügbarkeit von pneumatischen und elektrischen Anschlüsse, sowohl Absaugugstrichter direkt am Arbeitstelle garantiert.

 Cabezal de servicio multifunción, que garantiza completa disponibilidad de conexiones eléctricas y neumáticas, así como de tomas de extracción, directamente en la zona de trabajo.

DTE	Extr.	Pneum.	Electr.	Aut	Cut
DTEM	2 x 29 mm	3 x 3/8"	2 x 230V	-	-
DTEM-UK	2 x 29 mm	3 x 3/8"	2 x 230V	-	-
DTEA	2 x 29 mm	3 x 3/8"	2 x 230V	√	-
DTEA-UK	2 x 29 mm	3 x 3/8"	2 x 230V	√	-
DTEAC	2 x 29 mm	3 x 3/8"	2 x 230V	√	√
DTEAC-UK	2 x 29 mm	3 x 3/8"	2 x 230V	√	√



via Masaccio, 15
 42124 Reggio Emilia (RE) ITALY
 Tel. +39 0522 1545193
 vendite@worky-italy.com
 sales@worky-italy.com

www.worky-italy.com

DTE - technical datasheet

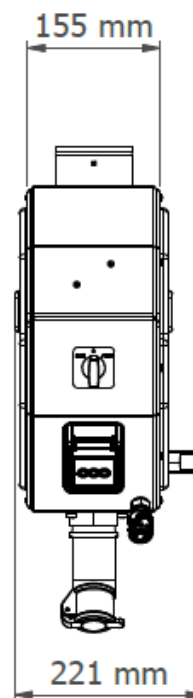
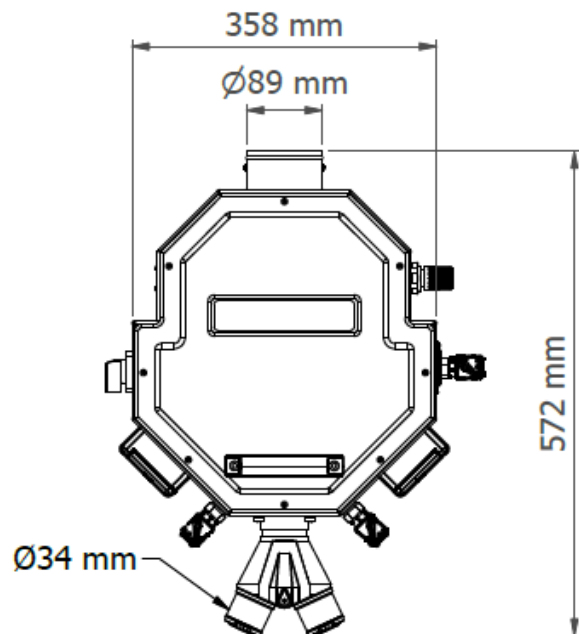

COD	El. conn.	Air. conn.	Aut	Cut	PACK			Kg Tot
					l [mm]	w [mm]	h [mm]	
DTEM	2 x 230V	3 x 3/8"	X	X	460	460	250	8
DTEA	2 x 230V	3 x 3/8"	✓	X	460	460	250	8
DTEAC	2 x 230V	3 x 3/8"	✓	✓	460	460	250	10

THIS DRAWING IS PROPERTY OF DEA + RO & Co S.p.A. THE COMPLETE OR PARTIAL REPRODUCTION OF THIS DOCUMENT IS FORBIDDEN. THE OWNER RESERVES THE RIGHT TO UPDATE, MODIFY OR AMEND ANY SPECIFICATION WITHOUT PRIOR NOTICE.

Rev.00

1/1
 08/04/2024





DTE 1





 Centralina multifunzione singola dotata di 1 presa elettrica, 1 attacco aria (reg.), 1 bocca di aspirazione polveri con tagliola manuale di chiusura e comando remoto per partenza turbina.

 Multifunctional single service unit equipped with 1 electrical socket, 1 compressed air intake (reg.), Ø29 extraction inlet with gate valve and remote start/stop of the turbine.

 Satellite simple multi-fonctions avec 1 prise électrique, 1 raccord d'air comprimé (détendu), 1 prise d'aspiration poussières avec registre manuel et interrupteur démarrage centrale d'aspiration.

 Multifunktion-Bedienungsampel, mit 1 Steckdose, 1 Druckluft Anschluß (Reguliert), 1 Absaugpunkt DN 29 mm mit Klappe und Ein / Ausschaltung der Zentralturbine.

 Cabezal multifunción singular, con 1 toma eléctrica, 1 enchufe de aire comprimido (regulado) y una toma de aspiración diam. 29 mm con cierre manual y selector de puesta en marcha de la turbina centralizada.

DTE	Extr.	Pneum.	Electr.		Aut	Cut
DTE1	1 x 29 mm	1 x 3/8"	1 x 230V		√	-
DTE1-UK	1 x 29 mm	1 x 3/8"	1 x 230V		√	-
DTE1-B	1 x 29 mm	1 x 3/8"	1 x 230V		√	-
DTE1-230	1 x 29 mm	1 x 3/8"	1 x 230V		√	-
DTE1-400	1 x 29 mm	1 x 3/8"	1 x 400V		√	-



via Masaccio, 15
42124 Reggio Emilia (RE) ITALY
Tel. +39 0522 1545193
vendite@worky-italy.com
sales@worky-italy.com

www.worky-italy.com

DTE1 - technical datasheet

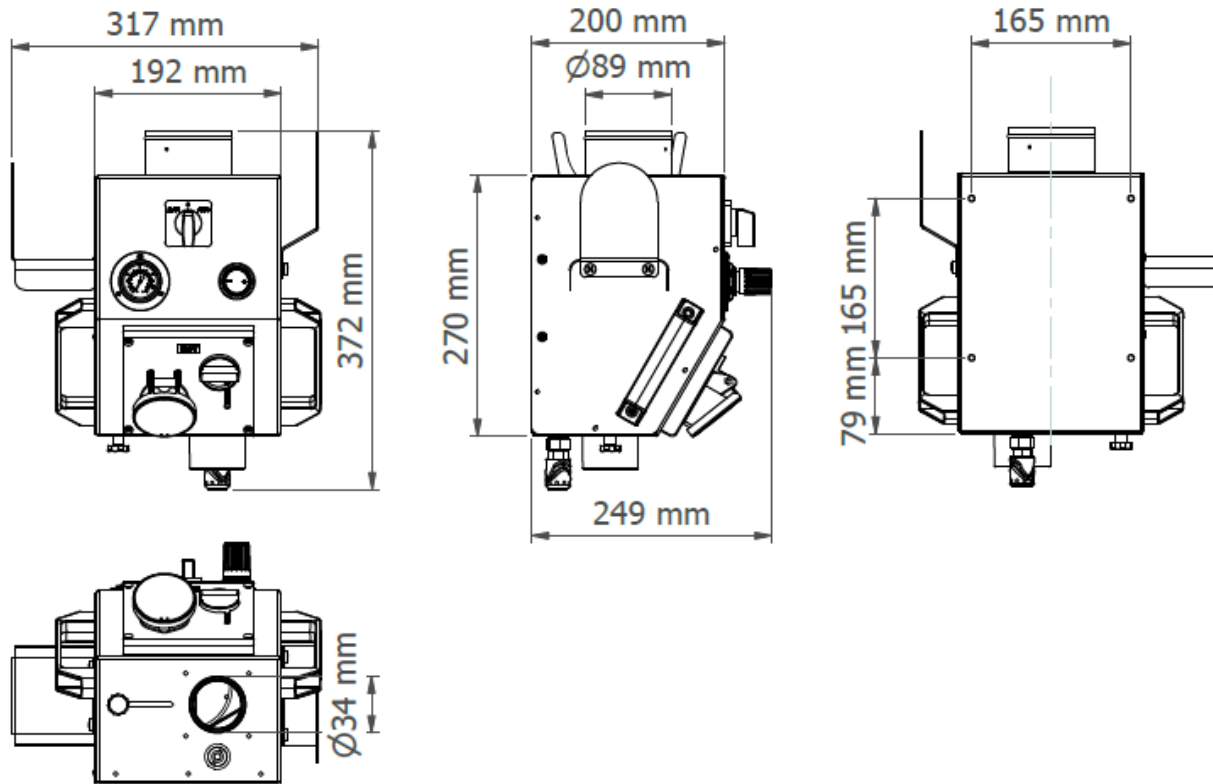

COD	El. conn.	Air. conn.	Aut	Cut	PACK			Kg Tot
					l [mm]	w [mm]	h [mm]	
DTE1	1 x 230V	1 x 3/8"	✓	X	420	330	250	5





THIS DRAWING IS PROPERTY OF DEA + RO & Co S.p.A. THE COMPLETE OR PARTIAL REPRODUCTION OF THIS DOCUMENT IS FORBIDDEN. THE OWNER RESERVES THE RIGHT TO UPDATE, MODIFY OR AMEND ANY SPECIFICATION WITHOUT PRIOR NOTICE.

Rev.00

1/1
10/04/2024



DTEC

-  Scatola di derivazione per collegamenti pneumatici, elettrici e di aspirazione polveri con o senza tubi di collegamento.
-  Connection box for pneumatic, electrical and dust extraction with or without connecting hoses.
-  Satellite simple multi-fonctions avec 1 prise électrique, 1 raccord d'air comprimé (détendu), 1 prise d'aspiration poussières avec registre manuel et interrupteur démarrage centrale d'aspiration.
-  Befestigungsbox inkl. T-Verbindung mit oder ohne 3 mt Abstieg mit Kabel und Schläuche.
-  Caja de conexión neumáticas, eléctricas y de aspiración con o sin tuberías de



DTEC	L.	IN	OUT	FLEX
DTEC	-	ø75 mm	ø75 mm	ø100 mm
DTEC3	3m	ø75 mm	ø75 mm	ø100 mm
DTEC5	5m	ø75 mm	ø75 mm	ø100 mm

DTEC - technical datasheet

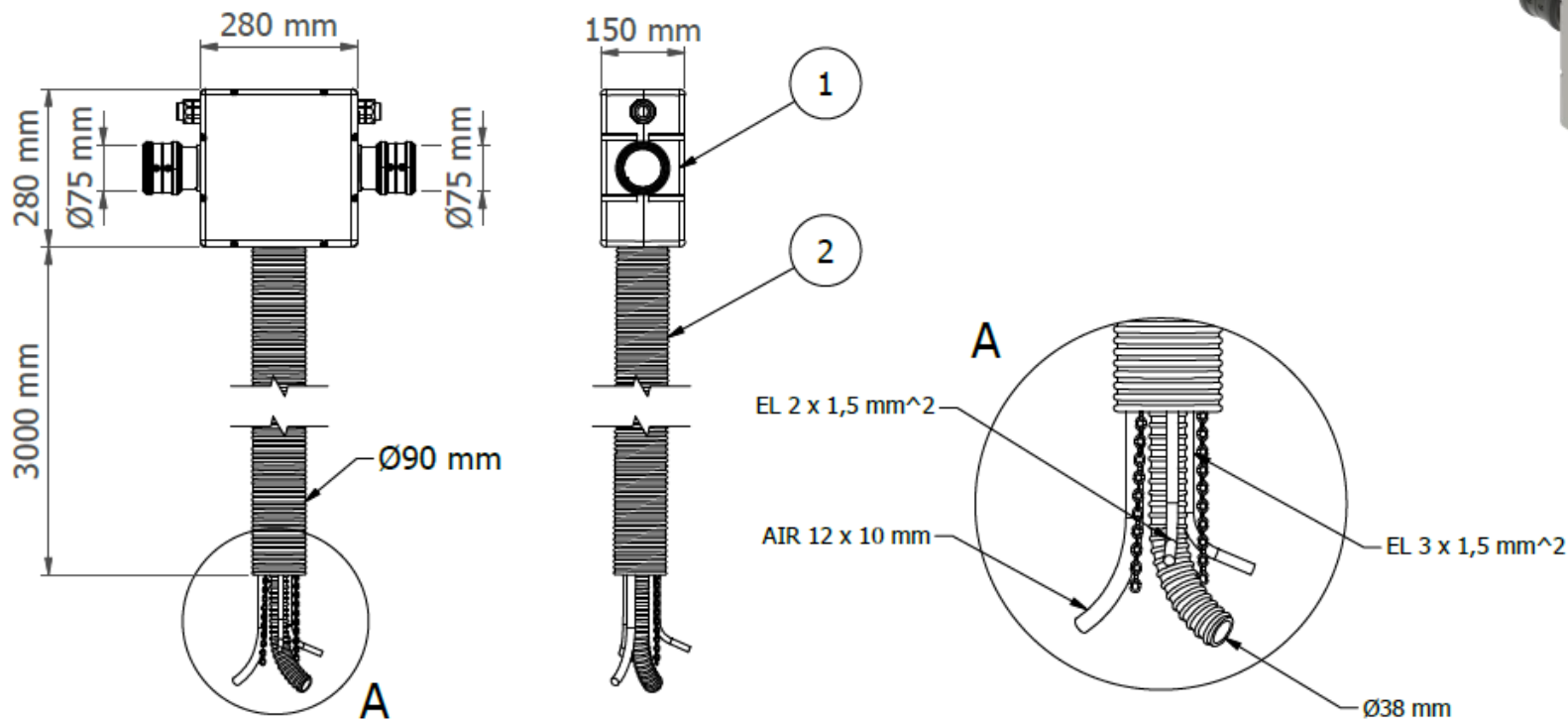

COD	Part 1	Part 2	PACK			Kg Tot
			l [mm]	w [mm]	h [mm]	
DTEC	✓	X	450	450	250	6
DTEC3	✓	✓	1000	500	250	8

DTES

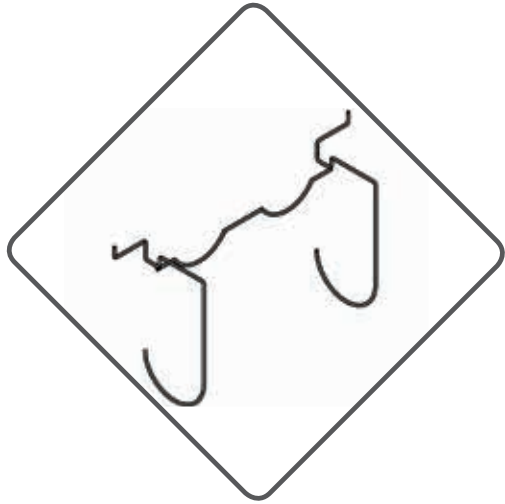

Supporto carteggiatrici e manichette a riposo per centralina di servizio DTE.



Metal support for flexible hoses and sanding machines suitable for DTE service units.



Support métallique pour tuyaux flexibles et ponceses orbitales adapté pour satellites DTE.



Metallhalterung für flexiblen Schläuche und Schleifmaschinen geeignet für DTE Serviceeinheit.



Soporte en acero para mangueras y lijadoras apto para cabezales DTE.

DTES	Nr. tools	Nr. hoses
DTES	Max 2	Max 2

DLEV



Levigatrice orbitale palmare ad azionamento pneumatico con platorello da 150 mm di diametro e regolatore di velocità fino a 10.000 giri al minuto. Predisposizione per l'aspirazione polveri inclusa.



Pneumatic handheld orbital sander with 150 mm diameter platter and speed regulator up to 10,000 rpm. Pre-setting for dust extraction included.



Ponceuse orbitale pneumatique avec plateau de 150 mm de diamètre et régulateur de vitesse jusqu'à 10 000 tr/min. Prédisposition pour l'aspiration de la poussière inclus.



Pneumatischer Hand-Schwingschleifmaschine mit DN 150 mm Platte und Drehzahlregler bis 10.000 U/min. Voreinstellung für Staubabsaugung inbegriffen.



Lijadora orbital con disco de 150 mm de diámetro y regulador de velocidad hasta 10.000 rpm. Preconfiguración para la aspiración de polvo incluida.

DLEV	diam. orb.	r.p.m.	diam.
DLEV3	3 mm	~10.000	150 mm
DLEV6	6 mm	~10.000	150 mm

DY



Deviazione ad Y ridotta da 50 mm a 2 innesti da 29 mm con clapet di chiusura a molla.



Reduced Y piece connection to 2 intakes diam 29 mm equipped with spring operated closing cap.



Déviati^on réduite en "Y" de 50 mm à 2 prises de 29 mm avec clapet de fermeture à ressort.



Reduzierte Y Stück von 50 mm auf 2 Mal 29 mm-Anschlusse mit Federverschlussklappe.



Desviación en Y reducida de 50 mm hasta 2 enchufes de 29 mm con tapa de cierre incluida.

DY2929	Ø1	Ø2	Ø3	Clapet
DY2929	50 mm	29 mm	29 mm	1 x
DY2929-2	50 mm	29 mm	29 mm	2 x

DEP



Presa murale di aspirazione polveri dotata di valvola di chiusura manuale.



Wall mounted dust extraction intake provided with manual closing valve.



Prise murale pour l'aspiration des poussières avec une soupape manuelle intégrée.



Wandmontiert Staubabsaugeinheit mit manueller Absperrklappe imbegriffen.







Toma mural para aspiración de polvo completa de cierre manual.

DEP	Out Ø	Nr. Conn.	Pneum.	Electr.	Valv.
DEP	50 mm	1 x 50mm	-	-	√

DEP2





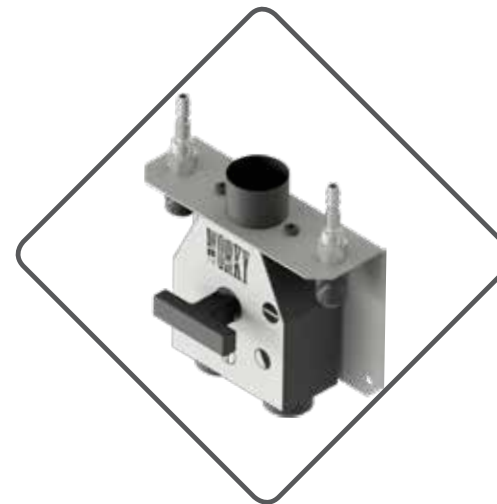

-  Presa pensile doppia per aspirazione polveri dotata di valvola di chiusura manuale.
-  Hanging double dust extraction intake provided with manual closing valve.
-  Double prise suspendue pour l'aspiration des poussières avec une soupape manuelle intégrée.
-  Hangende Doppel-Staubabsaugereinheit mit manueller Absperr- klappe imbegriffen.
-  Toma doble suspendida para aspiración de polvo completa de cierre manual.

DEP2	Out Ø	Nr. Conn.	Pneum.	Electr.	Valv.
DEP2	50 mm	2 x 29mm	-	-	√

DEP2A







-  Presa murale doppia per aspirazione polveri dotata di 2 innesti rapidi per aria compressa e di valvola di chiusura manuale.
-  Wall mounted double dust extraction intake provided 2 quick couplings for compressed air and manual closing valve.
-  Double prise murale pour l'aspiration des poussières avec 2 raccords rapides pour air comprimé et une soupape manuelle intégrée.
-  Wandmontiert Doppel-Staubabsaugereinheit mit manueller Absperrklappe und 2 Druckluftschnellkupplungen imbegriffen.
-  Toma mural doble para aspiración de polvo completa de 2 enchufes rápidos y cierre manual.

DEP2A	Out Ø	Nr. Conn.	Pneum.	Electr.	Valv.
DEP2A	50 mm	2 x 29mm	2	-	√

DM38CL



-  Kit completo con manichetta flessibile diam 38 mm per pulizia veicoli e pavimento.
-  Complete kit with flexible hose 38 mm for vehicle and floor cleaning.
-  Kit complet avec flexible de 38 mm pour l'aspiration des véhicules et du sol.
-  Komplettabsaugatz mit flexiblem Schlauch 38 mm für die Fahrzeug- und Bodenreinigung.
-  Kit completo de aspiración con manguera flexible de 38 mm para limpiar de vehículos y suelo.

DM38-CL	Ø	L.	Pneum.	Electr.
DM38-CL	38 mm	3 m	-	-
DM388CL	38 mm	8 m	-	-



CAT. TURBINE



SCAN THE QR CODE
DOWNLOAD THE
CATALOGUE

CAT. ACCESS.



SCAN THE QR CODE
DOWNLOAD THE
CATALOGUE

CAT. HP REELS



SCAN THE QR CODE
DOWNLOAD THE
CATALOGUE



WORKY[®]

WORKY®

WORKY Headquarters and Production

Via Masaccio, 15 - Z.I. Mancasale
42124 - REGGIO EMILIA (RE) ITALY

Tel. **+39-0522-1545193**

Fax. **+39-0522-1546451**

sales@worky-italy.com

vendite@worky-italy.com

www.worky-italy.com

WORKY North America Inc.

112 South Tryon Street
Suite 1130 Charlotte, North Carolina
28284 USA

Tel **+1 (305) 705 5017**

www.deaworkyna.com



Inquadra il QR Code e scopri il nostro sito!
Frame the QR Code to discover our website!



Seguici su / Follow us on:



QUALITY CERTIFIED ISO 9001:2015