



WORKY®

CANALINE

ALUMINIUM TRACKS

RAILS

SAUGSCHLITZKANÄLE

CARRILES



GAT1

Pag. 6

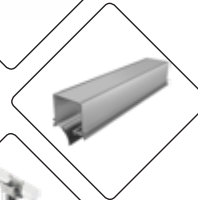

GAT2

Pag. 8



GSCTD

Pag. 12



GSCH

Pag. 14



GCHB

Pag. 16



GCHBV

Pag. 18



GSR+

Pag. 20

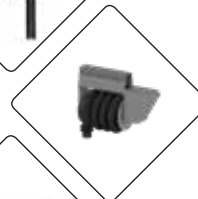

GSRV+

Pag. 22

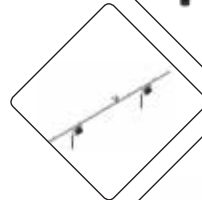

GRK

Pag. 28



GSNK

Pag. 32







GAT

 La canalina GAT, sia nelle versioni GAT1 che GAT2, è un profilo estruso in alluminio modulare dotato di un doppio labbro in gomma di semplice inserimento e dalla straordinaria tenuta all'usura. I due profili hanno sezioni differenti per adattarsi alle varie capacità aspiranti ed hanno i due binari di scorrimento esterni alla sezione aspirante, per mantenere efficiente la movimentazione degli elementi scorrevoli nel tempo. La leggerezza unitamente alla rigida struttura profilata ne rendono facile l'installazione e garantiscono un risultato ottimale per rendere facile l'aspirazione dei gas di scarico.

 The GAT rail, both in GAT1 and GAT2 versions, is a modular aluminum extruded profile fitted with an easy-to-install double rubber lip and extraordinary wear and tear resistance. The two profiles have different sections to adapt to the various suction capacities and have the two outer sliding tracks to the suction chamber to keep the sliding elements moving smoothly over time. The lightness combined with the rigid profile structure make it easy to install and guarantee optimum results for easy vehicle exhaust extraction.

GAT1

 Canalina modulare in estruso di alluminio con labbri di chiusura in gomma e profilo di scorrimento esterno alla camera aspirante. Diametro equivalente di 160 mm e predisposta per staffaggi di sostegno su tutta la lunghezza della barra. Lunghezza barre di 1, 2 o 4 metri.

 Modular extruded aluminum track with rubber lips and sliding profile designed outside the suction chamber. Equivalent diameter of 160 mm and suitable to welcome sliding supporting brackets all over the length of the bar. Available module lengths of 1, 2 or 4 meters.

 Rail modulaire en aluminium extrudé avec lèvres en caoutchouc et profil coulissant conçu à l'extérieur de la chambre d'aspiration. Diamètre équivalent de 160 mm et adapté pour recevoir les supports coulissants tout au long de la barre. Longueurs disponible de 1, 2 ou 4 mètres.

 Modular strangepresster Alu-Saugschlitzkanal mit Gummilippen und Gleitprofil außerhalb der Saugkammer. Äquivalenter Durchmesser von 160 mm und geeignet für gleitenden Stützbügel über die Länge des Kanals. Verfügbare Modullängen von 1, 2 oder 4 Metern.

 Carril modular de aluminio extruido con labios de goma y perfil deslizante diseñado fuera de la cámara de succión. Diámetro equivalente de 160 mm y apto para recibir soportes en toda su longitud. Módulos disponibles de 1, 2 ó 4 metros.

GAT1	Ø mm
H1	158
H2	137
H3	211
H4	115
H5	220

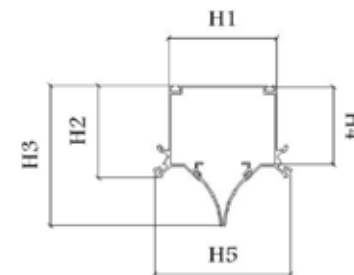

GAT1 - technical datasheet

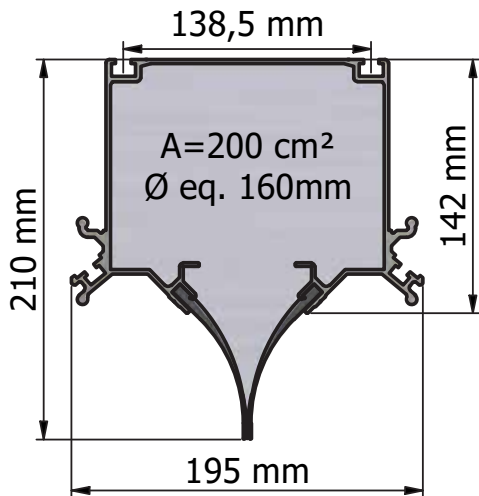

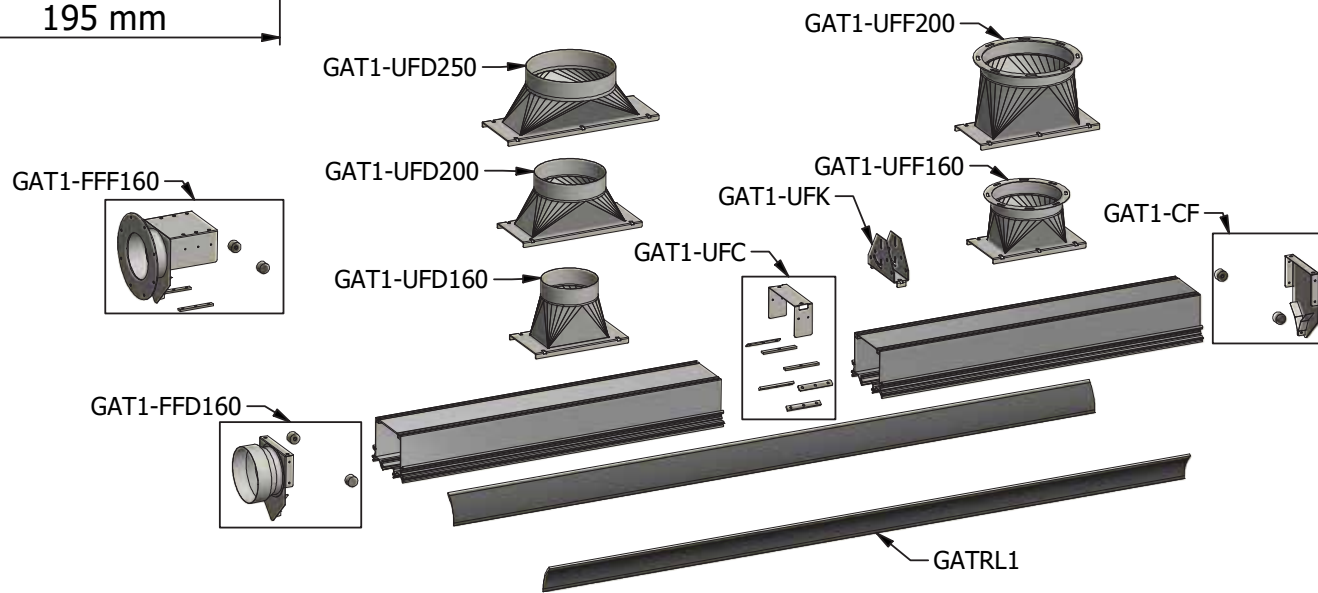
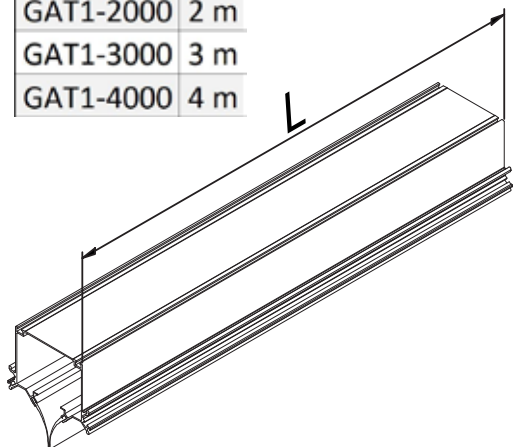

GAT1	L
GAT1-1000	1 m
GAT1-2000	2 m
GAT1-3000	3 m
GAT1-4000	4 m





GAT2

 Canalina modulare in estruso di alluminio con labbri di chiusura in gomma e profilo di scorrimento esterno alla camera aspirante. Diametro equivalente di 202 mm e predisposta per staffaggi di sostegno su tutta la lunghezza della barra. Lunghezza barre di 1, 2 o 4 metri.

 Modular extruded aluminum track with rubber lips and sliding profile designed outside the suction chamber. Equivalent diameter of 202 mm and suitable to welcome sliding supporting brackets all over the length of the bar. Available module lengths of 1, 2 or 4 meters.

 Rail modulaire en aluminium extrudé avec lèvres en caoutchouc et profil coulissant conçu à l'extérieur de la chambre d'aspiration. Diamètre équivalent de 202 mm et adapté pour recevoir les supports coulissants tout au long de la barre. Longueurs disponible de 1, 2 ou 4 mètres.

 Modular strangepresster Alu-Saug Schlitzkanal mit Gummilippen und Gleitprofil außerhalb der Saugkammer. Äquivalenter Durchmesser von 202 mm und geeignet für gleitenden Stützbügel über die Länge des Kanals. Verfügbare Modullängen von 1, 2 oder 4 Metern.

 Carril modular de aluminio extruido con labios de goma y perfil deslizante diseñado fuera de la cámara de succión. Diámetro equivalente de 202 mm y apto para recibir soportes en toda su longitud. Módulos disponibles de 1, 2 ó 4 metros.

GAT1	Ø mm
H1	190
H2	185
H3	260
H4	174
H5	222

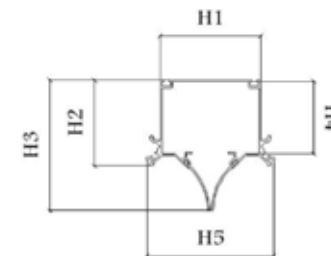



www.worky-italy.com

A brand of RO & Co S.p.A.
 via Masaccio, 15
 42124 Reggio Emilia (RE) ITALY
 Tel. +39 0522 1545193
 vendite@worky-italy.com
 sales@worky-italy.com

GAT2 - technical datasheet

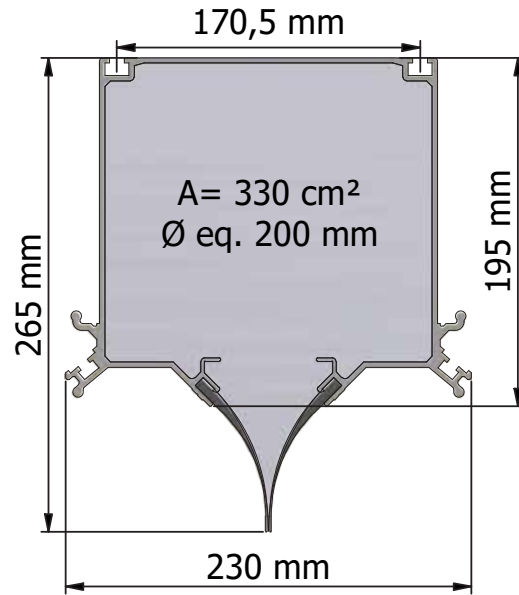

GAT2	L
GAT2-1000	1 m
GAT2-2000	2 m
GAT2-3000	3 m
GAT2-4000	4 m

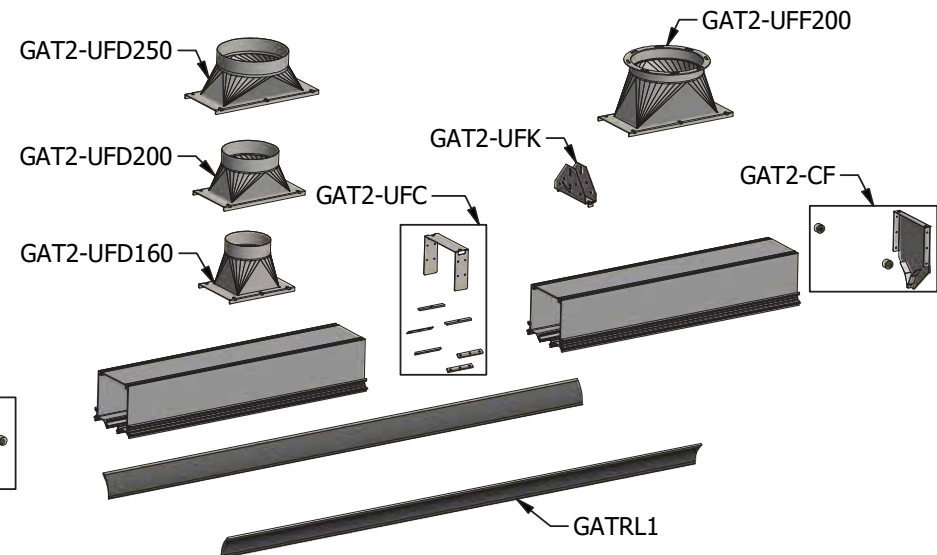
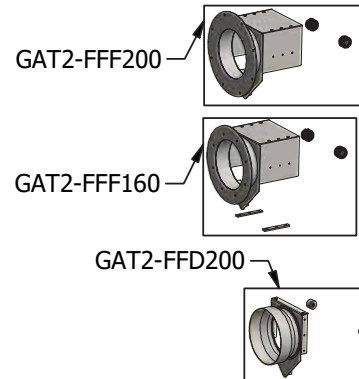
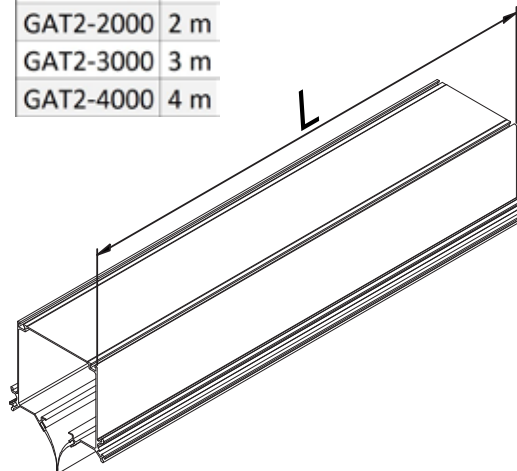

GSTS

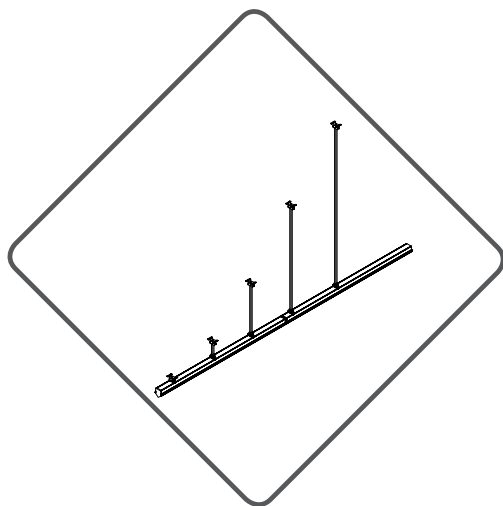

 Staffe in acciaio verniciato con dispositivo di inclinazione per la sospensione a soffitto delle canaline aeree.

 Ceiling brackets in different lengths and inclination device for aluminum track support.

 Étriers de suspension pour rail en plusieurs longueurs avec dispositif d'inclinaison.

 Verschiedene Aufhängungen für Saugschlitzkanäle.

 Estribos en varias longitudes para sujetar el carril.

GSTS	L.	Ø
GSTS	10 cm	3,5 m / 4,0 m
GSTS-05	50 cm	3,5 m / 4,0 m
GSTS-1.5	150 cm	3,5 m / 4,0 m
GSTS-3	300 cm	3,5 m / 4,0 m
GSTS-4.5	450 cm	3,5 m / 4,0 m

GSKT

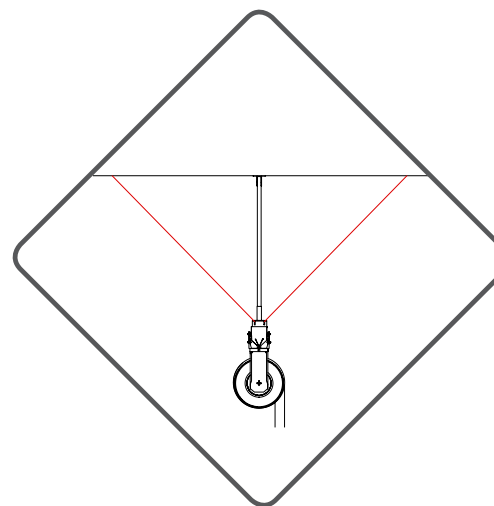

 Kit di tiranti in acciaio per stabilizzare lo staffaggio delle canaline aeree.

 Set of steel cables for balancing the rail supports.

 Set de cables en acier pour stabilisation des étriers.





 Stahlseil für Stabilisierung des Halterungs.

 Set de cables en acero para dar estabilidad a los estribos.

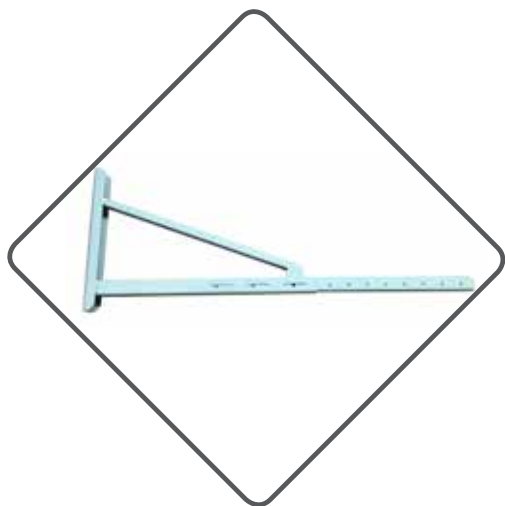
GSKT	L.	Ø
GSKT	2 X 5 m	3 mm
GSKT2	2 X 10 m	3 mm

GSTM





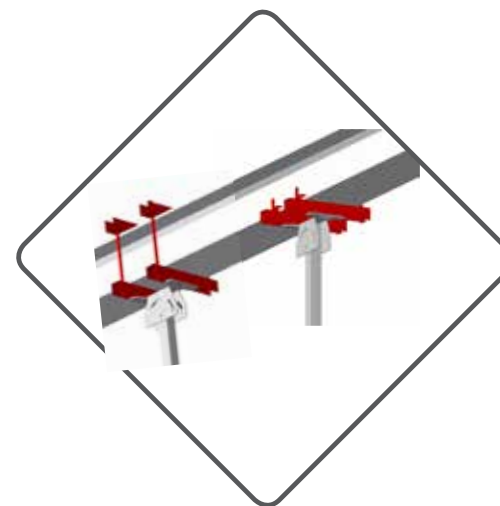

-  Staffe a mensola in acciaio verniciato per supportare a parete le canaline aeree.
-  Ceiling brackets in different lengths and inclination device for aluminum track support.
-  Étriers de suspension murale en plusieurs longueurs pour rails aériens.
-  Regalhalterungen aus lackiertem Stahl für die Wandbefestigung von Saugschlitzkanäle.
-  Soportes a pared en acero pintado para sujetar los carriles aéreos.

GSTM	L.	Spec.
GSTM0.5	500 mm	fix
GSTM1	500 - 1000 mm	adjustable
GSTM1.5	1500 mm	fix
GSTM2	1500 - 2300 mm	adjustable

GKSTS



-  Kit di aggancio su travi IPE/HEA
-  Fixing kit on IPE/HEA beams
-  Kit de fixation sur les poutres IPE/HEA
-  Befestigungssatz für IPE/HEA-Träger
-  Kit de acoplamiento en vigas IPE/HEA

GKSTS	dim. IPE/HEA
GKSTS-IPE	max 400 mm
GKSTS-SB	max 400x400 mm





GSCTD

 Carrello scorrevole per canalina aerea completo di calata telescopica semirigida con 5 mt di tubo flessibile resistente fino a 200°C e bocchetta con serranda manuale.

 Sliding trolley for aluminium track complete with semi-rigid telescopic drop with 5 m hose resistant up to 200°C and nozzle with manual closing valve.

 Chariot coulissant pour rails aériens complet avec tombée télescopique semi-rigide avec flexible de 5 m résistant jusqu'à 200°C et entonnoir avec registre manuel.

 Carro deslizante para railes aéreos completo con bajante telescópica semirrígida con manguera de 5 m resistente hasta 200°C y boquerel con cierre manual

 Carro deslizante para conducto aéreo completo con caída telescópica semirrígida con manguera de 5 m resistente hasta 200°C y boquilla con obturador manual

GAT1



GAT2



GSCTD	Ø	L.
GSCTD100	100 mm	5 m
GSCTD100-GRN	100 mm	5 m
GSCTD100-GRNG	100 mm	5 m
GSCTD100-GON-EG	100 mm	5 m
GSCTD100-GON-MG	100 mm	5 m

GSCTD2	Ø	L.
GSCTD2100	100 mm	5 m
GSCTD2100-GRN	100 mm	5 m
GSCTD2100-GRNG	100 mm	5 m
GSCTD2100-GON-EG	100 mm	5 m
GSCTD2100-GON-MG	100 mm	5 m





GSCH

 Carrello scorrevole per canalina aerea completo di tubazione flessibile GT2 resistente fino a 200°C e fascia di supporto.

 Sliding trolley for aluminum track complete with GT2 flexible hose resistant up to 200°C and support band.

 Chariot coulissant pour rail en aluminium complet avec tuyau flexible GT2 résistant jusqu'à 200°C et bande de support.

 Saugwagen für Alu-Saugschlitzkanal komplett mit GT2-Flexiblerschlauch temperaturbeständig bis 200°C und Stützband.

 Carro deslizante para carril en aluminio completo con manguera flexible GT2 resistente hasta 200°C y banda de soporte.

GAT1



GAT2



GSCH	Ø	L.
GSCH-755	75 mm	5 m
GSCH-757	75 mm	7,5 m
GSCH-7510	75 mm	10 m
GSCH-1005	100 mm	5 m
GSCH-1007	100 mm	7,5 m
GSCH-10010	100 mm	10 m
GSCH-1257	125 mm	7,5 m
GSCH-12510	125 mm	10 m
GSCH-1507	150 mm	7,5 m

GSCH2	Ø	L.
GSCH2-755	75 mm	5 m
GSCH2-757	75 mm	7,5 m
GSCH2-7510	75 mm	10 m
GSCH2-1005	100 mm	5 m
GSCH2-1007	100 mm	7,5 m
GSCH2-10010	100 mm	10 m
GSCH2-1257	125 mm	7,5 m
GSCH2-12510	125 mm	10 m
GSCH2-1507	150 mm	7,5 m

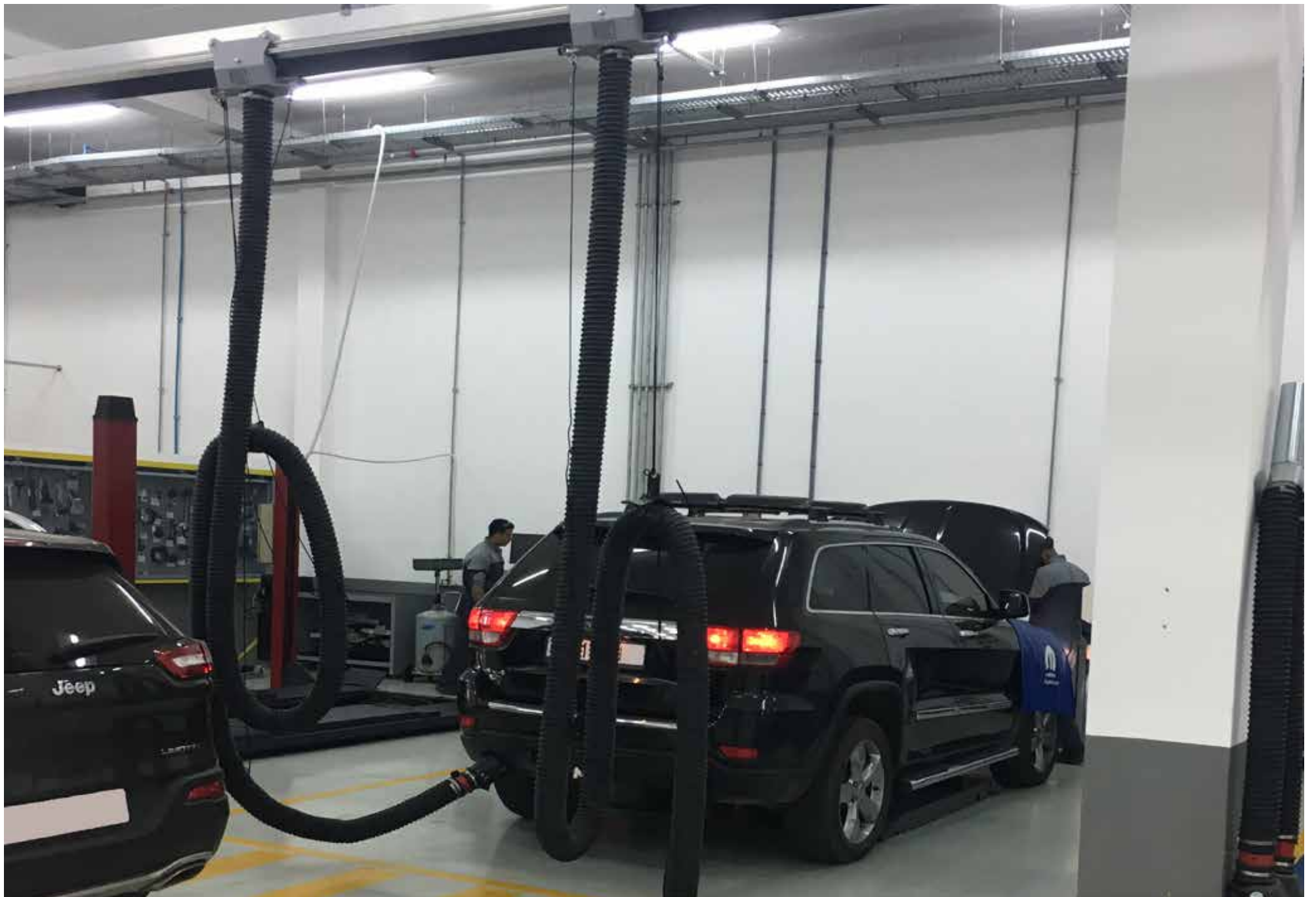

GSCHB



 Carrello scorrevole per canalina aerea completo di tubazione flessibile GT2 resistente fino a 200°C, bilanciere con controscatto e fascia di supporto.

 Sliding trolley for aluminum track complete with GT2 flexible hose resistant up to 200°C, balancer with counter release and supporting band.

 Chariot coulissant pour rail en aluminium complet avec tuyau flexible GT2 résistant jusqu'à 200°C, equilibreur avec cliquet et bande de support.

 Saugwagen für Alu-Saugschlitzkanal komplett mit GT2-Flexiblerschlauch temperaturbeständig bis 200°C, Balanzer und Stützband.

 Carro deslizante para carril en aluminio completo con manguera flexible GT2 resistente hasta 200°C, balanceador con trinquete y banda de soporte.

GAT1



GAT2



GSCHB	Ø	L.
GSCHB-755	75 mm	5 m
GSCHB-757	75 mm	7,5 m
GSCHB-7510	75 mm	10 m
GSCHB-1005	100 mm	5 m
GSCHB-1007	100 mm	7,5 m
GSCHB-10010	100 mm	10 m
GSCHB-1257	125 mm	7,5 m
GSCHB-12510	125 mm	10 m
GSCHB-1507	150 mm	7,5 m

GSCHB2	Ø	L.
GSCHB2-755	75 mm	5 m
GSCHB2-757	75 mm	7,5 m
GSCHB2-7510	75 mm	10 m
GSCHB2-1005	100 mm	5 m
GSCHB2-1007	100 mm	7,5 m
GSCH2-10010	100 mm	10 m
GSCH2-1257	125 mm	7,5 m
GSCH2-12510	125 mm	10 m
GSCH2-1507	150 mm	7,5 m







GSCHBV

 Carrello scorrevole per canalina aerea completo di tubazione flessibile GT2 resistente fino a 200°C, bilanciere con controscatto che comanda una serranda automatica e fascia di supporto.

 Sliding trolley for aluminum track complete with GT2 flexible hose resistant up to 200°C, balancer with counter release with automatic closing valve and supporting band.

 Chariot coulissant pour rail en aluminium complet avec tuyau flexible GT2 résistant jusqu'à 200°C, equilibreur avec cliquet et soupape automatique et bande de support.

 Saugwagen für Alu-Saugschlitzkanal komplett mit GT2-Flexiblerschlauch temperaturbeständig bis 200°C, Balanzer mit automatische Absperrklappe und Stützband.

 Carro deslizante para carril en aluminio completo con manguera flexible GT2 resistente hasta 200°C, balanceador con tapa de cierre automatica y banda de soporte.

GAT1



GAT2



GSCHB	Ø	L.
GSCHBV-755	75 mm	5 m
GSCHBV-757	75 mm	7,5 m
GSCHBV-7510	75 mm	10 m
GSCHBV-1005	100 mm	5 m
GSCHBV-1007	100 mm	7,5 m

GSCHB2	Ø	L.
GSCHBV2-755	75 mm	5 m
GSCHBV2-757	75 mm	7,5 m
GSCHBV2-7510	75 mm	10 m
GSCHBV2-1005	100 mm	5 m
GSCHBV2-1007	100 mm	7,5 m



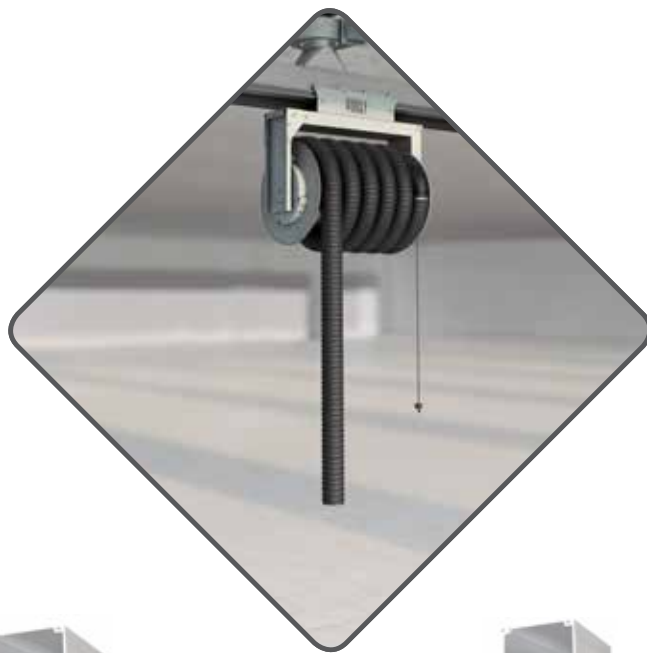

GSR+

GAT1



GAT2



GSR+	Ø	L.
GSR+ -757	75 mm	7,5 m
GSR+ -7510	75 mm	10 m
GSR+ -7512.5	75 mm	12,5 m
GSR+ -1007	100 mm	7,5 m
GSR+ -10010	100 mm	10 m
GSR+ -10012.5	100 mm	12,5 m
GSR+ -1257	125 mm	7,5 m
GSR+ -12510	125 mm	10 m
GSR+ -12512.5	125 mm	12,5 m
GSR+ -1507	150 mm	7,5 m
GSR+ -15010	150 mm	10 m
GSR+ -15012.5	150 mm	12,5 m

GSR2+	Ø	L.
GSR2+ -757	75 mm	7,5 m
GSR2+ -7510	75 mm	10 m
GSR2+ -7512.5	75 mm	12,5 m
GSR2+ -1007	100 mm	7,5 m
GSR2+ -10010	100 mm	10 m
GSR2+ -10012.5	100 mm	12,5 m
GSR2+ -1257	125 mm	7,5 m
GSR2+ -12510	125 mm	10 m
GSR2+ -12512.5	125 mm	12,5 m
GSR2+ -1507	150 mm	7,5 m
GSR2+ -15010	150 mm	10 m
GSR2+ -15012.5	150 mm	12,5 m

 Arrotolatore scorrevole per canalina aerea completo di tubazione flessibile GT2 resistente fino a 200°C e fermatubo di sicurezza. Disponibile anche in versione con serranda automatica interna.

 Sliding hose reel for rail series GAT complete with GT2 200°C resistant hose and hose stopper. Available also with internal automatic closing valve.

 Enrouleur coulissant pour rail GAT, complet avec tuyau flexible et butée de fin de course. Disponible aussi en version avec registre automatique de fermeture.

 Absaugaufroller für Kanal GAT komplett mit GT2 200°C beständigem Schlauch und Stopper. Verfügbar auch mit automatischer Innenabsprerrklappe.

 Enrollador deslizante para carril GAT completo de manguera GT2 resistente hasta 200°C y parada de seguridad. Disponible también en versión con válvula de cierre automática interna.

GSR+ - technical datasheet

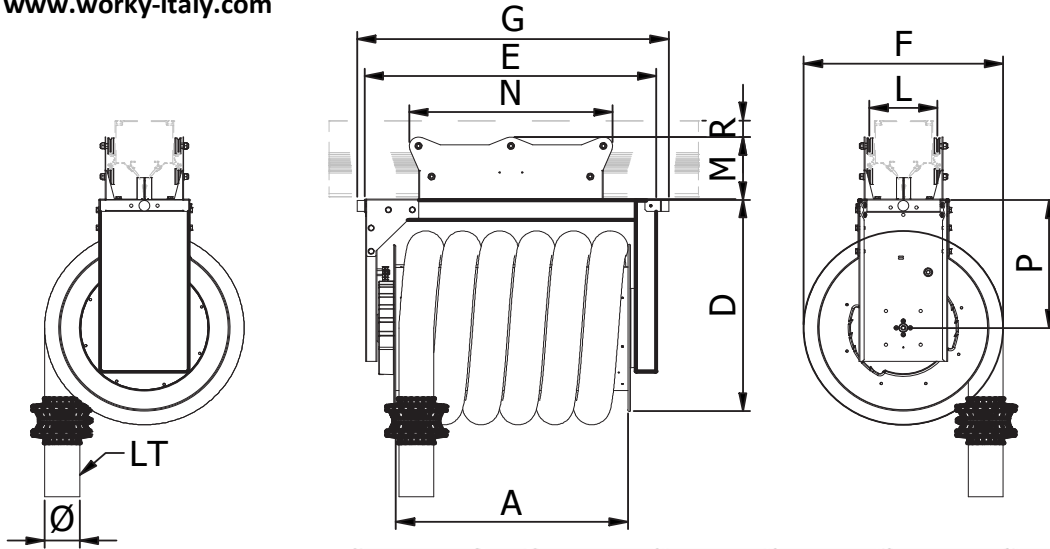

COD.	GSR+												Kg
	Ø[mm]	LT[m]	A[mm]	D[mm]	E[mm]	F[mm]	G[mm]	L[mm]	M[mm]	N[mm]	P[mm]	R[mm]	
GSR+757.5	75	7.5	630	590	785	528	840	185	175	550	356	46	42
GSR+7510		10	800	590	956	528	1013						49
GSR+7512.5		12.5	680	590	879	650	939						59
GSR+1007.5	100	7.5	630	590	785	578	840			41			
GSR+10010		10	800	590	956	578	1013			46			
GSR+10012.5		12.5	850	804	1049	678	1109			60			
GSR+1257.5	125	7.5	680	804	879	730	939			57			
GSR+12510		10	850	804	1049	730	1109			63			
GSR+12512.5		12.5	1080	804	1279	730	1339			72			
GSR+1507.5	150	7.5	680	804	879	780	939			62			
GSR+15010		10	850	804	1049	780	1109			71			
GSR+15012.5		12.5	1080	804	1279	780	1339			75			



GSRV+

GAT1



GAT2



 Arrotolatore scorrevole per canalina aerea completo di tubazione flessibile GT2 resistente fino a 200°C e fermatubo di sicurezza e serranda automatica interna.

 Sliding hose reel for rail series GAT complete with GT2 200°C resistant hose, hose stopper and internal automatic closing valve.

 Enrouleur coulissant pour rail GAT, complet avec tuyau flexible, butée de fin de course et registre automatique de fermeture.

 Absaugaufroller für Kanal GAT komplett mit GT2 200°C beständigem Schlauch, Stopper und automatischer Innenabsprerrklappe.

 Enrollador deslizante para carril GAT completo de manguera GT2 resistente hasta 200°C, parada de seguridad y válvula de cierre automática interna.

GSRV+	Ø	L.
GSRV+757.5	75 mm	7,5 m
GSRV+7510	75 mm	10 m
GSRV+7512.5	75 mm	12,5 m
GSRV+1007.5	100 mm	7,5 m
GSRV+10010	100 mm	10 m
GSRV+10012.5	100 mm	12,5 m
GSRV+12510	125 mm	10 m
GSRV+12512.5	125 mm	12,5 m
GSRV+15010	150 mm	10 m
GSRV+15012.5	150 mm	12,5 m

GSRV2+	Ø	L.
GSRV2+757.5	75 mm	7,5 m
GSRV2+7510	75 mm	10 m
GSRV2+7512.5	75 mm	12,5 m
GSRV2+1007.5	100 mm	7,5 m
GSRV2+10010	100 mm	10 m
GSRV2+10012.5	100 mm	12,5 m
GSRV2+12510	125 mm	10 m
GSRV2+12512.5	125 mm	12,5 m
GSRV2+15010	150 mm	10 m
GSRV2+15012.5	150 mm	12,5 m



www.worky-italy.com

via Masaccio, 15
42124 Reggio Emilia (RE) ITALY
Tel. +39 0522 1545193
vendite@worky-italy.com
sales@worky-italy.com

GSRV+15010 - technical datasheet

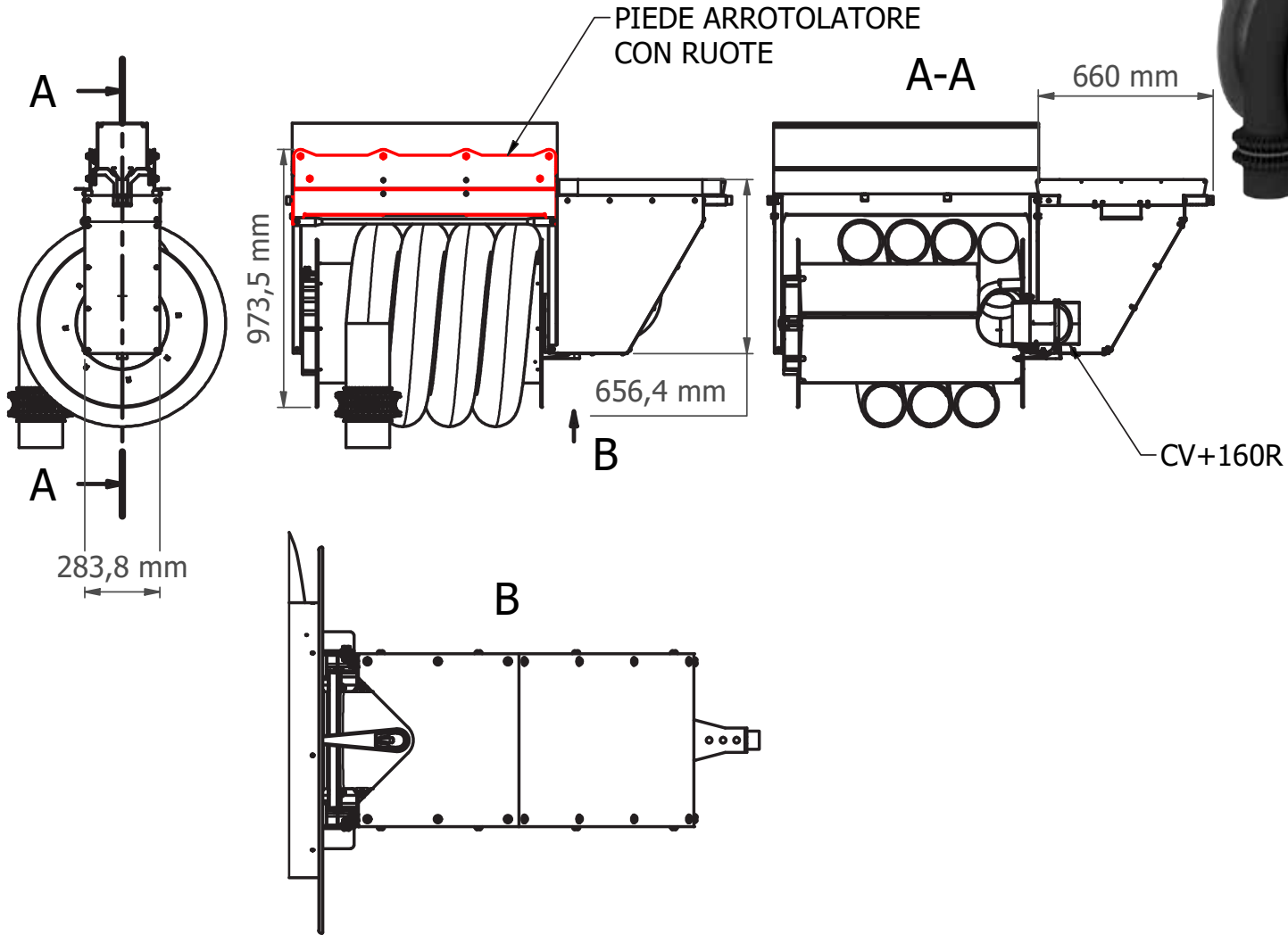









GHH







-  Fascia portatubo di supporto per carrelli scorrevoli con o senza bilanciere
-  Support band for sliding trolleys with or without balancer
-  Bande de support pour flexibles sur chariots coulissants avec ou sans equilibreur universel.
-  Tragband für Schläuche auf Schiebewagen mit oder ohne Balanzer
-  Cinta de soporte para mangueras su carros deslizantes con o sin equilibrador

GHH	Ø
GHH-75	75 mm
GHH-75	100 mm
GHH-125	125 mm

GHH	Ø
GHH-150	150 mm
GHH-200	200 mm
GHHT	HIGH TEMP.

GUB



-  Bilanciere universale con controscatto e fune nautica per il sostegno del tubo flessibile sui carrelli correvoli.
-  Universal balancer with counter-release for hose supporting.
-  Equilibreur universel avec cliquet d'arrêt.
-  Universaler Balanzer mit Arretierung für Schlauchhalterung.
-  Equilibrador universal con trinquete para sujetar la manguera.

GUB	Ø	Max Kg.
GUB100	75 - 100 mm	9
GUB150	125 - 150 mm	13

GM-WIFI





GMG-WIFI





 Microinterruttore WIRELESS azionato dal movimento del bilanciante per effettuare la partenza automatica dell'aspiratore tirando il tubo flessibile. Da collegare ad un quadro elettrico predisposto.

 WIRELESS microswitch activated by the balancer movement, to start the fan just by pulling the flexible hose. To be connected to a compatible control board.

 Micro interrupteur WIRELESS commandé par le mouvement de l'équilibreur pour mettre en marche l'aspirateur en tirant le tuyau flexible. Il faut le connecter à un tableau électrique spécial

 WIRELESS Mikroschalter für das automatische Start/Stop des Ventilators durch Aufrollerbewegung. An einen vorbereiteten Schutzschalter zu verbinden (nicht inbegriffen).

 Micro interruptor WIRELESS, accionado por el equilibrador, para la puesta en marcha automática del extractor. Para conectar a un cuadro eléctrico preparado.

 Microinterruttore WIRELESS azionato dal movimento del bilanciante per effettuare la partenza automatica dell'aspiratore tirando il tubo flessibile. Da collegare WIRELESS ad un quadro elettrico predisposto.

 WIRELESS microswitch activated by the balancer movement, to start the fan just by pulling the flexible hose. To be connected to a compatible control board.

 Micro interrupteur WIRELESS actionné par la rotation de l'équilibreur pour effectuer le démarrage automatique de l'aspirateur en tirant sur le tuyau. à connecter sans fils avec un coffret compatible.

 WIRELESS Mikroschalter für das automatische Start/Stop des Ventilators durch Balanzerbewegung. An einen vorbereiteten Schutzschalter zu verbinden (nicht inbegriffen).

 Micro interruptor WIRELESS, accionado por el equilibrador, para la puesta en marcha automática del extractor. Para conectar a un cuadro eléctrico preparado.

GM-WIFI	Applic.
GM-WIFI	GSR - GMR

GMG-WIFI	Applic.
GMG-WIFI	GUB





GRK

 I kit GRK sono la risposta veloce e immediata per proporre un kit completo di canalina di varia lunghezza con elementi scorrevoli in base alle zone di lavoro da servire. Basta completarli con i materiali per adattarsi all'applicazione (bocchette, staffe di supporto, camino di espulsione, interruttore) e l'impianto è fatto.

Il READY KIT è studiato per servire le zone di lavoro in linea partendo da un minimo di 2 fino ad un massimo di 7... anche se la sua estrema modularità ci permette di ampliarlo secondo necessità. Il prodotto presenta le versioni con carrello scorrevole, arrotolatore scorrevole e il nuovo sistema universale TOUCHLESS (senza contatto col veicolo).

 GRK kits provide a quick answer for proposing complete rail systems of multiple lengths and with sliding elements according to the number of work bays. You just need to add the variables that best suit the case (nozzles, brackets, chimney, switch) and the system is done! The READY KIT is designed to serve from 2 to 7 work bays in line, even if, thanks to its extreme flexibility, we can extend it as much as required. This product has several versions: with sliding trolleys, with hose reels and with the latest system, the universal GTL TOUCHLESS (contactless solution).

 Les kits GRK constituent une réponse rapide pour desservir les zones de travail par un kit complet avec rails de différentes longueurs et ses éléments coulissants. Il suffit de les compléter avec les composants pour s'adapter à l'application (entonnoirs, brides de support, cheminée d'expulsion, interrupteur) et le système est terminé. Le READY KIT est conçu pour desservir des zones de travail en ligne d'un minimum de 2 à un maximum de 7 ... même si sa modularité extrême nous permet de l'agrandir au besoin. Le produit présente des versions avec chariot coulissant, enrouleur coulissant et le nouveau système universel TOUCHLESS (sans contact avec le véhicule).

 Die GRK-Kits sind die schnellsten und sofortigen Antworten, um ein komplettes Saugschlitzkanal-Set mit verschiedenen Längen mit schlitzbaren Elementen abhängig von Arbeitsbereichen vorzuschlagen. Man braucht nur Projekt spezifisches Elementen hinzufügen (Düsen, Halterungen, Ausblastsatz, Schalter) und die Anlage ist fertig. Das READY KIT ist geeignet für Werkstatt ab 2 bis 7 Arbeitsplätze in einer Reihe, obwohl es aufgrund seiner extremen Modularität möglich ist, es nach Bedarf zu erweitern. Mehrere Ausführungen verfügbar: mit Schlauchwagen, Schlauchaufroller und dem neuen TOUCHLESS-Universalsystem (ohne Kontakt zum Fahrzeug).

 Los kits de GRK son la respuesta rápida e inmediata para proponer un kit completo de varias longitudes con elementos deslizantes según las zonas de trabajo del taller. Simplemente complete con los materiales específicos del proyecto (boqueras, soportes, chimenea, interruptor) y el equipo ya está hecho. El READY KIT está diseñado para servir zonas de trabajo en línea que van desde un mínimo de 2 hasta un máximo de 7 ... aunque su modularidad extrema nos permite expandirlo según necesidad. El producto presenta versiones con carro y enrollador deslizantes y el nuevo sistema universal TOUCHLESS (sin contacto con el vehículo).



GRK1

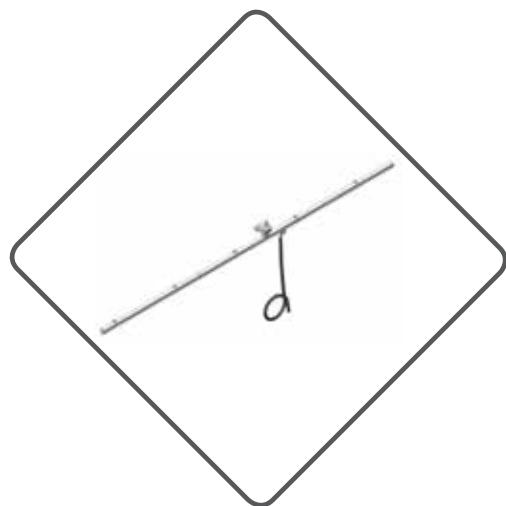

 Kit di canalina con 1 carrello scorrevole e aspiratore

 Rail kit with 1 sliding trolley and fan

 Kit de rails avec 1 chariot coulissant et aspirateur

 Saugschlitzkanalsatz mit 1 Schiebewagen und ventilator

 Kit de carril con 1 carro deslizante y aspirador

GRK1 - 75	GRK1 -100	GRK1 - 125	GRK1 - 150
GRK1-75-8	GRK1-100-8	GRK1-125-12	GRK1-150-12
GRK1-75-12	GRK1-100-12	GRK1-125-16	GRK1-125-16
GRK1-75-16	GRK1-100-16	GRK1-125-20	GRK1-125-20
GRK1-75-20	GRK1-100-20	GRK1-125-24	GRK1-125-24
GRK1-75-24	GRK1-100-24	GRK1-125-28	GRK1-125-28

GRK2

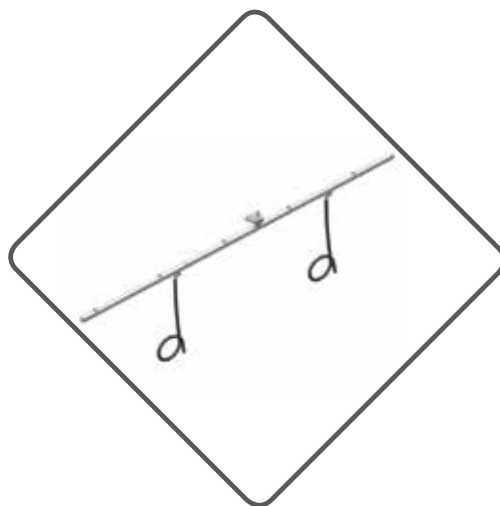

 Kit di canalina con 2 carrelli scorrevoli e aspiratore

 Rail kit with 2 sliding trolleys and fan

 Kit de rails avec 2 chariots coulissants et aspirateur

 Saugschlitzkanalsatz mit 2 Schiebewagen und ventilator

 Kit de carril con 2 carros deslizantes y aspirador

GRK2 - 75	GRK2- 100	GRK2 - 125	GRK2 - 150
GRK2-75-8	GRK2-100-8	GRK2-125-12	GRK2-150-12
GRK2-75-12	GRK2-100-12	GRK2-125-16	GRK2-125-16
GRK2-75-16	GRK2-100-16	GRK2-125-20	GRK2-125-20
GRK2-75-20	GRK2-100-20	GRK2-125-24	GRK2-125-24
GRK2-75-24	GRK2-100-24	GRK2-125-28	GRK2-125-28

GRK3

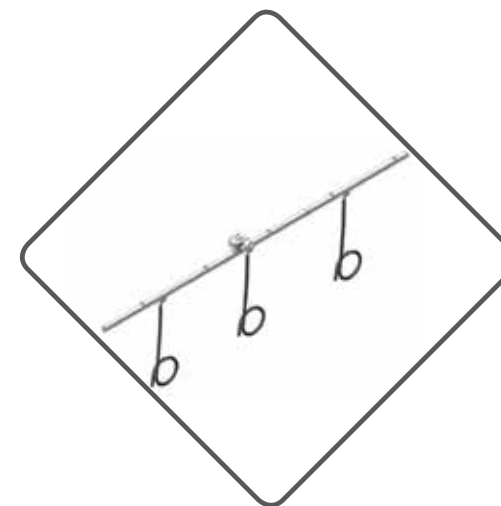

 Kit di canalina con 3 carrelli scorrevoli e aspiratore

 Rail kit with 3 sliding trolleys and fan

 Kit de rails avec 3 chariots coulissants et aspirateur





 Saugschlitzkanalsatz mit 3 Schiebewagen und ventilator

 Kit de carril con 3 carros deslizantes y aspirador

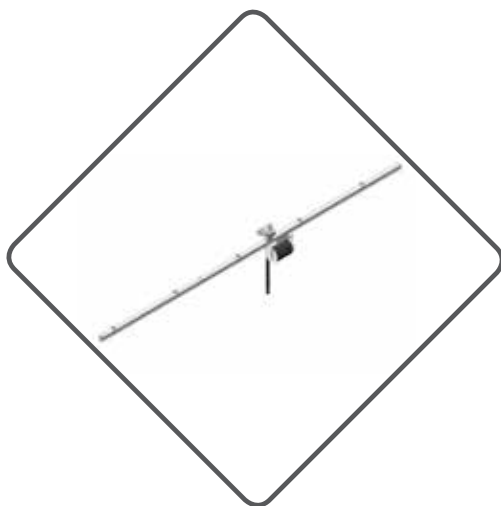
GRK3 - 75	GRK3- 100	GRK3 - 125	GRK3- 150
GRK3-75-12	GRK3-100-12	GRK3-125-16	GRK3-125-16
GRK3-75-16	GRK3-100-16	GRK3-125-20	GRK3-125-20
GRK3-75-20	GRK3-100-20	GRK3-125-24	GRK3-125-24
GRK3-75-24	GRK3-100-24	GRK3-125-28	GRK3-125-28

GRK1R





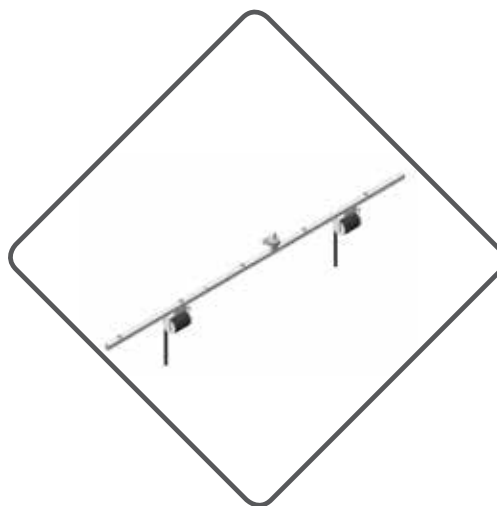

-  Kit di canalina con 1 arrotolatore scorrevole e aspiratore
-  Rail kit with 1 sliding hose reel and fan
-  Kit de rails avec 1 enrouleur coulissant et aspirateur
-  Saugschlitzkanalsatz mit 1 Schiebeaufroller und ventilator
-  Kit de carril con 1 enrollador deslizante y aspirador

GRK1R - 75	GRK1R - 100	GRK1R - 125	GRK1R - 150
GRK1R-75-8	GRK1R-100-8	GRK1R-125-12	GRK1R-150-12
GRK1R-75-12	GRK1R-100-12	GRK1R-125-16	GRK1R-125-16
GRK1R-75-16	GRK1R-100-16	GRK1R-125-20	GRK1R-125-20
GRK1R-75-20	GRK1R-100-20	GRK1R-125-24	GRK1R-125-24
GRK1R-75-24	GRK1R-100-24	GRK1R-125-28	GRK1R-125-28

GRK2R





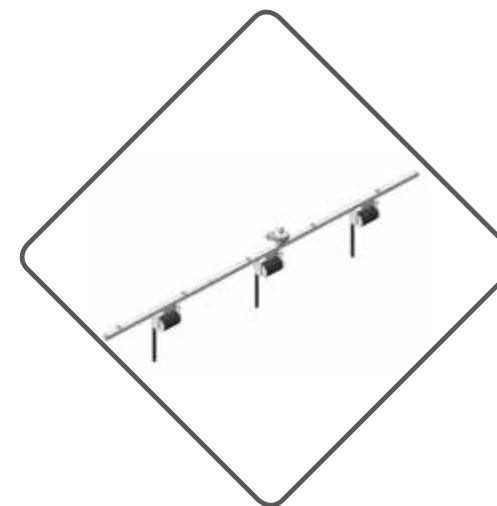

-  Kit di canalina con 2 arrotolatori scorrevoli e aspiratore
-  Rail kit with 2 sliding hose reels and fan
-  Kit de rails avec 2 enrouleurs coulissants et aspirateur
-  Kanalsatz mit 2 Schiebeaufrollern und ventilator
-  Kit de carril con 2 enrolladores deslizantes y aspirador

GRK2R - 75	GRK2R - 100	GRK2R - 125	GRK2R - 150
GRK2R-75-8	GRK2R-100-8	GRK2R-125-12	GRK2R-150-12
GRK2R-75-12	GRK2R-100-12	GRK2R-125-16	GRK2R-125-16
GRK2R-75-16	GRK2R-100-16	GRK2R-125-20	GRK2R-125-20
GRK2R-75-20	GRK2R-100-20	GRK2R-125-24	GRK2R-125-24
GRK2R-75-24	GRK2R-100-24	GRK2R-125-28	GRK2R-125-28

GRK3R





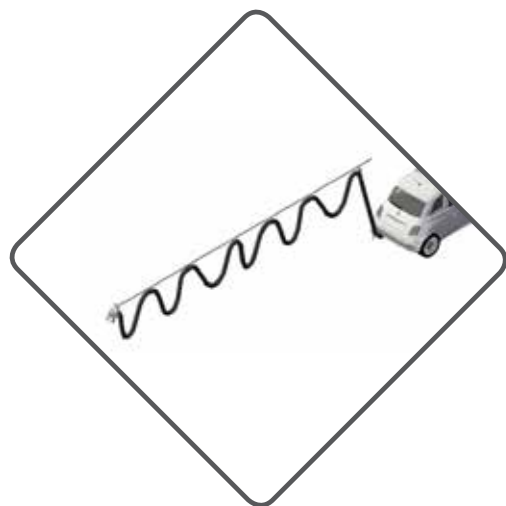

-  Kit di canalina con 3 arrotolatori scorrevoli e aspiratore
-  Rail kit with 3 sliding hose reels and fan
-  Kit de rails avec 3 enrouleurs coulissants et aspirateur
-  Kanalsatz mit 3 Schiebeaufrollern und ventilator
-  Kit de carril con 3 enrolladores deslizantes y aspirador

GRK3R - 75	GRK3R - 100	GRK3R - 125	GRK3R - 150
GRK3R-75-12	GRK3R-100-12	GRK3R-125-16	GRK3R-125-16
GRK3R-75-16	GRK3R-100-16	GRK3R-125-20	GRK3R-125-20
GRK3R-75-20	GRK3R-100-20	GRK3R-125-24	GRK3R-125-24
GRK3R-75-24	GRK3R-100-24	GRK3R-125-28	GRK3R-125-28

GSNK





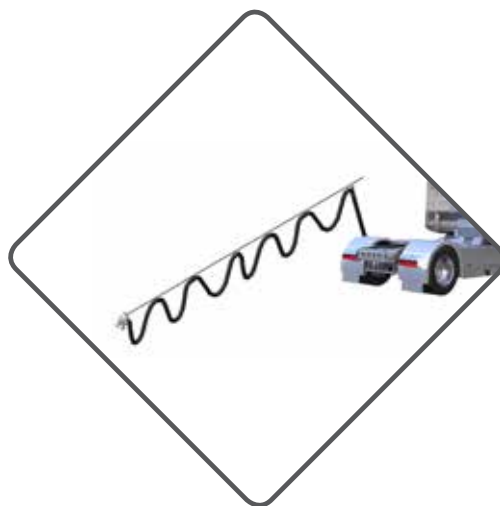

-  Kit a festoni per revisione auto con ritorno automatico
-  Kit for car MOT test with automatic return of the trolley
-  Kit pour le controle technique des VL avec retour automatique
-  Satz PKW für Bremsenprüfstrasse mit automatischer Rückführung
-  Kit para ITV turismos con regreso automático del carro.

GSNK	Ø	L.	HP
GSNK-100-8	100 mm	8 m	1
GSNK-100-12	100 mm	12 m	1
GSNK-100-16	100 mm	16 m	1
GSNK-100-20	100 mm	20 m	1

GSNK





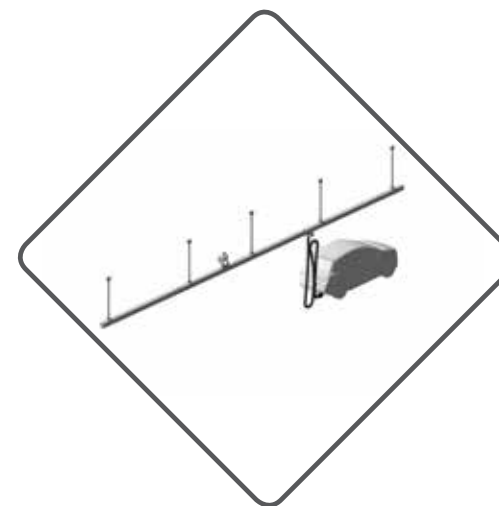

-  Kit a festoni per revisione camion con ritorno automatico
-  Kit for truck MOT test with automatic return of the trolley
-  Kit pour le controle technique des PL avec retour automatique
-  Satz LKW für Bremsenprüfstrasse mit automatischer Rückführung
-  Kit para ITV camiones con regreso automático del carro.

GSNK	Ø	L.	HP
GSNK-150-16	150 mm	16 m	1,5
GSNK-150-20	150 mm	20 m	1,5
GSNK-150-24	150 mm	24 m	1,5

GDK



-  Kit di aspirazione con canalina per revisione veicoli
-  Exhaust extraction rail kit for MOT test
-  Kit aspiration avec rail pour le controle technique
-  Abgas-Absaugatz mit Saugschlitzkanal für Bremsenprüfstrasse
-  Kit aspiración con carril para ITV

GDK	Ø	L.	HP	GDK	Ø	L.	HP
GDK-100-8	100 mm	8m	1	GDK-150-16	150 mm	16m	1,5
GDK-100-12	100 mm	12m	1	GDK-150-20	150 mm	20m	1,5
GDK-100-16	100 mm	16m	1	GDK-150-24	150 mm	24m	1,5
GDK-100-20	100 mm	20m	1				

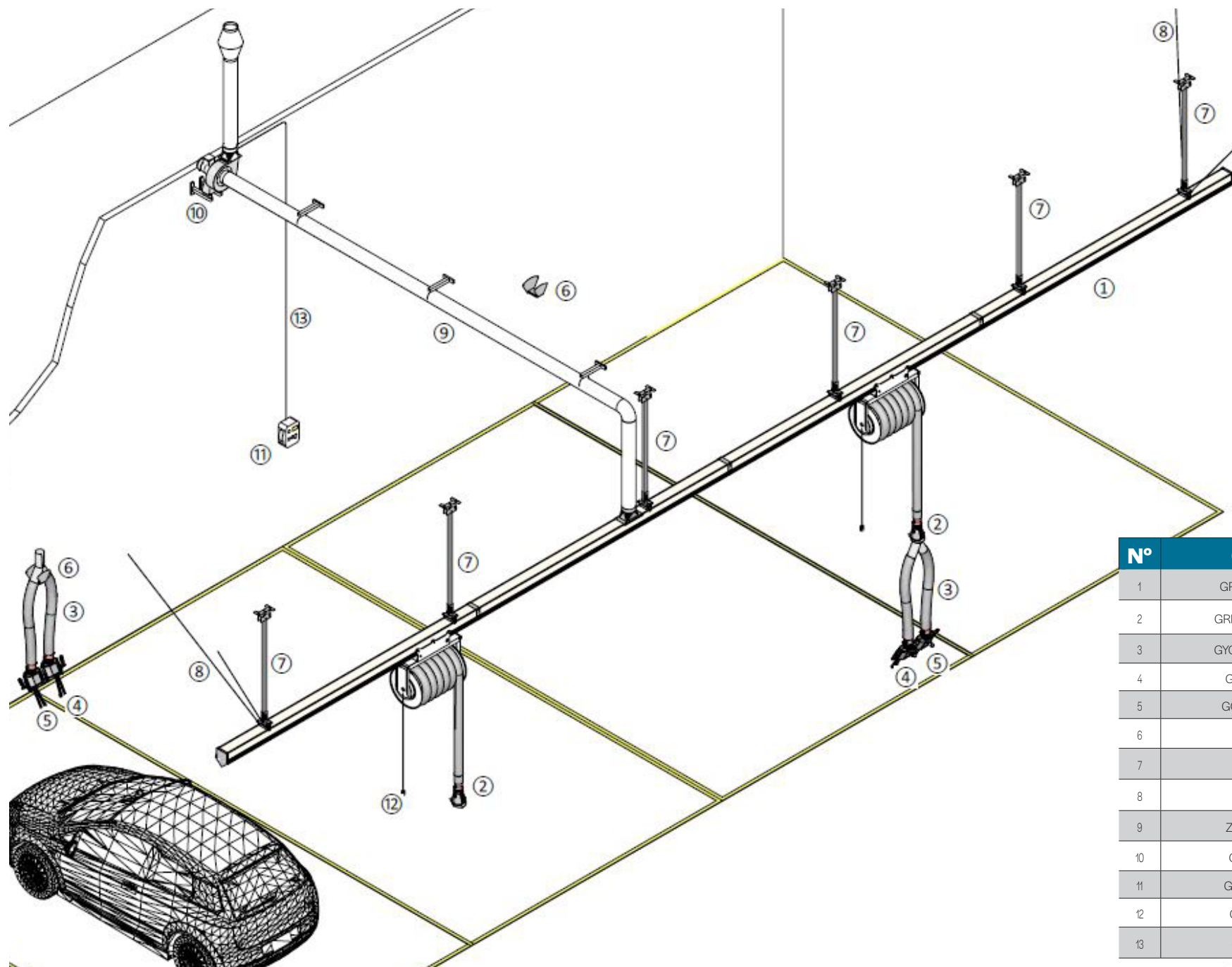

N°	COD.	Q
1	GRK2R-100-16	1
2	GRNGM-160100	2
3	GYG-100100100	2
4	GON-100EG	2
5	GON-100EGR	2
6	GWB-100	2
7	GSTS-1.5	6
8	GSKT	6
9	ZGS160KC4	1
10	GRKTK1-1.5	1
11	GSQEDW-1.5	1
12	GSQEDRC	1
13	CVE-4X1.5	5

WORKY[®]

CAT. ACCESS. CAT. VENTILAT. CAT. NOZZLES



SCAN THE QR CODE
DOWNLOAD THE
CATALOGUE



SCAN THE QR CODE
DOWNLOAD THE
CATALOGUE



SCAN THE QR CODE
DOWNLOAD THE
CATALOGUE



WORKY®

WORKY Headquarters and Production

Via Masaccio, 15 - Z.I. Mancasale
42124 - REGGIO EMILIA (RE) ITALY

Tel. **+39-0522-1545193**

Fax. **+39-0522-1546451**

sales@worky-italy.com

vendite@worky-italy.com

www.worky-italy.com

WORKY North America Inc.

112 South Tryon Street
Suite 1130 Charlotte, North Carolina
28284 USA

Tel **+1 (305) 705 5017**

www.deaworkyna.com



Inquadra il QR Code e scopri il nostro sito!
Frame the QR Code to discover our website!



Seguici su / Follow us on:



QUALITY CERTIFIED ISO 9001:2015