



# WORKY®

SB - BRACCI ARTICOLATI

SB - ARTICULATED ARMS

SB- BRAS ARTICULÉS

SB- GELENKARME

SB - BRAZOS ARTICULADOS





	<b>SB</b> Pag. 4
	<b>SBB</b> Pag. 8
	<b>SBBA</b> Pag. 14
	<b>SBF</b> Pag. 16
	<b>SBBF</b> Pag. 24
	<b>SBBFA</b> Pag. 26
	<b>SPECIAL</b> Pag. 28





# SB



 I bracci aspiranti snodati della serie SB di WORKY sono soluzioni avanzate per l'aspirazione dei fumi di saldatura direttamente dalla zona di lavoro. Dotati di almeno tre articolazioni, garantiscono massima manovrabilità e stabilità nella posizione desiderata, assicurando l'aspirazione dei fumi nel momento stesso in cui vengono generati senza dispersioni nell'ambiente. Disponibili in lunghezze da 2 a 9 metri e con diametri da 150 o 200 mm per gli impieghi più gravosi.

 The articulated extractor arms of WORKY's SB series are advanced solutions for extracting welding fumes directly from the work area. Equipped with at least three joints, they ensure maximum maneuverability and stability in the desired position, guaranteeing the extraction of fumes at the very moment they are generated without dispersion into the environment. Available in lengths from 2 to 9 meters and with diameters of 150 or 200 mm for the most demanding applications.

 Les bras aspirants articulés de la série SB de WORKY sont des solutions avancées pour l'aspiration des fumées de soudage directement depuis la zone de travail. Équipés d'au moins trois articulations, ils garantissent une maniabilité maximale et une stabilité dans la position désirée, assurant l'aspiration des fumées au moment même où elles sont générées, sans dispersion dans l'environnement. Disponibles en longueurs de 2 à 9 mètres et avec des diamètres de 150 ou 200 mm pour les applications les plus exigeantes.

 Die gelenkigen Absaugarme der SB-Serie von WORKY sind fortschrittliche Lösungen zur Absaugung von Schweißrauch direkt aus dem Arbeitsbereich. Ausgestattet mit mindestens drei Gelenken gewährleisten sie maximale Beweglichkeit und Stabilität in der gewünschten Position und sorgen dafür, dass die Rauchabsaugung genau zum Zeitpunkt der Entstehung erfolgt, ohne sich in der Umgebung zu verbreiten. Erhältlich in Längen von 2 bis 9 Metern und mit Durchmessern von 150 oder 200 mm für besonders anspruchsvolle Anwendungen.

 Los brazos de extracción articulados de la serie SB de WORKY son soluciones avanzadas para la extracción de humos de soldadura directamente desde el área de trabajo. Equipados con al menos tres articulaciones, garantizan máxima maniobrabilidad y estabilidad en la posición deseada, asegurando la extracción de humos en el mismo momento en que se generan, sin dispersión en el ambiente. Disponibles en longitudes de 2 a 9 metros y con diámetros de 150 o 200 mm para las aplicaciones más exigentes.



# SB



 Braccio articolato Ø 150 mm autoportante con mensola a parete, parallelogramma esterno di supporto, cappetta in materiale plastico, rete interna di protezione e farfalla di parzializzazione del flusso aspirato.

 Self-supporting articulated arm Ø 150 mm with wall bracket, external support parallelogram, plastic hood, internal protection net and suction flow butterfly flap.

 Bras articulé autoportant Ø 150 mm avec support mural, parallélogramme de support externe, hotte en plastique, chiffon de protection interne et régulateur de débit d'aspiration.

 Selbsttragender Gelenkarm Ø 150 mm mit Wandhalterung, äußerem Stützparallelogramm, Kunststoffhaube, innerem Schutznetz und Saugstromdrossel.

 Brazo articulado autoportante Ø 150 mm con soporte mural, paralelogramo de soporte externo, campana de plástico, red de protección interna y valvula para réglar de flujo de aspiración.

CODE	DIAM.	L.
<b>SB2</b>	150 MM	2 M
<b>SB3</b>	150 MM	3 M
<b>SB4</b>	150 MM	4 M
<b>SB5</b>	150 MM	5 M



via Masaccio, 15  
42124 Reggio Emilia (RE) ITALY  
Tel. +39 0522 1545193  
vendite@worky-italy.com  
sales@worky-italy.com

### SB - technical datasheet

www.worky-italy.com

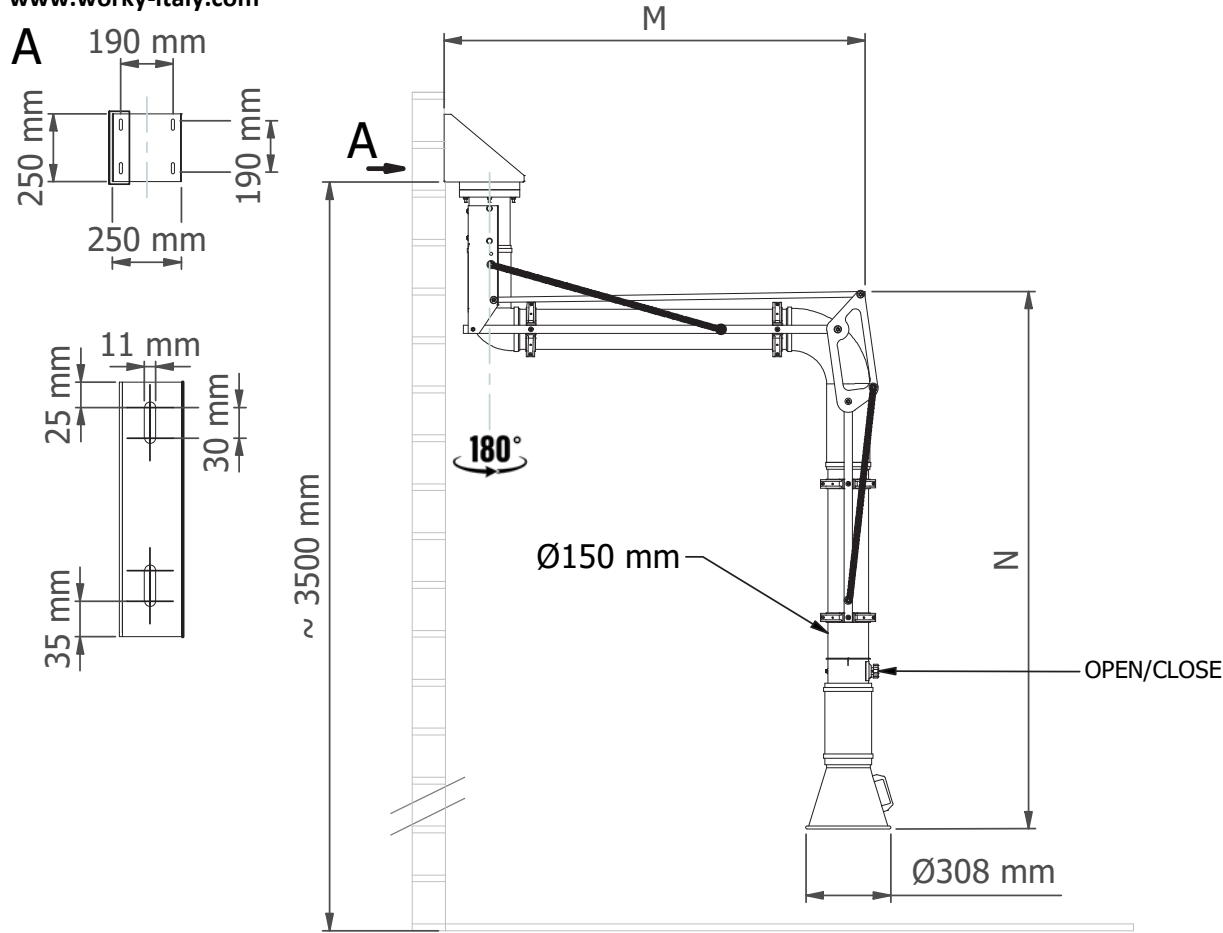

COD	M+N [mm]	Ø [mm]	PACK			
			l [mm]	w [mm]	h [mm]	Kg
SB2	2600	150	1750	800	550	47
SB3	3200	150	1750			50
SB4	4200	150	2400			53

THIS DRAWING IS PROPERTY OF DEA + RO & Co S.p.A. THE COMPLETE OR PARTIAL REPRODUCTION OF THIS DOCUMENT IS FORBIDDEN. THE OWNER RESERVES THE RIGHT TO UPDATE, MODIFY OR AMEND ANY SPECIFICATION WITHOUT PRIOR NOTICE.

Rev.00

06/02/2024

1/1

# SBB



 Braccio articolato con parallelogramma esterno di supporto montato su prolunga a bandiera tramite ralla rotante a 360° per una grande movimentazione fino ad una lunghezza massima di 9 mt totali.

 Articulated arm with external support parallelogram mounted on a wall boom extension via a 360° rotating joint, allowing wide movement with a total maximum length of up to 9 meters.

 Bras articulé avec parallélogramme de support externe monté sur une rallonge murale via une rotule rotative à 360°, permettant une grande amplitude de mouvement jusqu'à une longueur totale maximale de 9 mètres.

 Gelenkarm mit externem Stützparallelogramm, montiert auf einer Wandauslegerverlängerung über ein 360° drehbares Gelenk, für große Bewegungsfreiheit bei einer maximalen Gesamtlänge von bis zu 9 Metern.

 Brazo articulado con paralelogramo de soporte externo montado sobre una extensión mural en voladizo mediante rótula giratoria de 360°, que permite un amplio movimiento hasta una longitud total máxima de 9 metros.

CODE	PART 1	PART 2	DIAM.	L. TOT
<b>SBB6</b>	SBAN2	SB4-SM	150 MM	6,2 M
<b>SBB7</b>	SBAN3	SB4-SM	150 MM	7,2 M
<b>SBB8</b>	SBAN4	SB4-SM	150 MM	8,2 M
<b>SBB9</b>	SBAN4	SB5-SM	150 MM	9,2 M

SBB - technical datasheet

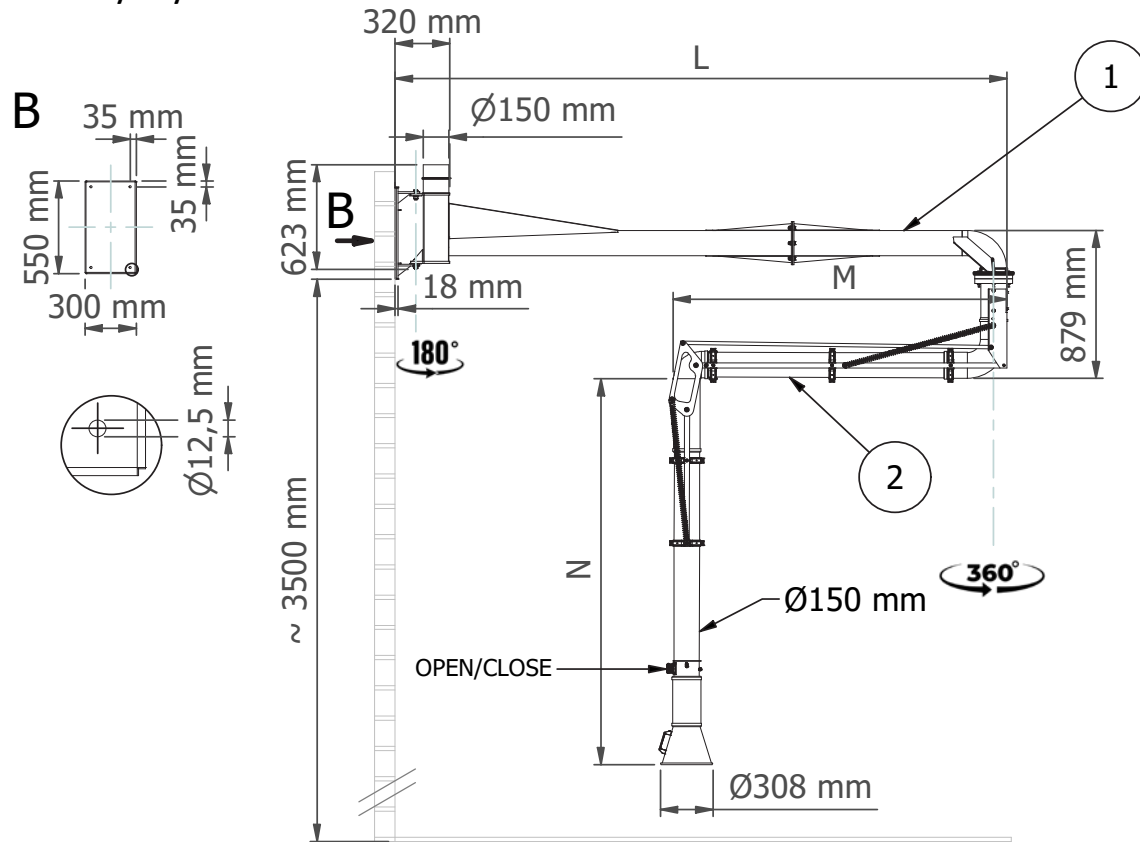

COD	Part 1	L [mm]	Part 2	M [mm]	N [mm]	L Tot [mm]	PACK			
							l [mm]	w [mm]	h [mm]	Kg
SBB6	SBAN2	2000	SB4-SM	2000	2200	6200	2400	800	1100	97
SBB7	SBAN3	3000	SB4-SM	2000	2200	7200				106
SBB8	SBAN4	4000	SB4-SM	2000	2200	8200				115
SBB9	SBAN4	4000	SB5-SM	2500	2700	9200				120

THIS DRAWING IS PROPERTY OF DEA + RO & Co S.p.A. THE COMPLETE OR PARTIAL REPRODUCTION OF THIS DOCUMENT IS FORBIDDEN. THE OWNER RESERVES THE RIGHT TO UPDATE, MODIFY OR AMEND ANY SPECIFICATION WITHOUT PRIOR NOTICE.

# ZGS150SRPNV

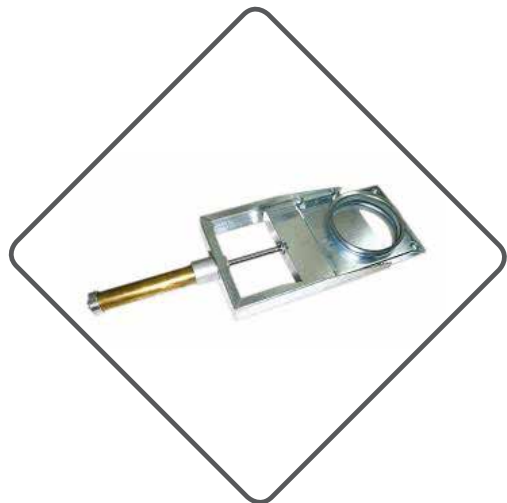

 Serranda elettropneumatica a ghigliottina per la chiusura stagna dell'aspirazione, andando ad escludere il braccio in caso non sia utilizzato. Da usare con l'apposito quadro di comando

 Electropneumatic guillotine damper for airtight closure of the extraction system, isolating the arm when not in use. To be used with the appropriate control panel.

 Clapet guillotine électropneumatique pour la fermeture étanche de l'aspiration, excluant le bras lorsqu'il n'est pas utilisé. À utiliser avec le tableau de commande approprié.

 Elektropneumatischer Guillotinenklappe für die luftdichte Absperrung der Absaugung, die den Arm bei Nichtgebrauch ausschließt. Zur Verwendung mit dem entsprechenden Steuerpult.

 Compuerta guillotina electropneumática para el cierre hermético de la extracción, excluyendo el brazo cuando no se utiliza. Para usar con el cuadro eléctrico correspondiente.

CODE	Ø
<b>ZGS150SRPNV</b>	150 MM
<b>ZGS160SRPNV</b>	160 MM
<b>ZGS200SRPNV</b>	200 MM
<b>ZGS250SRPNV</b>	250 MM

# SB-SER160MOT-QE



 Quadro elettrico di comando della serranda elettropneumatica prendendo il segnale da un interruttore esterno (non incluso)

 Electric control panel for the electro-pneumatic damper, receiving the signal from an external switch (not included).

 Tableau électrique de commande de la clapet électropneumatique, recevant le signal d'un interrupteur externe (non inclus).

 Elektrisches Steuerpult für die elektropneumatische Klappe, das das Signal von einem externen Schalter (nicht enthalten) empfängt.

 Cuadro eléctrico de control de la compuerta electropneumática, que recibe la señal de un interruptor externo (no incluido).

CODE	dim.	230V	HZ
<b>SB-SER160MOT-QE</b>	260 X 220 X H 90 mm	✓	50

# SBKL



 Kit di illuminazione per cappa aspirante, completo di interruttore per l'accensione e lo spegnimento dell'aspiratore a inserire sulla cappa del braccio SB. prodotto completo di trasformatore e cablaggi.

 Lighting kit for the suction hood, complete with a switch for turning the extractor on and off, to be installed on the hood of the SB arm. The product includes transformer and wiring.

 Kit d'éclairage pour la hotte d'aspiration, complet avec interrupteur pour l'allumage et l'extinction de l'aspirateur, à installer sur la hotte du bras SB. Produit fourni avec transformateur et câblage.

 Beleuchtungskit für die Absaughaube, komplett mit Schalter zum Ein- und Ausschalten des Absaugers, zur Montage an der Haube des SB-Arms. Das Produkt wird mit Transformator und Verkabelung geliefert.

 . Kit de iluminación para la campana de aspiración, completo con interruptor para encender y apagar el aspirador, para instalar en la campana del brazo SB. Producto completo con transformador y cableado.

CODE	V	W
<b>SBKL</b>	12	50

# SB-SM150

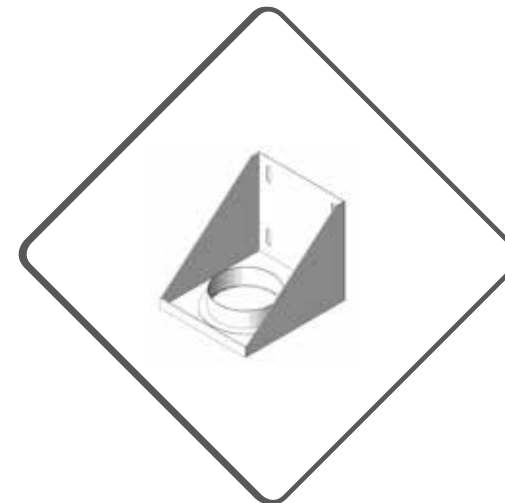

 Mensola a parete per supporto braccio SB con manicotto al diam. di 150 mm

 Wall bracket for supporting the SB arm with a sleeve of 150mm diameter.

 Équerre murale de support pour bras SB avec manchon de diamètre 150 mm.

 Wandkonsole zur Unterstützung des SB-Arms mit einer Muffe von 150mm Durchmesser.

 Soporte mural para el brazo SB con manguito de 150mm de diámetro.

CODE	dim.	Ø
<b>SB-SM150</b>	250 x 250 x H 250 mm	150 mm

# SBA



 Braccio articolato Ø 150 mm autoportante con mensola a parete, parallelogramma esterno di supporto, cappetta in materiale plastico e Aspiratore murale in diverse configurazioni di potenza.

 Self-supporting articulated arm Ø 150 mm with wall bracket, external support parallelogram, plastic hood, and wall-mounted fan available in different power configurations.

 Bras articulé autoportant Ø 150 mm avec équerre murale, parallélogramme de support externe, hotte en matériau plastique et aspirateur mural disponible en différentes configurations de puissance.

 Selbsttragender Gelenkarm Ø 150 mm mit Wandhalterung, externem Stützparallelogramm, Haube aus Kunststoff und wandmontiertem Ventilator in verschiedenen Leistungsvarianten.

 Brazo articulado autoportante Ø 150 mm con soporte mural, paralelogramo de soporte externo, campana de material plástico y aspirador mural disponible en varias configuraciones de potencia.

CODE	ARM	FAN
<b>SBA21</b>	SB2	GSA1
<b>SBA31</b>	SB3	GSA1
<b>SBA41</b>	SB4	GSA1
<b>SBA51</b>	SB5	GSA1
<b>SBA215</b>	SB2	GSA1.5

CODE	ARM	FAN
<b>SBA315</b>	SB3	GSA1.5
<b>SBA415</b>	SB4	GSA1.5
<b>SBA515</b>	SB5	GSA1.5
<b>SBA42</b>	SB4	GSA2
<b>SBA52</b>	SB5	GSA2



via Masaccio, 15  
42124 Reggio Emilia (RE) ITALY  
Tel. +39 0522 1545193  
vendite@worky-italy.com  
sales@worky-italy.com

www.worky-italy.com

### SBA - technical datasheet

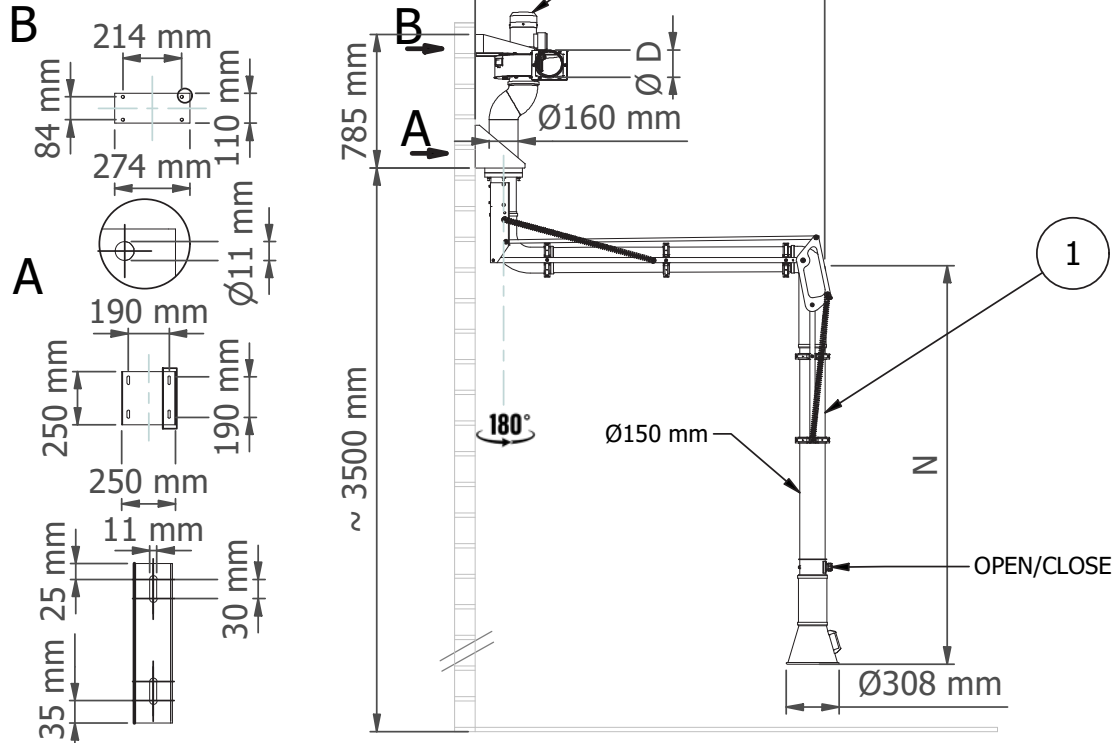



COD	Part 1	M+N [mm]	PACK			Part 2	Kw/HP	Ø D [mm]	PACK			Kg Tot
			l [mm]	w [mm]	h [mm]				l [mm]	w [mm]	h [mm]	
SBA21	SB2	2600	1750	800	550	GSA1	0,75/1	160	600	600	980	72
SBA31	SB3	3200	1750			GSA1	0,75/1					75
SBA41	SB4	4200	2400			GSA1	0,75/1					78
SBA51	SB5	5200	2600			GSA1	0,75/1					81
SBA215	SB2	2600	1750			GSA1.5	1,1/1,5					72
SBA315	SB3	3200	1750			GSA1.5	1,1/1,5	75				
SBA415	SB4	4200	2400			GSA1.5	1,1/1,5	78				
SBA515	SB5	5200	2600			GSA1.5	1,1/1,5	81				
SBA42	SB4	4200	2400			GSA2	1,5/2	87				
SBA52	SB5	5200	2600			GSA2	1,5/2	90				

THIS DRAWING IS PROPERTY OF DEA + RO & Co S.p.A. THE COMPLETE OR PARTIAL REPRODUCTION OF THIS DOCUMENT IS FORBIDDEN. THE OWNER RESERVES THE RIGHT TO UPDATE, MODIFY OR AMEND ANY SPECIFICATION WITHOUT PRIOR NOTICE.

# SBBA



 Braccio articolato montato su prolunga a bandiera tramite ralla rotante a 360° per una grande movimentazione fino ad una lunghezza massima di 9 mt totali e dotato di aspiratore murale

 Articulated arm mounted on a wall boom extension via a 360° rotating joint, allowing wide movement with a total maximum length of up to 9 meters, and equipped with a wall-mounted fan.

 Bras articulé monté sur une rallonge murale en porte-à-faux via une rotule rotative à 360°, offrant une grande amplitude de mouvement jusqu'à une longueur totale maximale de 9 mètres, équipé d'un aspirateur mural.

 Gelenkarm, montiert auf einer Wandauslegerverlängerung über ein 360° drehbares Gelenk, ermöglicht eine große Bewegungsfreiheit bei einer maximalen Gesamtlänge von bis zu 9 Metern und ist mit einem wandmontierten Ventilator ausgestattet.

 Brazo articulado montado sobre una extensión mural en voladizo mediante rótula giratoria de 360°, que permite un amplio movimiento hasta una longitud total máxima de 9 metros, equipado con aspirador mural.

CODE	ARM	FAN
<b>SBBA615</b>	SBB6	GSA1.5
<b>SBBA715</b>	SBB7	GSA1.5
<b>SBBA815</b>	SBB8	GSA1.5
<b>SBBA915</b>	SBB9	GSA1.5

CODE	ARM	FAN
<b>SBBA62</b>	SBB6	GSA2
<b>SBBA72</b>	SBB7	GSA2
<b>SBBA82</b>	SBB8	GSA2
<b>SBBA92</b>	SBB9	GSA2



via Masaccio, 15  
42124 Reggio Emilia (RE) ITALY  
Tel. +39 0522 1545193  
vendite@worky-italy.com  
sales@worky-italy.com

www.worky-italy.com

### SBBA - technical datasheet

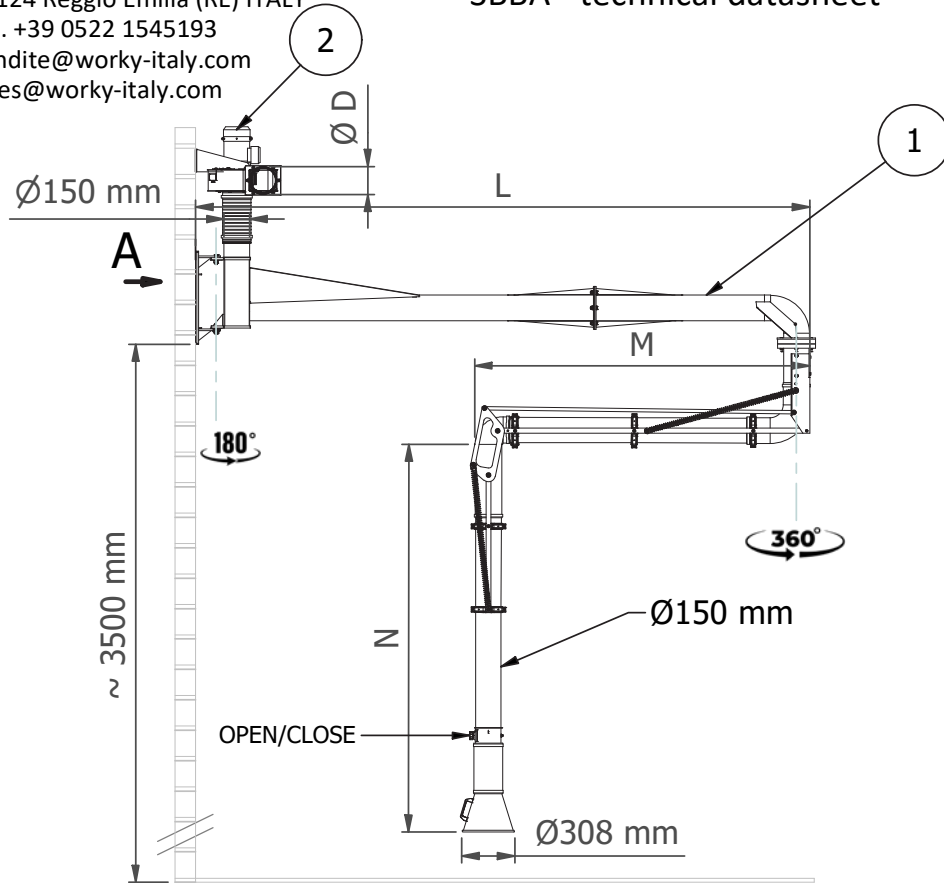
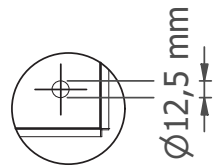
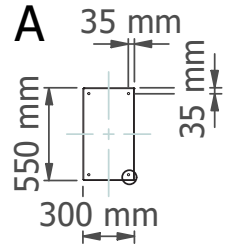



COD	Part 1	L+M+N [mm]	PACK			Part 2	Kw/HP	Ø D [mm]	PACK			Kg Tot
			l [mm]	w [mm]	h [mm]				l [mm]	w [mm]	h [mm]	
SBBA615	SBB6	6200	2400	800	1100	GSA1.5	1,1/1,5	160	600	600	980	155
SBBA715	SBB7	7200				GSA1.5	1,1/1,5					165
SBBA815	SBB8	8200				GSA1.5	1,1/1,5					175
SBBA915	SBB9	9200				GSA1.5	1,1/1,5					185
SBBA62	SBB6	6200				GSA2	1,5/2	200				170
SBBA72	SBB7	7200				GSA2	1,5/2					180
SBBA82	SBB8	8200				GSA2	1,5/2					190
SBBA92	SBB9	9200				GSA2	1,5/2					200

THIS DRAWING IS PROPERTY OF DEA + RO & Co S.p.A. THE COMPLETE OR PARTIAL REPRODUCTION OF THIS DOCUMENT IS FORBIDDEN. THE OWNER RESERVES THE RIGHT TO UPDATE, MODIFY OR AMEND ANY SPECIFICATION WITHOUT PRIOR NOTICE.

# SBF



 I bracci aspiranti snodati della serie SBF di WORKY sono un concentrato di prestazioni e flessibilità. La struttura di supporto interna e la copertura con tubo in PVC garantiscono una grande facilità di movimento con anche la possibilità di lavorare sotto-sopra. Sia in configurazione da 3 o 4 metri che con prolunga a bandiera garantiscono una grande copertura della zona da aspirare e prestazioni al top della categoria. Tutte le versioni sono disponibili con e senza serranda di chiusura manuale a tenuta stagna... una caratteristica da non sottovalutare!

 The articulated extraction arms of WORKY's SBF series are a concentrate of performance and flexibility. The internal support structure and the PVC-covered hose ensure great ease of movement, even allowing for upside-down operation. Whether in 3- or 4-meter configurations or with a boom extension, they guarantee wide coverage of the extraction area and top-class performance. All versions are available with or without a manually operated airtight shut-off damper... a feature not to be underestimated!

 Les bras d'aspiration articulés de la série SBF de WORKY sont un concentré de performance et de flexibilité. La structure de support interne et le tuyau recouvert de PVC garantissent une grande facilité de mouvement, y compris pour un fonctionnement à l'envers. Qu'ils soient en version 3 ou 4 mètres ou avec une rallonge en porte-à-faux, ils assurent une couverture étendue de la zone à aspirer et des performances au sommet de leur catégorie. Toutes les versions sont disponibles avec ou sans clapet de fermeture manuel étanche... une caractéristique à ne pas sous-estimer !

 Die gelenkigen Absaugarme der SBF-Serie von WORKY vereinen Leistung und Flexibilität in höchstem Maße. Die innere Trägerstruktur und der mit PVC ummantelte Schlauch sorgen für eine besonders einfache Handhabung – sogar für Überkopf-Arbeiten. Sowohl in der 3- oder 4-Meter-Ausführung als auch mit Schwenkausleger bieten sie eine hervorragende Abdeckung des Absaugbereichs und Spitzenleistungen in ihrer Kategorie. Alle Versionen sind mit oder ohne manuell bedienbare, luftdichte Absperrklappe erhältlich... ein nicht zu unterschätzendes Merkmal!

 Los brazos de aspiración articulados de la serie SBF de WORKY son un concentrado de rendimiento y flexibilidad. La estructura interna de soporte y el tubo recubierto de PVC garantizan una gran facilidad de movimiento, incluso permitiendo trabajar al revés. Ya sea en versiones de 3 o 4 metros o con extensión a bandera, aseguran una amplia cobertura del área de aspiración y un rendimiento de primera categoría. Todas las versiones están disponibles con o sin compuerta de cierre manual hermética... ¡una característica que no debe subestimarse!



# SBF

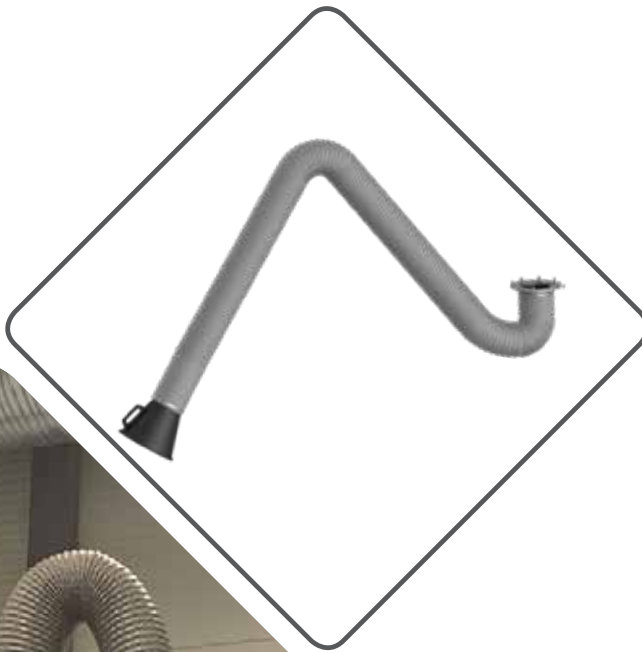

 Braccio articolato coperto da tubo flessibile diam. 160 mm con cappetta metallica. Disponibile sia nella versione da 3 che da 4 metri, da completare con il supporto che meglio si adatta all'applicazione.

 Articulated arm covered with flexible hose, Ø160 mm, with metal hood. Available in both 3- and 4-meter versions, to be completed with the support that best suits the application.

 Bras articulé recouvert d'un tuyau flexible Ø160 mm avec capot métallique. Disponible en version 3 ou 4 mètres, à compléter avec le support le plus adapté à l'application.

 Gelenkarm mit flexiblem Schlauch DN160 mm und Metallhaube. Erhältlich in 3- und 4-Meter-Ausführungen, zu ergänzen mit der am besten geeigneten Halterung für die jeweilige Anwendung.

 Brazo articulado cubierto con tubo flexible de Ø160 mm con capucha metálica. Disponible en versiones de 3 y 4 metros, para completar con el soporte que mejor se adapta a la aplicación.

CODE	L.	VALV.	DIAM.	CAP.
<b>SBF160-3</b>	3 M	-	160 mm	metal
<b>SBF160-4</b>	4 M	-	160 mm	metal





via Masaccio, 15  
 42124 Reggio Emilia (RE) ITALY  
 Tel. +39 0522 1545193  
 vendite@worky-italy.com  
 sales@worky-italy.com

www.worky-italy.com

### SBF160-3 - technical datasheet

#### OPTIONALS:



WB

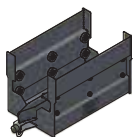

GSCB

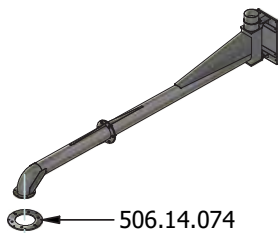

SBAN

506.14.074

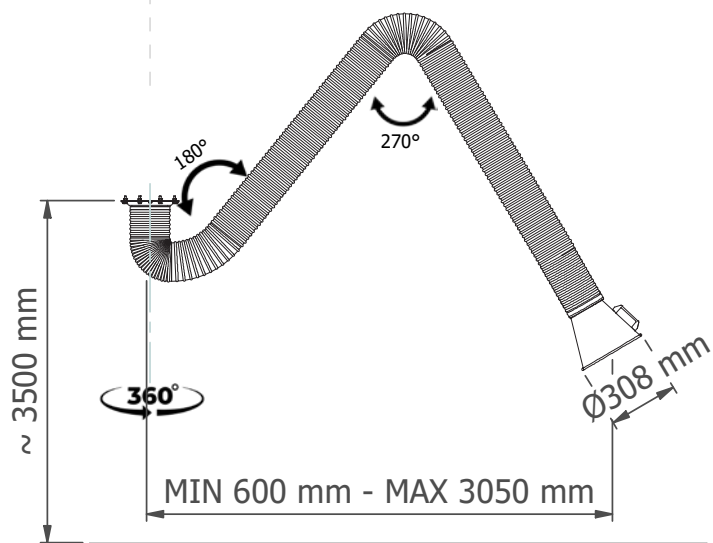

COD	L [mm]	Ø [mm]	VALV	PACK			
				l [mm]	w [mm]	h [mm]	Kg
SBF160-3	3050	160	X	172	84	50	35

THIS DRAWING IS PROPERTY OF DEA + RO & Co S.p.A. THE COMPLETE OR PARTIAL REPRODUCTION OF THIS DOCUMENT IS FORBIDDEN. THE OWNER RESERVES THE RIGHT TO UPDATE, MODIFY OR AMEND ANY SPECIFICATION WITHOUT PRIOR NOTICE.

# SBF-V



 Braccio articolato coperto da tubo flessibile diam. 160 mm con cappetta metallica e serranda manuale a tenuta stagna. Disponibile sia nella versione da 3 che da 4 metri, da completare con il supporto corretto.

 Articulated arm covered with flexible hose, Ø160 mm, with metal hood and airtight manual shut-off damper. Available in both 3- and 4-meter versions, to be completed with the appropriate support.

 Bras articulé recouvert d'un tuyau flexible Ø160 mm avec capot métallique et clapet de fermeture manuel étanche. Disponible en version 3 ou 4 mètres, à compléter avec le support approprié.

 Gelenkarm mit flexiblem Schlauch DN160 mm, Metallhaube und luftdichter manueller Absperrklappe. Erhältlich in 3- und 4-Meter-Ausführungen, zu ergänzen mit der passenden Halterung.

 Brazo articulado cubierto con tubo flexible de Ø160 mm con campana metálica y compuerta de cierre manual hermética. Disponible en versiones de 3 y 4 metros, para completar con el soporte adecuado.

CODE	L.	VALV.	DIAM.	CAP.
<b>SBF160-3V</b>	3,5 M	√	160 mm	metal
<b>SBF160-4V</b>	4,5 M	√	160 mm	metal



via Masaccio, 15  
 42124 Reggio Emilia (RE) ITALY  
 Tel. +39 0522 1545193  
 vendite@worky-italy.com  
 sales@worky-italy.com

www.worky-italy.com

### SBF160-4V - technical datasheet

#### OPTIONALS:



WB

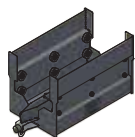

GSCB

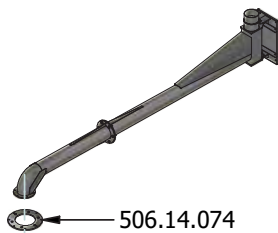

SBAN

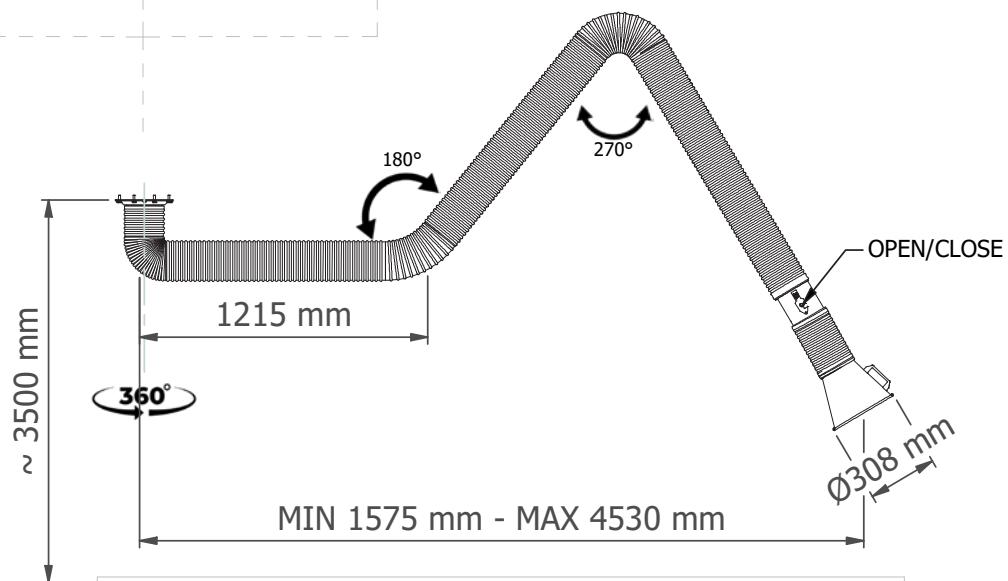
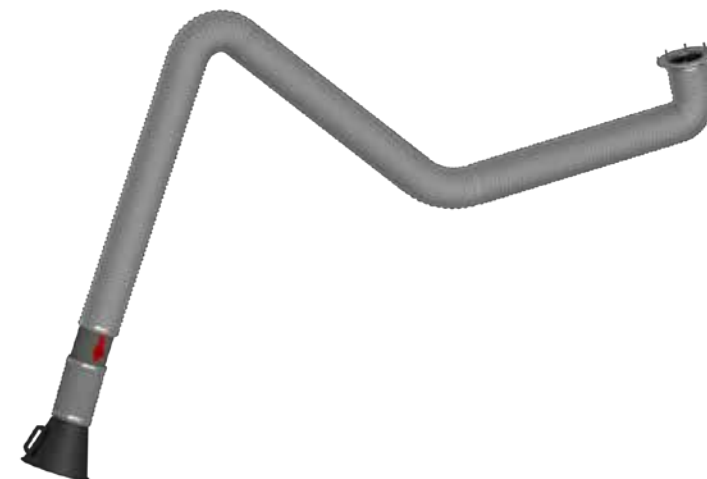



COD	L [mm]	$\varnothing$ [mm]	VALV	PACK			
				l [mm]	w [mm]	h [mm]	Kg
SBF160-4V	4530	160	✓	172	172	84	50

THIS DRAWING IS PROPERTY OF DEA + RO & Co S.p.A. THE COMPLETE OR PARTIAL REPRODUCTION OF THIS DOCUMENT IS FORBIDDEN. THE OWNER RESERVES THE RIGHT TO UPDATE, MODIFY OR AMEND ANY SPECIFICATION WITHOUT PRIOR NOTICE.

# SBFA



 Braccio articolato coperto da tubo flessibile diam. 160 mm con cappetta metallica. Disponibile sia nella versione da 3 che da 4 metri e completo di aspiratore murale in varie configurazioni di potenza.

 Articulated arm covered with flexible hose, Ø160 mm, with metal hood. Available in both 3- and 4-meter versions and equipped with a wall-mounted fan in various power configurations.

 Bras articulé recouvert d'un tuyau flexible Ø160 mm avec capot métallique. Disponible en version 3 ou 4 mètres et équipé d'un aspirateur mural en différentes configurations de puissance.

 Gelenkarm mit flexiblem Schlauch Ø160 mm und Metallhaube. Erhältlich in 3- und 4-Meter-Ausführungen und ausgestattet mit einem wandmontierten Ventilator in verschiedenen Leistungsstufen.

 Brazo articulado cubierto con tubo flexible de Ø160 mm con capucha metálica. Disponible en versiones de 3 y 4 metros y equipado con ventilador mural en varias configuraciones de potencia.

CODE	ARM	FAN
<b>SBFA315</b>	SBF160-3	GSA1.5
<b>SBFA41</b>	SBF160-4	GSA1
<b>SBFA415</b>	SBF160-4	GSA1.5
<b>SBFA42</b>	SBF160-4	GSA2
<b>SBFA43</b>	SBF160-4	GSA3



via Masaccio, 15  
42124 Reggio Emilia (RE) ITALY  
Tel. +39 0522 1545193  
vendite@worky-italy.com  
sales@worky-italy.com

### SBFA - technical datasheet

www.worky-italy.com

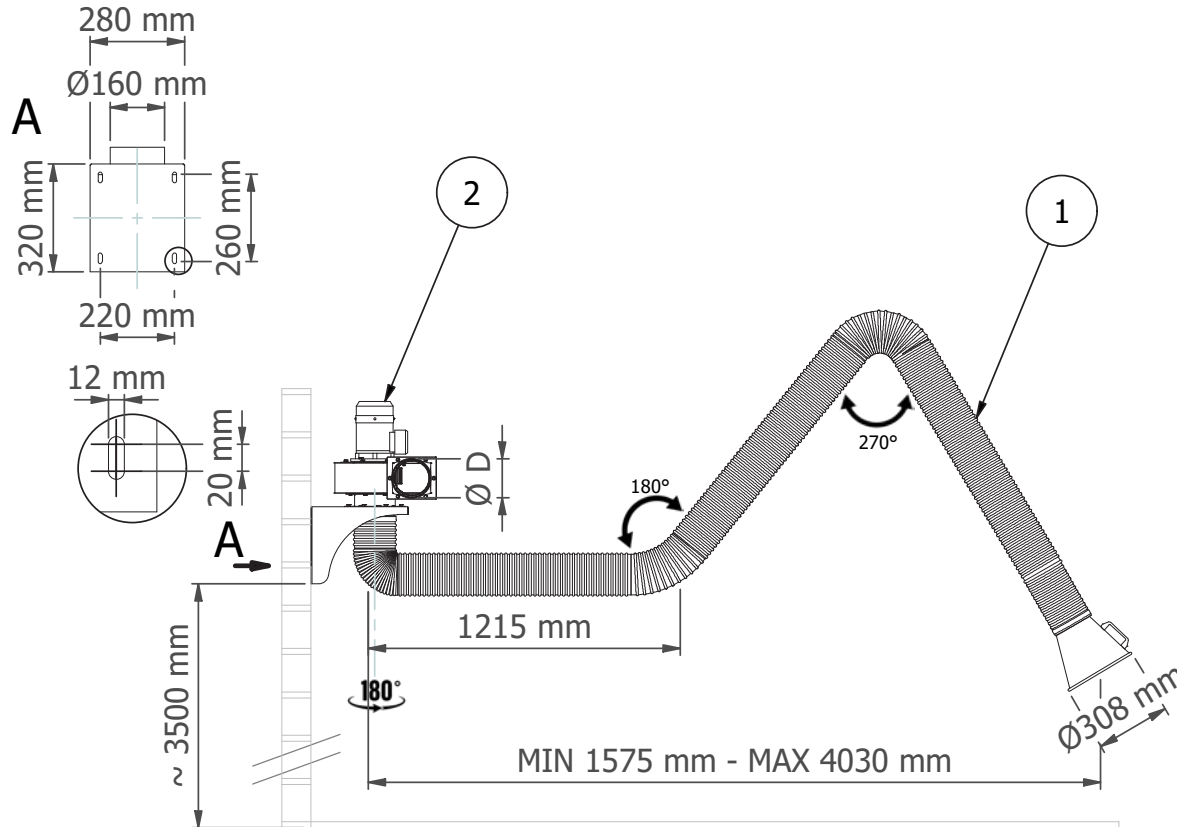



COD	Part 1	L [mm]	PACK			Part 2	Kw/HP	Ø D [mm]	PACK			Kg Tot
			l [mm]	w [mm]	h [mm]				l [mm]	w [mm]	h [mm]	
SBFA41	SBF160-4	4030	172	172	84	GSA1	0,75/1	160	600	600	980	70
SBFA415						GSA1.5	1,1/1,5	160				73
SBFA42						GSA2	1,5/2	200				82
SBFA43						GSA3	2,2/3	200				85

THIS DRAWING IS PROPERTY OF DEA + RO & Co S.p.A. THE COMPLETE OR PARTIAL REPRODUCTION OF THIS DOCUMENT IS FORBIDDEN. THE OWNER RESERVES THE RIGHT TO UPDATE, MODIFY OR AMEND ANY SPECIFICATION WITHOUT PRIOR NOTICE.

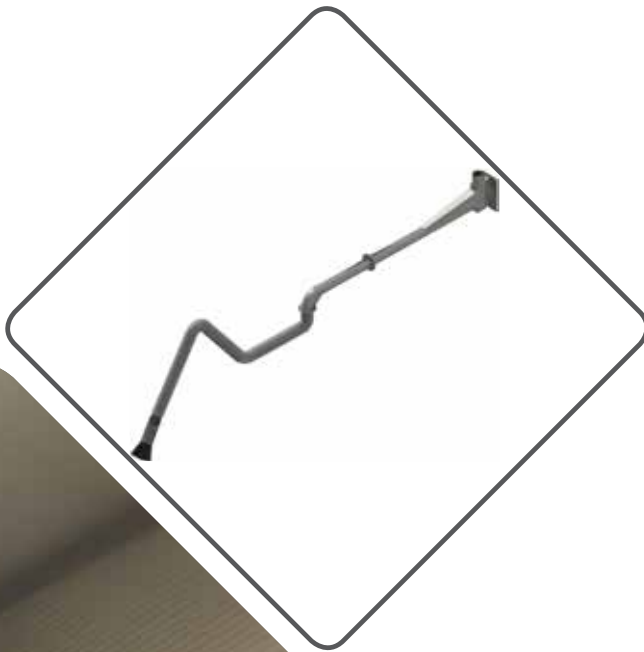
# SBBF-V



 Braccio articolato coperto da tubo flessibile diam. 160 mm con cappetta metallica montato su prolunga a bandiera. Disponibile sia nella versione con serranda a tenuta stagna che senza.

 Articulated arm covered with flexible hose, Ø160 mm, with metal hood, mounted on a boom extension. Available in both versions: with airtight shut-off damper or without.

 Bras articulé recouvert d'un tuyau flexible Ø160 mm avec capot métallique, monté sur une rallonge en porte-à-faux. Disponible en version avec clapet de fermeture étanche ou sans.

 Gelenkarm mit flexiblem Schlauch Ø160 mm und Metallhaube, montiert an einem Schwenkausleger. Erhältlich mit oder ohne luftdichter Absperrklappe.

 Brazo articulado cubierto con tubo flexible de Ø160 mm con capucha metálica, montado sobre una prolongación en voladizo. Disponible en versión con o sin compuerta de cierre hermética.

CODE	L.	VALV.	DIAM.
<b>SBBF6</b>	6,0 M	-	160 mm
<b>SBBF7</b>	7,0 M	-	160 mm
<b>SBBF8</b>	8,0 M	-	160 mm

CODE	L.	VALV.	DIAM.
<b>SBBFV6</b>	6,5 M	✓	160 mm
<b>SBBFV7</b>	7,5 M	✓	160 mm
<b>SBBFV8</b>	8,5 M	✓	160 mm



via Masaccio, 15  
42124 Reggio Emilia (RE) ITALY  
Tel. +39 0522 1545193  
vendite@worky-italy.com  
sales@worky-italy.com

www.worky-italy.com

### SBBFV - technical datasheet

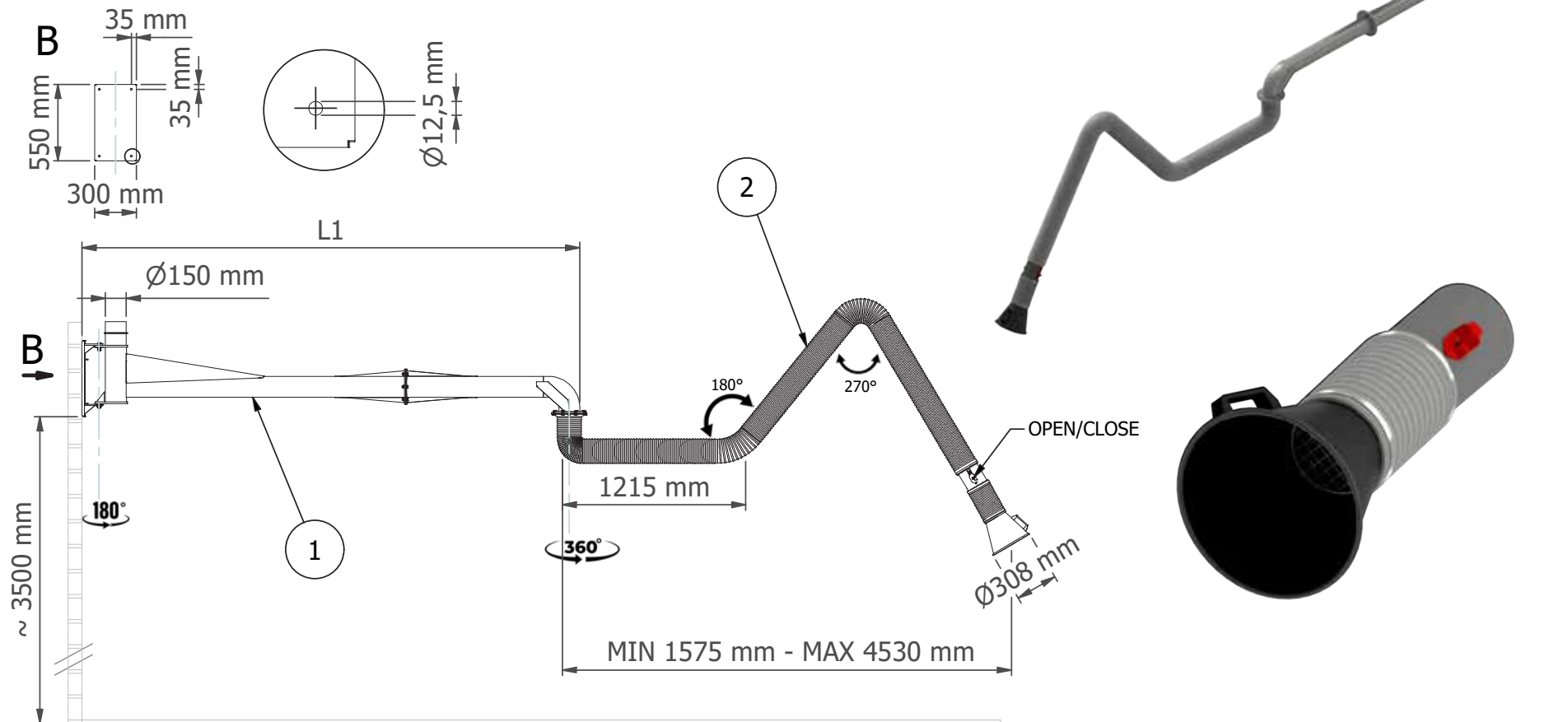

COD	Part 1	L1 [mm]	PACK			Part 2	L2 [mm]	Ø [mm]	VALV	PACK			L Tot [mm]	Kg Tot
			l [mm]	w [mm]	h [mm]					l [mm]	w [mm]	h [mm]		
SBBFV6	SBAN2	2000	240	80	52	SBF160-4V	4530	160	✓	172	172	84	6530	120
SBBFV7	SBAN3	3000	240	80	52	SBF160-4V	4530	160	✓				7530	134
SBBFV8	SBAN4	4000	260	80	52	SBF160-4V	4530	160	✓				8530	144

THIS DRAWING IS PROPERTY OF DEA + RO & Co S.p.A. THE COMPLETE OR PARTIAL REPRODUCTION OF THIS DOCUMENT IS FORBIDDEN. THE OWNER RESERVES THE RIGHT TO UPDATE, MODIFY OR AMEND ANY SPECIFICATION WITHOUT PRIOR NOTICE.

# SBBFA



 Aspiratore portatile per fumi di saldatura specifico per torce aspiranti o saldobrasatura. Facile da collegare, molto maneggevole e dalle ottime performance. Da completare con i relativi accessori in base all'utilizzo.

 Portable fume extractor for welding fumes specifically for suction torches or braze welding. Easy to connect, very handy and excellent performance. To be completed with the relevant accessories according to use.

 Aspirateur de fumées portable pour les fumées de soudage, spécialement pour les torches aspirantes ou le soudage à la brasure. Facile à brancher, très maniable et d'une excellente performance. A compléter avec les accessoires appropriés en fonction de l'utilisation.

 Tragbarer Absauger für Schweißbrauch, speziell für Saugbrenner oder Lötarbeiten. Einfach anzuschließen, sehr handlich und mit hervorragender Leistung. Je nach Verwendung mit dem entsprechenden Zubehör zu vervollständigen.

 Extractor portátil de humos de soldadura específico para sopletes de aspiración o soldadura fuerte. Fácil de conectar, muy manejable y de excelentes prestaciones. A completar con los accesorios pertinentes según el uso.

CODE	POWER	M <sup>3</sup> /H	CARB.
<b>STOR</b>	0,88 KW - 230V 50HZ 1PH + T	100	-
<b>STOR-C</b>	0,88 KW - 230V 50HZ 1PH + T	100	2 KG
<b>STOR-CAP50</b>	MAGNETIC HOOD Ø 50 MM	-	-
<b>GTP-50-2</b>	FLEX Ø 50 MM - 2 MT - 110°C	-	-



via Masaccio, 15  
 42124 Reggio Emilia (RE) ITALY  
 Tel. +39 0522 1545193  
 vendite@worky-italy.com  
 sales@worky-italy.com

### SBBFA - technical datasheet

www.worky-italy.com

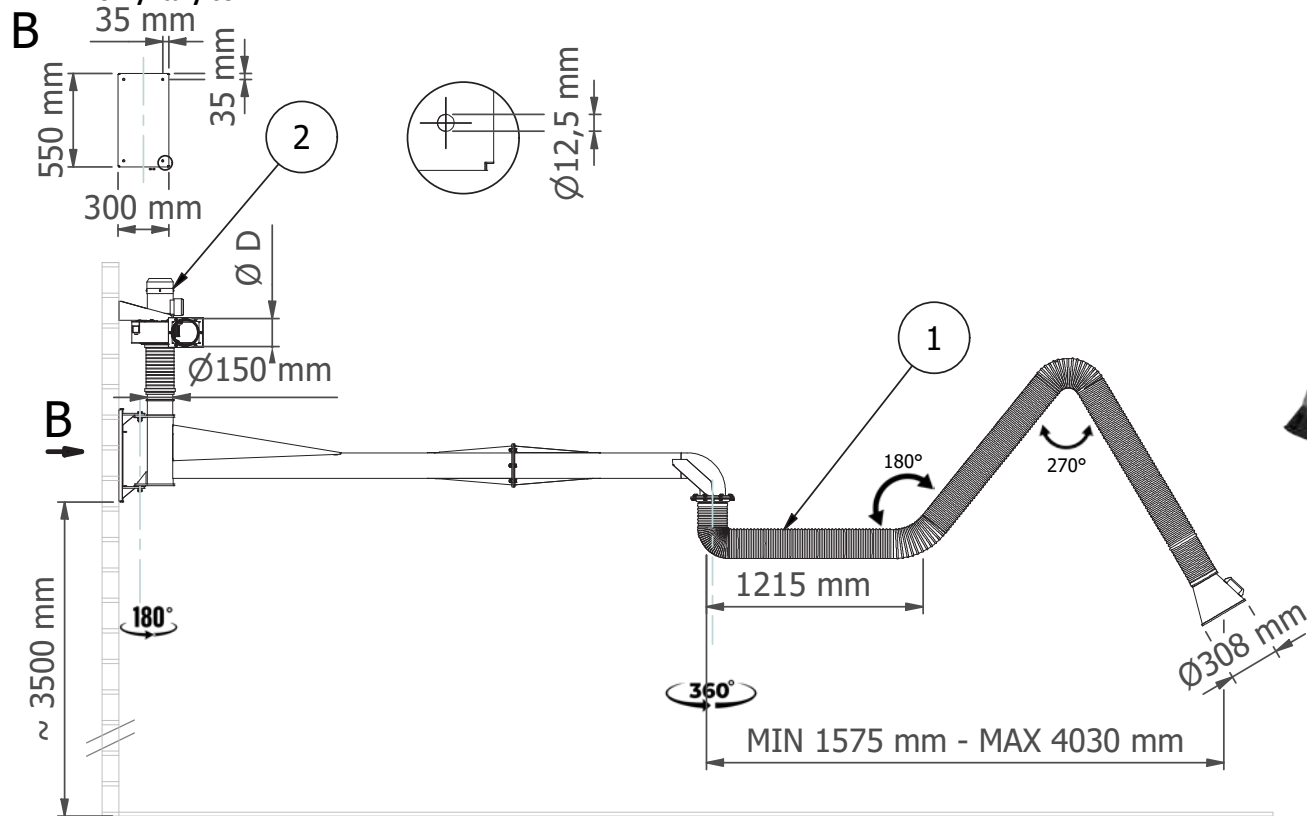



COD	Part 1	L1 [mm]	PACK			PACK			Part 2	Kw/HP	ø D [mm]	PACK			Kg Tot
			l [mm]	w [mm]	h [mm]	l [mm]	w [mm]	h [mm]				l [mm]	w [mm]	h [mm]	
SBBFA615	SBBF6	6030	240	80	52	172	172	84	GSA1.5	1,1/1,5	160	600	600	980	180
SBBFA62	SBBF6	6030	240	80	52				GSA2	1,5/2	200				195
SBBFA715	SBBF7	7030	240	80	52				GSA1.5	1,1/1,5	160				195
SBBFA72	SBBF7	7030	240	80	52				GSA2	1,5/2	200				210
SBBFA815	SBBF8	8030	260	80	52				GSA1.5	1,1/1,5	160				205
SBBFA82	SBBF8	8030	260	80	52				GSA2	1,5/2	200				220

THIS DRAWING IS PROPERTY OF DEA + RO & Co S.p.A. THE COMPLETE OR PARTIAL REPRODUCTION OF THIS DOCUMENT IS FORBIDDEN. THE OWNER RESERVES THE RIGHT TO UPDATE, MODIFY OR AMEND ANY SPECIFICATION WITHOUT PRIOR NOTICE.

# SPECIALS



 WORKY ha una gamma molto vasta di bracci per l'aspirazione dei fumi di saldatura ed alcune sono specifiche per risolvere casi particolari: braccetti murali per cabine di saldatura, bracci grandi per impieghi gravosi, bracci sottosopra per lavorare vicino alle pareti, minibracci da laboratorio... tutte queste soluzioni derivano da casi concreti che hanno trovato soluzione con prodotti specificamente studiati.

 WORKY offers a very wide range of arms for welding fume extraction, some of which are specifically designed to solve particular cases: wall-mounted arms for welding booths, large arms for heavy-duty applications, upside-down arms for working near walls, mini arms for laboratories... all these solutions come from real cases that found a solution with specially designed products.

 WORKY propose une très large gamme de bras pour l'aspiration des fumées de soudage, dont certains sont spécialement conçus pour résoudre des cas particuliers : bras muraux pour cabines de soudage, bras de grande taille pour usages intensifs, bras inversés pour travailler près des parois, mini-bras pour laboratoires... toutes ces solutions proviennent de cas concrets qui ont trouvé une réponse grâce à des produits spécifiquement étudiés.

 WORKY bietet ein sehr breites Sortiment an Absaugarme für Schweißbrauch, von denen einige speziell zur Lösung besonderer Fälle entwickelt wurden: Wandarme für Schweißkabinen, große Arme für schwere Einsätze, Überkopf-Arme zum Arbeiten in Wandnähe, Mini-Arme für Labore... all diese Lösungen stammen aus konkreten Anwendungsfällen, die mit speziell entwickelten Produkten gelöst wurden.

 WORKY cuenta con una amplia gama de brazos para la aspiración de humos de soldadura, algunos específicamente diseñados para resolver casos particulares: brazos murales para cabinas de soldadura, brazos grandes para aplicaciones exigentes, brazos invertidos para trabajar cerca de paredes, mini brazos para laboratorios... todas estas soluciones provienen de casos reales que encontraron solución con productos especialmente diseñados.



# SBMINI



 Mini braccio articolato con cappetta metallica e staffa murale, da completare con tubo flessibile GTP.

 Mini articulated arm with metal hood and wall bracket, to be completed with GTP flexible hose.

 Mini bras articulé avec capot métallique et support mural, à compléter avec un tuyau flexible GTP.

 Mini-Gelenkarm mit Metallhaube und Wandhalterung, zu vervollständigen mit GTP-Flexschlauch.

 Mini brazo articulado con capucha metálica y soporte mural, para completar con tubo flexible GTP.

CODE	Ø	L.
<b>SBMINI100-1.2</b>	100 MM	1,2 M
<b>SBMINI120-1.2</b>	120 MM	1,2 M
<b>SBMINI150-1.1</b>	150 MM	1,1 M

# SBC



 Braccio di ricambio per macchine carrellate della famiglia SMOBI (SMOBIPLUS, SMOBIMAX, SMOBIJET) da 3 mt di lunghezza totale e diametro di 150 mm con cappetta in materiale plastico, rete anti intrusione e farfalla di parzializzazione del flusso aspirato.

 Replacement arm for SMOBI family (SMOBIPLUS, SMOBIMAX, SMOBIJET) 3 m total length and 150 mm diameter with plastic hood, protection net and suction flow partialisation butterfly flap.

 Bras de remplacement pour la famille SMOBI (SMOBIPLUS, SMOBIMAX, SMOBIJET) d'une longueur totale de 3 m et d'un diamètre de 150 mm avec hotte en plastique, chiffon de protection et volet papillon de partialisation du flux d'aspiration.

 Ersatzarm für die SMOBI-Familie (SMOBIPLUS, SMOBIMAX, SMOBIJET) 3 m Gesamtlänge und 150 mm Durchmesser mit Kunststoffhaube, Schutznetz und Absaugungsteilungsklappe.

 Brazo de recambio para la familia SMOBI (SMOBIPLUS, SMOBIMAX, SMOBIJET) de 3 m de longitud total y 150 mm de diámetro con campana de plástico, red de protección y mariposa de parcialización del flujo de aspiración.

CODE	L.	Ø
<b>SBC2</b>	2 M	150 mm
<b>SBC3</b>	3 M	150 mm
<b>SBC4</b>	4 M	150 mm

# SBC200



 Braccio di ricambio per macchine carrellate (SMOBIMAX e SMOBIJET) da 3 mt di lunghezza totale e diametro di 200 mm con cappetta in metallo, rete anti intrusione e farfalla di parzializzazione del flusso aspirato.

 Replacement arm for SMOBIMAX and SMOBIJET 3 m total length and 200 mm diameter with metal hood, protection net and suction flow partialisation butterfly flap.

 Bras de remplacement pour SMOBIMAX et SMOBIJET d'une longueur totale de 3 m et d'un diamètre de 200 mm avec hotte métallique, chiffon de protection et volet papillon de partialisation du flux d'aspiration.

 Ersatzarm für SMOBIMAX und SMOBIJET 3 m Gesamtlänge und 200 mm Durchmesser mit Metallhaube, Schutznetz und Absaugungsteilungsklappe.

 Brazo de recambio para SMOBIMAX y SMOBIJET de 3 m de longitud total y 200 mm de diámetro con campana de metal, red de protección y mariposa de parcialización del flujo de aspiración.

CODE	L.	Ø
<b>SBC2003</b>	3 M	200 mm

# SMBR



 Mini braccio rigido in alluminio per configurazione murale o a banco dotato di 3 snodi e di cappetta per la captazione di fumi (tipo saldobrasatura) o polveri derivanti da lavorazioni tipiche da laboratorio.

 Mini rigid aluminium arm for wall-mounted or bench-top configuration, equipped with 3 joints and a hood for capturing fumes (e.g. from brazing) or dust generated by typical laboratory processes.

 Mini bras rigide en aluminium pour une configuration murale ou sur établi, équipé de 3 articulations et d'un capot pour la captation des fumées (par exemple de brasage) ou des poussières générées par les opérations typiques de laboratoire.

 Mini-Starres Aluminiumarm für Wand- oder Tischmontage, ausgestattet mit 3 Gelenken und einer Haube zur Erfassung von Rauch (z.B. beim Hartlöten) oder Staub aus typischen Laborarbeiten.

 Mini brazo rígido de aluminio para instalación mural o sobre banco, equipado con 3 articulaciones y una campana para la captación de humos (como los de soldadura fuerte) o polvos generados por procesos típicos de laboratorio.

CODE	L.	Ø
<b>SMBR75-1730</b>	1730 MM	75 mm

# CAT. ACCESS.

# CAT. VENTILAT.

# CAT. FILTRI



SCAN THE QR CODE  
DOWNLOAD THE  
CATALOGUE



SCAN THE QR CODE  
DOWNLOAD THE  
CATALOGUE



SCAN THE QR CODE  
DOWNLOAD THE  
CATALOGUE



**WORRY**®

# WORKY®

## WORKY Headquarters and Production

Via Masaccio, 15 - Z.I. Mancasale  
42124 - REGGIO EMILIA (RE) ITALY

Tel. **+39-0522-1545193**

Fax. **+39-0522-1546451**

[sales@worky-italy.com](mailto:sales@worky-italy.com)

[vendite@worky-italy.com](mailto:vendite@worky-italy.com)

[www.worky-italy.com](http://www.worky-italy.com)

## WORKY North America Inc.

112 South Tryon Street  
Suite 1130 Charlotte, North Carolina  
28284 USA

Tel **+1 (305) 705 5017**

[www.deaworkyna.com](http://www.deaworkyna.com)



**Inquadra il QR Code e scopri il nostro sito!**  
**Frame the QR Code to discover our website!**



**Seguici su / Follow us on:**



QUALITY CERTIFIED ISO 9001:2015