



WORKY®

NOZZLES

BOCCHETTE

ENTONNOIRS

TRICHTER

BOQUERELES



GRN
Pag. 6



GON
Pag. 24



GRTN
Pag. 34



GMN
Pag. 44



GYNMAG
Pag. 55



GMNT-HT
Pag. 76



GRN

 La bocchetta in gomma modello GRN (Gas Rubber Nozzle) presenta una bocca di aspirazione di 160 mm di diametro è stata sviluppata da WORKY per adattarsi alle molteplici conformazioni dei tubi di scarico più comuni sul mercato. Il prodotto è stato concepito per essere configurato con clip di fissaggio, pinza grip, tappo a membrana, maniglia di movimentazione e curveta a 30°.

Tutte le versioni presentano l'apertura per l'inserimento della sonda per la prova opacimetrica e un tronchetto con serranda di chiusura a tenuta stagna completa di griglia contro l'ingresso di corpi estranei.

 The GRN (Gas Rubber Nozzle) rubber nozzle has a suction intake of 160 mm diameter and was developed by WORKY to adapt to the many conformations of the most common exhaust pipes on the market. The product is designed to be configured with fixing clips, grip clamp, membrane cap, grabbing handle and 30° bend.

All versions have opacimeter probe opening and a coupling with watertight sealing damper complete with protection grid against foreign bodies.



 L'entonnoir en caoutchouc GRN (Gas Rubber Nozzle) a une aspiration de 160 mm de diamètre et a été développé par WORKY pour s'adapter aux nombreuses conformations des pots d'échappement les plus courants sur le marché. Le produit est conçu pour être configuré avec des clips de fixation, une pince étau, un bouchon à membrane, une poignée de saisie et une courbe de 30°. Toutes les versions ont une prise pour la sonde de l'opacimètre et un manchon avec avec registre étanche complet avec grille de protection contre les corps étrangers.

 Die GRN (Gas Rubber Nozzle) Gummitrichter hat eine Saugöffnung von 160 mm Durchmesser und wurde von WORKY entwickelt, um sich an die vielen Konformationen der gängigsten Abgasrohre im Markt anzupassen. Das Produkt ist so konzipiert, dass es mit Befestigungsclips, Klemmzange, Membrankappe, Greifgriff und 30° Biegung konfiguriert werden kann. Alle Ausführungen haben AU-Sonde Öffnung und eine Kupplung mit wasserdichtem Dämpfer komplett mit Schutzgitter gegen Fremdenkörpern.

 El boquerel en goma GRN (Gas Rubber Nozzle) tiene una entrada de aspiración de 160 mm de diámetro y fue desarrollada por WORKY para adaptarse a las numerosas conformaciones de los tubos de escape más comunes del mercado. El producto está diseñado para ser configurado con clips de fijación, mordaza, tapón de membrana, manija de agarre y curva de 30°. Todas las versiones tienen ingreso para sonda del opacímetro y un manguito con cierre hermético integrado completo de rejilla anti-intrusión.

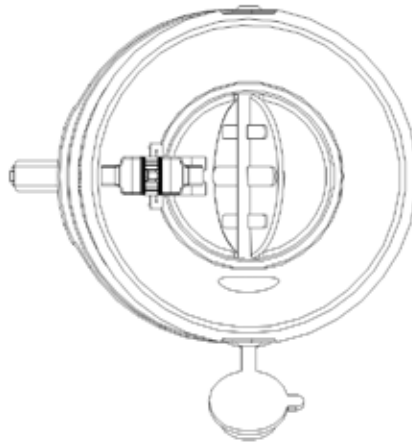
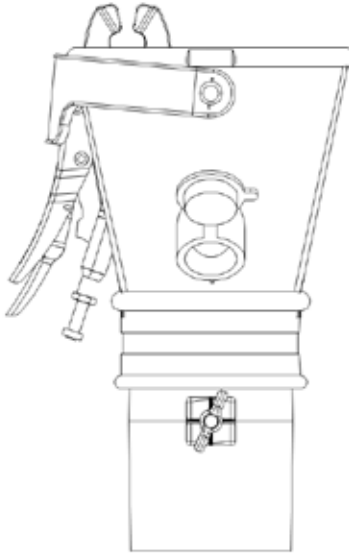



GRN



 Bocchetta in gomma con apertura di 160 mm, manicotto di collegamento dotato di serranda manuale a tenuta stagna, ingresso sonda per la prova opacimetrica.

 Rubber nozzle with 160 mm suction diameter, hose coupling with fully tight manual closing valve and probe intake for C.O. test.

 Entonnoir en caoutchouc avec bouche d'aspiration de 160 mm de diamètre, manchon avec registre étanche, grille anti-intrusion et entrée pour la sonde de l'opacimètre.

 Gummitrichter mit Saugöffnung DN 160 mm x 105 mm, Schlauch-Kupplung mit Integriertem Absperrklappe, Schutznetz und Öffnung für AU Sonde.

 Boquerel en goma con boca de aspiración de 160 mm completo de manguito con tapa de cierre hermética, rejilla anti-intrusión y toma para sonda.

cod.	IN	OUT	valv.	notes
GRN-16075	160 mm	ø 75 mm	√	-
GRN-160100	160 mm	ø 100 mm	√	-
GRN-160125	160 mm	ø 125 mm	√	-



via Masaccio, 15
 42124 Reggio Emilia (RE) ITALY
 Tel. +39 0522 1545193
 vendite@worky-italy.com
 sales@worky-italy.com

www.worky-italy.com

GRN - technical datasheet

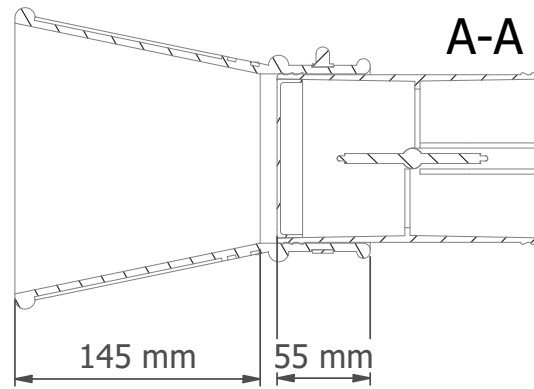
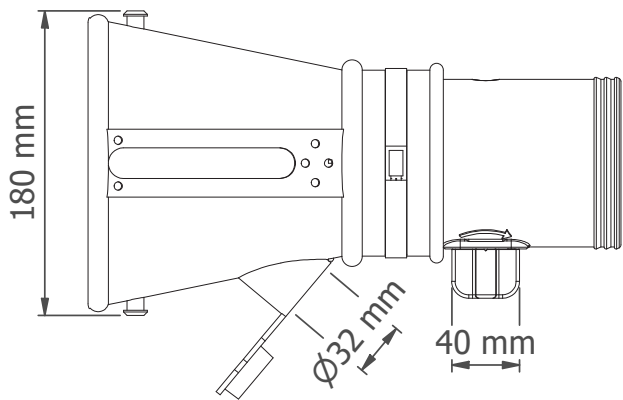
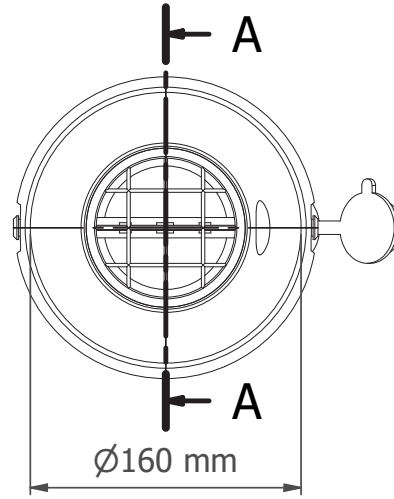
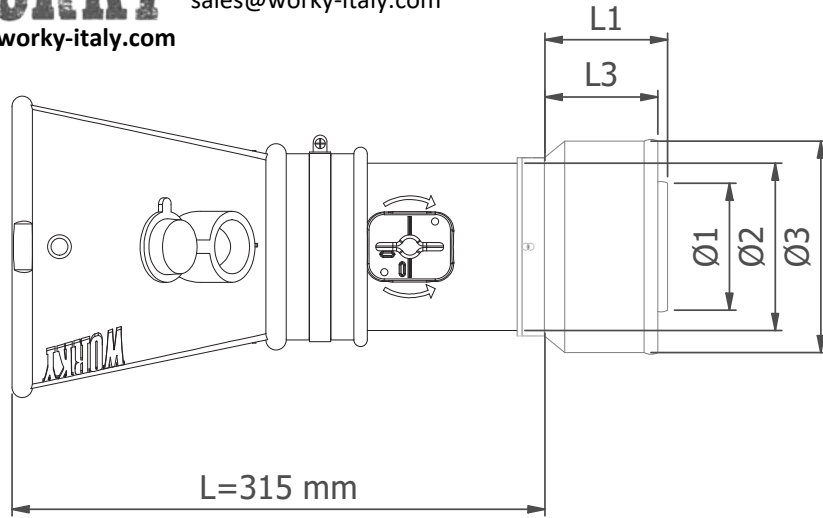

	COD	L [mm]	LRID [mm]	LTOT [mm]	Ø [mm]	PACK			Kg Tot
						l [mm]	w [mm]	h [mm]	
1	GRN-16075	315	72	387	75	400	300	220	2
2	GRN-160100	315	-	315	100	400	300	220	2
3	GRN-160125	315	67	382	125	400	300	220	2

THIS DRAWING IS PROPERTY OF DEA + RO & Co S.p.A. THE COMPLETE OR PARTIAL REPRODUCTION OF THIS DOCUMENT IS FORBIDDEN. THE OWNER RESERVES THE RIGHT TO UPDATE, MODIFY OR AMEND ANY SPECIFICATION WITHOUT PRIOR NOTICE.

Rev.00

1/1
 05/06/2024

GRNT



 Bocchetta in gomma con apertura di 160 mm, tappo a membrana, manicotto di collegamento dotato di serranda manuale a tenuta stagna, ingresso sonda per la prova opacimetrica.

 Rubber nozzle with 160 mm suction diameter, rubber closing membrane, hose coupling with fully tight manual closing valve and probe intake for C.O. test.

 Entonnoir en caoutchouc avec bouche d'aspiration de 160 mm de diamètre, bouchon en caoutchouc, manchon avec registre étanche, grille anti-intrusion et entrée pour la sonde de l'opacimètre.

 Gummitrichter mit Saugöffnung DN 160 mm, Gummikappe, Schlauch-Kupplung mit Integriertem Absperrklappe, Schutznetz und Öffnung für AU Sonde.

 Boquerel en goma con boca de aspiración de 160 mm completo de tapón en goma, manguito con tapa de cierre hermética, rejilla anti-intrusión y toma para sonda.

cod.	IN	OUT	valv.	notes
GRNT-16075	160 mm	ø 75 mm	√	-
GRNT-160100	160 mm	ø 100 mm	√	-
GRNT-160125	160 mm	ø 125 mm	√	-



via Masaccio, 15
42124 Reggio Emilia (RE) ITALY
Tel. +39 0522 1545193
vendite@worky-italy.com
sales@worky-italy.com

www.worky-italy.com

GRNT - technical datasheet

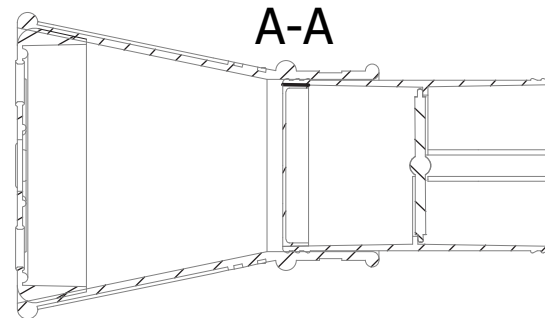
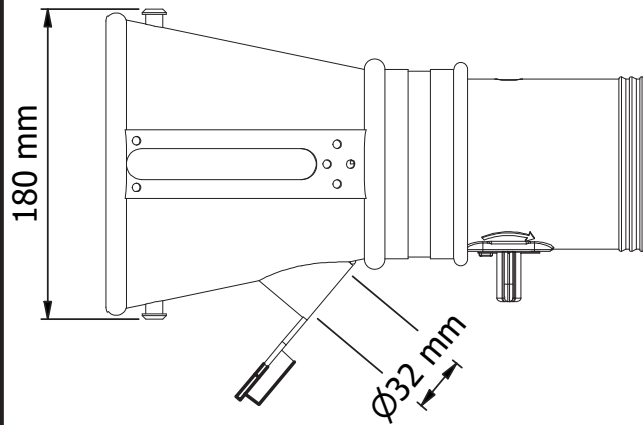
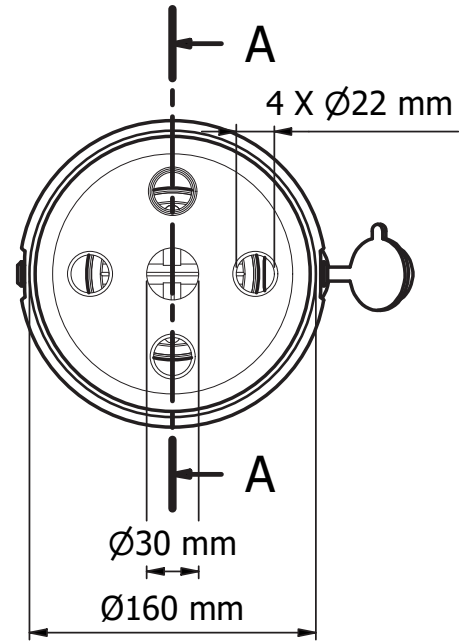
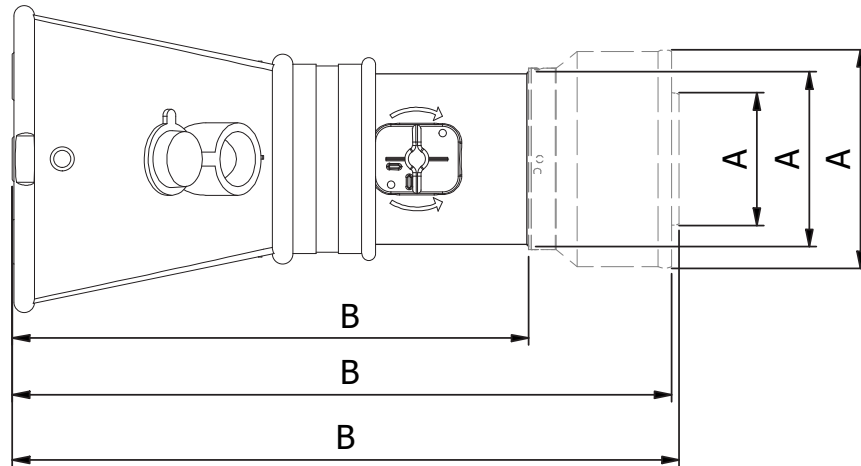

mm x x H
Kg 1.5

GRNT	A Ø	B
GRNT-16075	75mm	397mm
GRNT-160100	100mm	309mm
GRNT-160125	125mm	392mm

Rev.00

23/06/2023

THIS DRAWING IS PROPERTY OF DEA + RO & Co S.p.A. THE COMPLETE OR PARTIAL REPRODUCTION OF THIS DOCUMENT IS FORBIDDEN. THE OWNER RESERVES THE RIGHT TO UPDATE, MODIFY OR AMEND ANY SPECIFICATION WITHOUT PRIOR NOTICE.

GRNK



 Bocchetta in gomma con apertura di 160 mm, clip di fissaggio con estremità gommata, manicotto di collegamento dotato di serranda a tenuta stagna, ingresso sonda per la prova opacimetrica.

 Rubber nozzle with 160 mm suction diameter, fixing clip with vulcanized rubber end, hose coupling with fully tight closing valve and probe intake for C.O. test.

 Entonnoir en caoutchouc avec bouche d'aspiration de 160 mm de diamètre, clip de fixation avec terminal en caoutchouc, manchon avec registre étanche, grille anti-intrusion et entrée pour la sonde de l'opacimètre.

 Gummitrichter mit Saugöffnung DN 160 mm, Stahlfixierung-Klemmvorrichtung mit vulkanisiertem Gummischutz, Schlauch-Kupplung mit integriertem Absperrklappe, Schutznetz und Öffnung für AU Sonde.

 Boquerel en goma con boca de aspiración de 160 mm completo de clip de fijación vulcanizada en goma, manguito con tapa de cierre hermética, rejilla anti-intrusión y toma para sonda.

cod.	IN	OUT	valv.	notes
GRNK-16075	160 mm	ø 75 mm	√	CLIP
GRNK-160100	160 mm	ø 100 mm	√	CLIP
GRNK-160125	160 mm	ø 125 mm	√	CLIP



via Masaccio, 15
42124 Reggio Emilia (RE) ITALY
Tel. +39 0522 1545193
vendite@worky-italy.com
sales@worky-italy.com

www.worky-italy.com

GRNK - technical datasheet

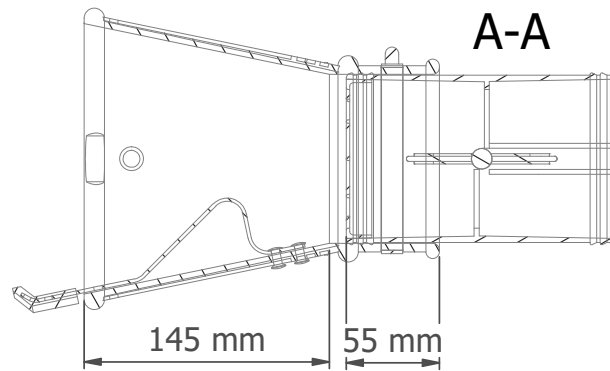
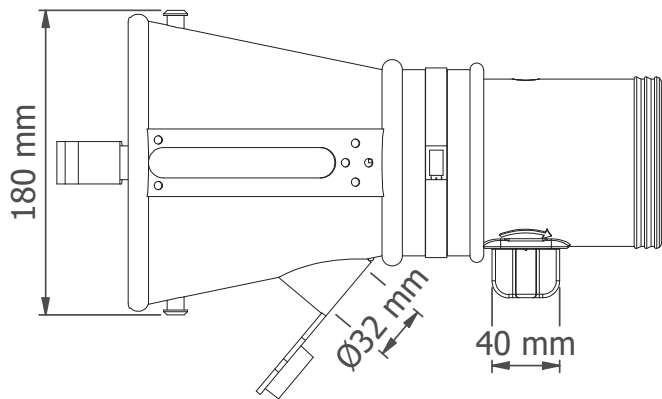
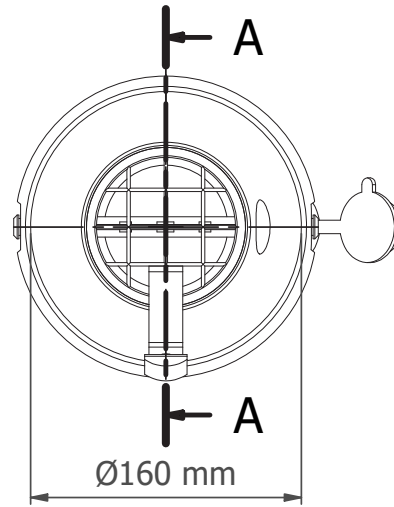
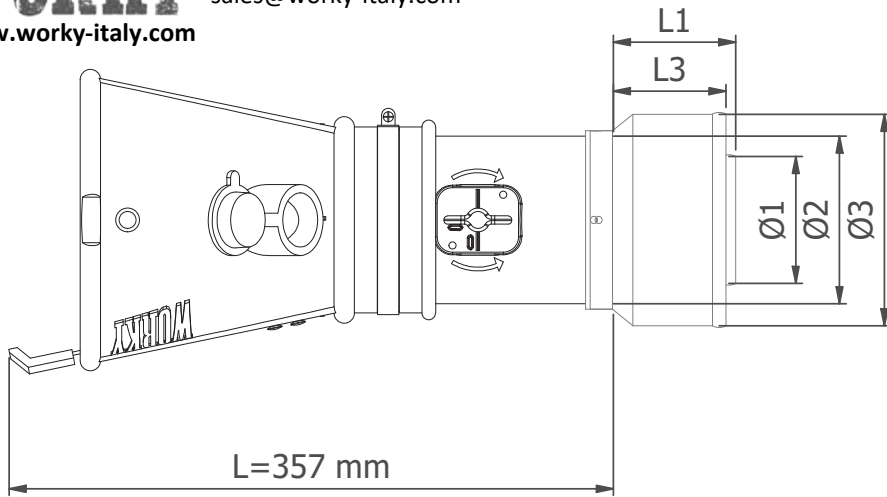

	COD	L [mm]	LRID [mm]	LTOT [mm]	Ø [mm]	PACK			Kg Tot
						l [mm]	w [mm]	h [mm]	
1	GRNK-16075	357	72	429	75	400	300	220	2
2	GRNK-160100	357	-	357	100	400	300	220	2
3	GRNK-160125	357	67	424	125	400	300	220	2

THIS DRAWING IS PROPERTY OF DEA + RO & Co S.p.A. THE COMPLETE OR PARTIAL REPRODUCTION OF THIS DOCUMENT IS FORBIDDEN. THE OWNER RESERVES THE RIGHT TO UPDATE, MODIFY OR AMEND ANY SPECIFICATION WITHOUT PRIOR NOTICE.

Rev.00

1/1
05/06/2024

GRNG

 Bocchetta in gomma con apertura di 160 mm, pinza grip con estremità gommate, manicotto di collegamento dotato di serranda a tenuta stagna, ingresso sonda per la prova opacimetrica.

 Rubber nozzle with 160 mm suction diameter, grip clamp with vulcanized rubber ends, hose coupling with fully tight closing valve and probe intake for C.O. test.

 Entonnoir en caoutchouc avec bouche d'aspiration de 160 mm de diamètre, pince étau avec terminals en caoutchouc, manchon avec registre étanche, grille anti-intrusion et entrée pour la sonde de l'opacimètre.

 Gummitrichter mit Saugöffnung DN 160 mm, Klemmzange mit vulkanisierten Gummischütze, Schlauch-Kupplung mit Integriertem Absperrklappe, Schutznetz und Öffnung für AU Sonde.

 Boquerel en goma con boca de aspiración de 160 mm completo de mordaza vulcanizada en goma, manguito con tapa de cierre hermética, rejilla anti-intrusión y toma para sonda.

cod.	IN	OUT	valv.	notes
GRNG-16075	160 mm	ø 75 mm	√	GRIP
GRNG-160100	160 mm	ø 100 mm	√	GRIP
GRNG-160125	160 mm	ø 125 mm	√	GRIP





www.worky-italy.com

via Masaccio, 15
42124 Reggio Emilia (RE) ITALY
Tel. +39 0522 1545193
vendite@worky-italy.com
sales@worky-italy.com

GRNG - technical datasheet

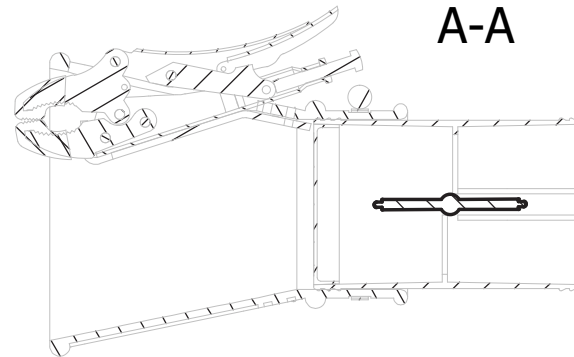
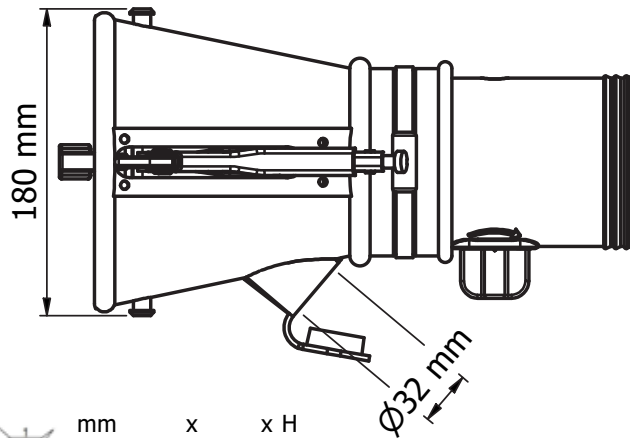
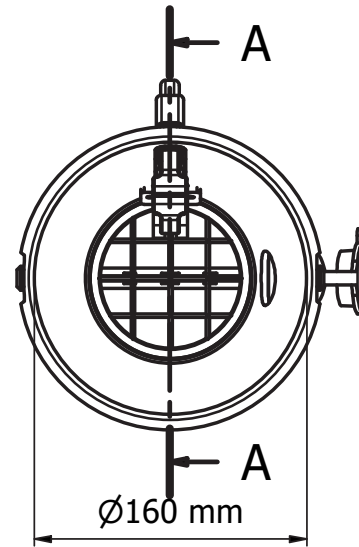
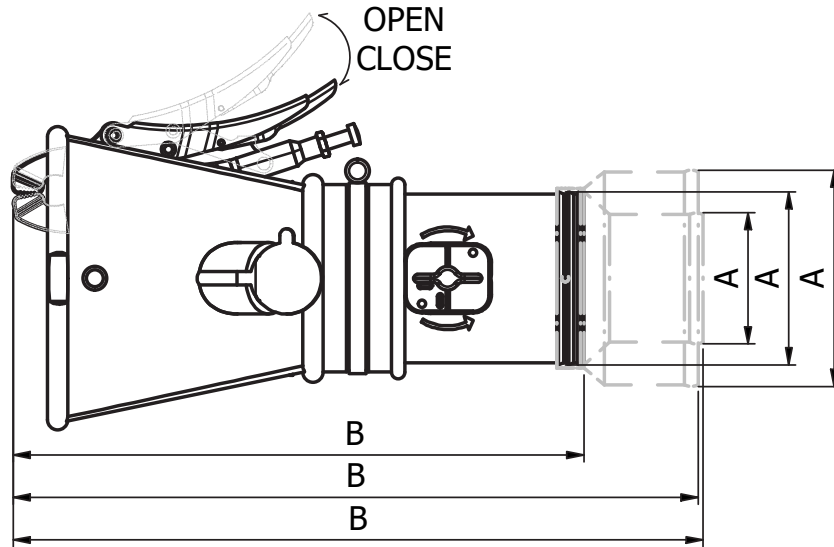

GRNG	A Ø	B
GRNG-16075	75 mm	405 mm
GRNG-160100	100 mm	335 mm
GRNG-160125	125 mm	402 mm



mm x x H

Kg 1.5

THIS DRAWING IS PROPERTY OF DEA + RO & Co S.p.A. THE COMPLETE OR PARTIAL REPRODUCTION OF THIS DOCUMENT IS FORBIDDEN. THE OWNER RESERVES THE RIGHT TO UPDATE, MODIFY OR AMEND ANY SPECIFICATION WITHOUT PRIOR NOTICE.

Rev.01

05/07/2022

GRNT-F



 Bocchetta in gomma con apertura di diam 160 mm dotata di membrana di ritenuta ed equipaggiata con filtro a carboni attivi. Il prodotto assorbe gli odori di gas ed é idoneo ad applicazioni con vetture al minimo per tempo limitato.

 Rubber nozzle with front membrane \varnothing 160 mm and with activated carbon filter in the back. Suitable for motors in idle mode for short time.

 Entonnoir en caoutchouc avec une ouverture de 160 mm, équipée d'une membrane de retenue et d'un filtre à charbon actif. Le produit absorbe les odeurs de gaz avec les voitures au ralenti pendant une durée limitée.

 Gummitrichter DN 160 mm, Rückhaltemembran, und mit einem Aktivkohlefilter ausgestattet. Das Produkt absorbiert Gasgerüche und ist für Anwendungen mit zeitlich begrenztem Leerlauf geeignet.

 Boquerel de goma con abertura de 160 mm de diámetro equipada con membrana de retención y provista de filtro de carbón activado. El producto absorbe los olores de los gases y es adecuado para aplicaciones con coches al ralentí durante un tiempo limitado.

cod.	IN	OUT	valv.	notes
GRNT-160F	160 mm	-	-	filter



via Masaccio, 15
42124 Reggio Emilia (RE) ITALY
Tel. +39 0522 1545193
vendite@worky-italy.com
sales@worky-italy.com

www.worky-italy.com

GRNT-160F - technical datasheet

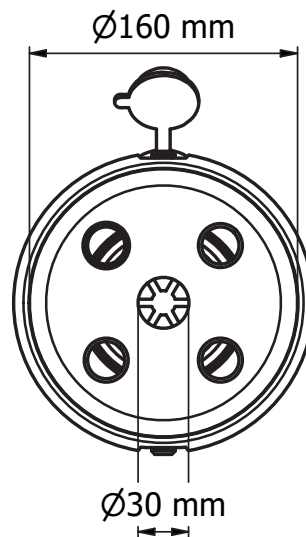
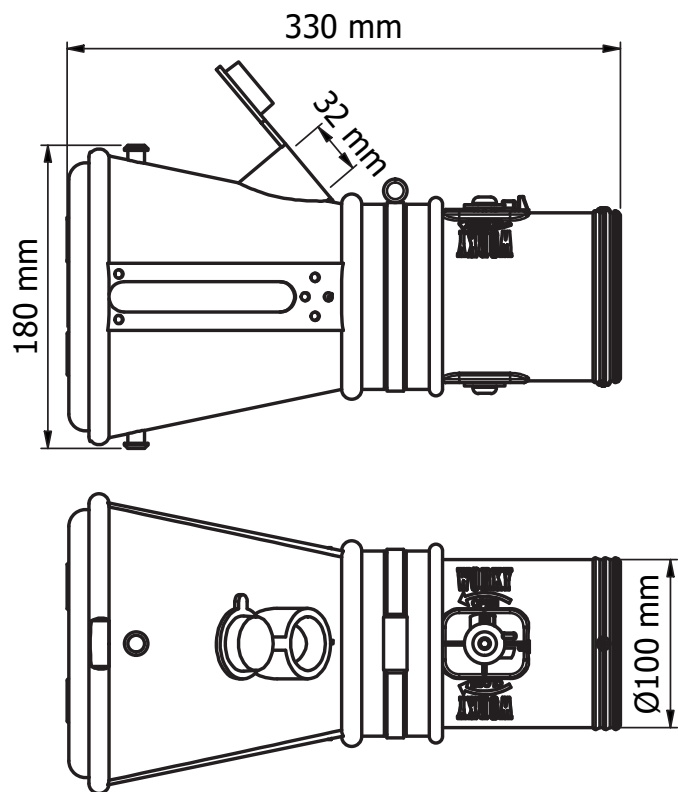

ATTENZIONE!

- Il prodotto GRNT-160F non può sostituire un impianto di evacuazione dei gas di scarico
- Il filtro a carboni assorbe il cattivo odore e alcune componenti del gas di scarico ma non il monossido di carbonio e altri gas tossici
- Usare con motore al minimo
- Il filtro ha una vita utile di circa 30 cicli di avviamento del motore.
- Non superare i 50°C di temperatura per non danneggiare le parti interne

WARNING!

- The GRNT-160F cannot be a substitute of a correct exhaust extraction system
- The active carbon filter is absorbing bad smell and some components of the exhaust gas, but not the carbon monoxide and other toxic gases
- Use only with car's engine in idle mode
- The filter has a lifetime of approximately 30 starting cycles
- Do not exceed 50°C of max temperature otherwise some internal parts will be damaged

GRC-K



 Curveta in gomma con apertura diametro 100 mm e clip per fissaggio ai tubi di scarico.

 Compact rubber curve with hose connection \varnothing 100 and opening \varnothing 100 equipped with clip to connect to exhaust pipe.

 Coude en caoutchouc avec ouverture de 100 mm de diamètre et clip de fixation aux pots d'échappement.

 Gummibogen mit Öffnung DN 100 mm und Befestigungsklip für Auspuffrohren.

 Codo de goma con abertura de 100 mm de diámetro y clip para fijación a los tubos de escape.

cod.	IN	OUT	valv.	notes
GRC-75K	100 mm	\varnothing 75 mm	-	clip
GRC-100K	100 mm	\varnothing 100 mm	√	clip



A brand of RO & CO S.p.A.
via Masaccio, 15
42124 Reggio Emilia (RE) ITALY
Tel. +39 0522 1545193
Fax +39 0522 1546451
vendite@worky-italy.com
sales@worky-italy.com
www.worky-italy.com

GRC-75K - technical datasheet

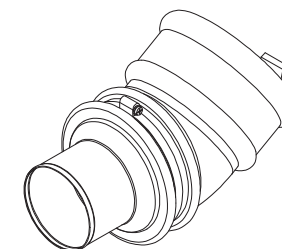
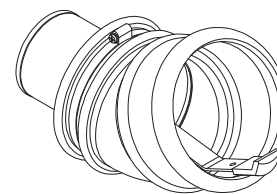
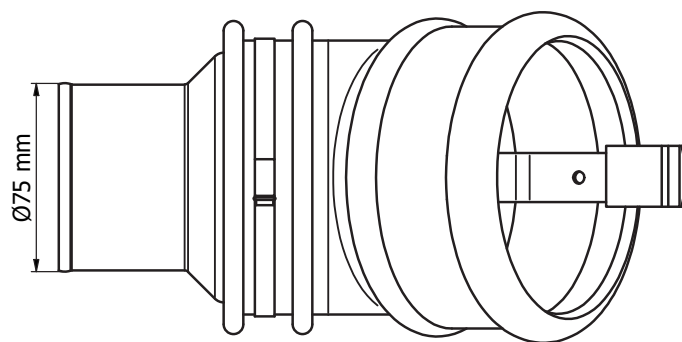
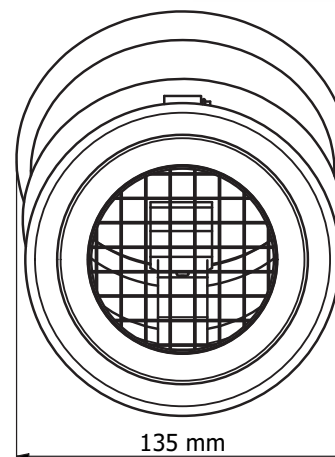
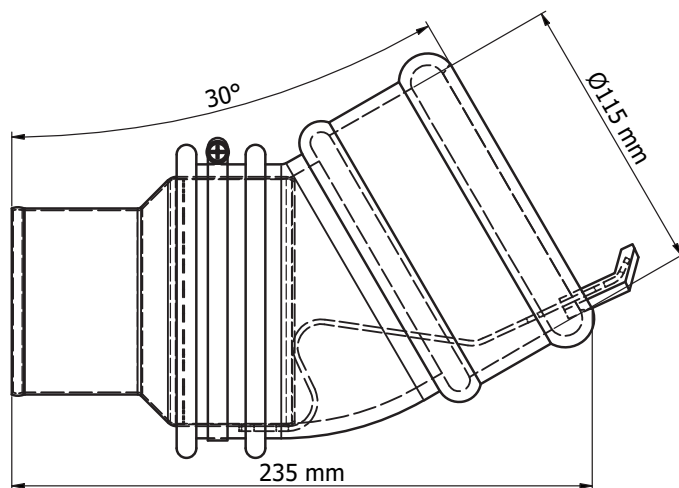
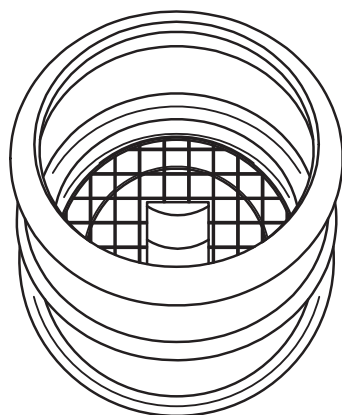

GRNP-M

 Bocchetta conica in gomma ad aggancio magnetico su piedistallo anch'esso con piede magnetico e base metallica di supporto.

 Conical rubber nozzle with magnetic coupling on a pedestal also with magnetic foot and metal support base.

 Entonnoir conique en caoutchouc avec accouplement magnétique sur un piédestal également avec pied magnétique et base de support métallique.

 Konische Gummidüse mit Magnetkupplung auf eine Stange, ebenfalls mit Magnetfuß und Metallunterlage.

 Boquerél cónico de goma con acoplamiento magnético sobre un pedestal también con pie magnético y base metálica de apoyo.

cod.	IN	OUT	valv.	notes
GRNP-75M	160 mm	ø 75 mm	-	Magnetic
GRNP-100M	160 mm	ø 100 mm	√	Magnetic
GRN-16075/SVM	160 mm	ø 75 mm	-	Magnetic
GRNP-A	-	-	-	mag. rod
GRNP-B	-	-	-	mag. base
GRN-KM	-	-	-	mag. kit





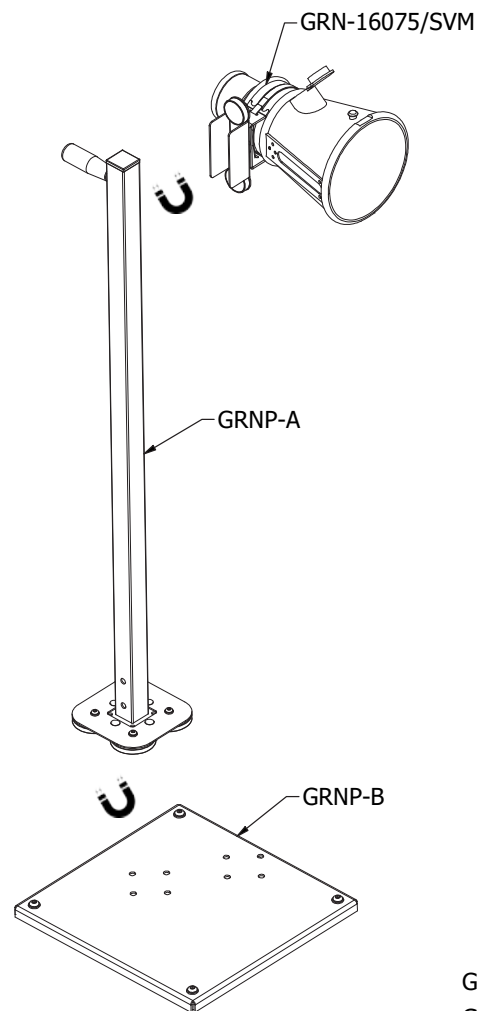
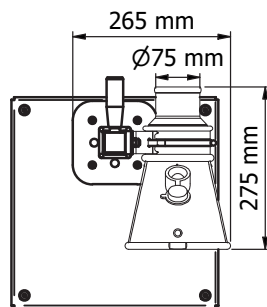
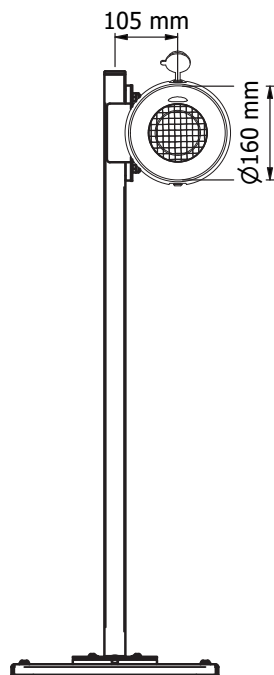
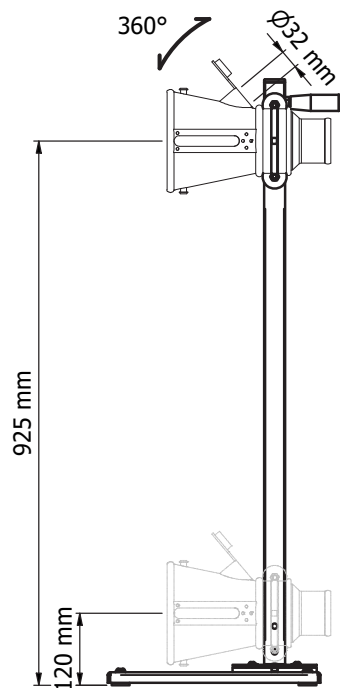

GRNP-75M - technical datasheet



GRN-16075/SVM + GRNP-A = 4.5 Kg
GRNP-B = 3 Kg

007.12.015.0







-  Tappo a membrana per bocchetta GRNT
-  Membrane cap for nozzle mod. GRNT
-  Bouchon à membrane pour entonnoir GRNT
-  Gummikappe für GRNT Trichtern
-  Tapón a membrana para boquerel GRNT

007.12.015.0	GRN	GON
007.12.015.0	√	-

007.12.016.0







-  Ralla curva a 30° per bocchette GRN e GON
-  30° bent rubber swivel for nozzles GRN and GON
-  Rotule en caoutchouc à 30° pour entonnoirs GRN et GON
-  30° gebogene Gummi-Dregelenk für GRN und GON Trichtern
-  Rodamiento en goma curvado de 30° para boquereles GRN y GON

007.12.016.0	GRN	GON
007.12.016.0	√	√

007.12.017.0



-  Maniglia in gomma per bocchette GRN
-  Rubber handle for GRN Nozzles
-  Prise en caoutchouc pour entonnoirs GRN
-  Gummi-Griff für GRN Trichtern
-  Agarradera en goma para boquereles GRN

007.12.017.0	GRN	GON
007.12.017.0	√	-



GV-100



 Tronchetto diam 100 in robusto materiale plastico caricato vetro resistente fino a 200°C dotato di serranda a farfalla e griglia anti intrusione.

 Heavy duty plastic cowling glass reinforced diam. 100 mm resistant up to 200°C equipped with butterfly valve and safety net.

 Manchon en plastique résistant avec fibre de verre diam. 100mm résistant jusqu'à 200°C, équipé avec registre de fermeture et grille stop-chiffon.

 Stark Kunststoffhulse DN 100 mm temperaturbeständig bis 200°C, ausgestattet mit Absperrklappe und Schutzgitter.

 Manguito en plastico reforzado con fibra de vidrio de diametro 100 mm resistente hasta 200°C de temperatura con tapa de cierre y rejilla anti-intrusión.

GV-100	GRN	GON
GV-100	√	√

010.14.04



 Riduzione in lamiera verniciata nera RAL9005 per variare il diametro 100 della serranda al diam 75 o 125 per attacco tubo.

 Reduction made of sheet metal to change the valve diam 100 mm to 75 or 125 mm.

 Réduction en tôle pour changer le diam. 100 mm du clapet en diam. 75 ou diam. 125 mm

 Reduktion aus Blech um den Klappen-DN 100 mm in DN 75 oder DN 125 zu ändern.

 Reducción en chapa para cambiar el diámetro de 100 mm a 75 mm o 125 mm.

010.14.04	GRN	GON
010.14.040.1-9005	100	75
010.14.041.1-9005	100	125

GON



 La bocchetta in gomma modello GON (Gas Oval Nozzle) presenta una bocca di aspirazione di 210 mm x 105 mm ed è stata sviluppata da WORKY per seguire lo sviluppo dei tubi di scarico delle vetture sportive.

Il prodotto è stato ottimizzato per scarichi accoppiati, scarichi accoppiati su entrambi i lati del veicolo e tubi di scarico completamente integrati nel paraurti.

Tutte le versioni di pinza sono disponibili sia sul lato sinistro del cono (versione standard) che sul lato destro. Grazie a questa flessibilità è molto facile fissare la GON su auto con doppio scarico.

 The GON (Gas Oval Nozzle) rubber nozzle has a suction intake of 210 mm x 105 mm and was developed by WORKY to follow the development of the exhaust pipes of sports cars.

The product has been optimized for coupled exhausts, coupled exhausts on both sides of the vehicle and exhaust pipes fully integrated into the rear bumper.

All clamp versions are available on both the left side of the cone (standard version) and on the right side. Thanks to this flexibility, it is very easy to fix the GON on cars with double exhaust pipes.

 L'entonnoir en caoutchouc GON (Gas Oval Nozzle) a une bouche d'aspiration de 210 mm x 105 mm et a été étudié par WORKY pour suivre le développement des pots d'échappement des voitures de sport.

Le produit a été optimisé pour les échappements couplés, les échappements couplés des deux côtés du véhicule et les pots d'échappement complètement intégrés dans le pare-chocs.

Toutes les versions de pinces sont disponibles sur le côté gauche du cône (version standard) et sur le côté droit. Grâce à cette flexibilité, il est très facile d'agrafer le GON sur un double pot d'échappement.

 Die GON (Gas Oval Nozzle) Gummitrichter hat eine Saugöffnung von 210 mm x 105 mm und wurde von WORKY entwickelt, um die Fortschritte der Auspuffrohre von Sportwagen zu verfolgen.

Das Produkt wurde für gekoppelte Abgasrohre, gekoppelte Auspuffungen auf beiden Seiten des Fahrzeugs und für vollständig in den Stoßfänger integrierte Auspuffrohre optimiert.

Alle Klemmversionen sind sowohl auf der linken Seite des Kegels (Standardausführung) als auch auf der rechten Seite vorhanden. Dank dieser Flexibilität ist es sehr einfach, das GON in einem PKW mit Doppelauspuff anzuschließen.

 El boquerel en goma GON (Gas Oval Nozzle) tiene una boca de aspiración de 210 mm x 105 mm y fue desarrollada por WORKY para seguir la evolución de los tubos de escape de los coches deportivos.

El producto ha sido optimizado para los tubos de escape acoplados, dobles, dobles en ambos lados del vehículo y los tubos de escape totalmente integrados en los parachoques.

Todas las versiones de mordazas están disponibles tanto en el lado izquierdo del cono (versión estándar) como en el lado derecho. Gracias a esta flexibilidad, es muy fácil fijar el boquerel GON en turismos con doble escape.

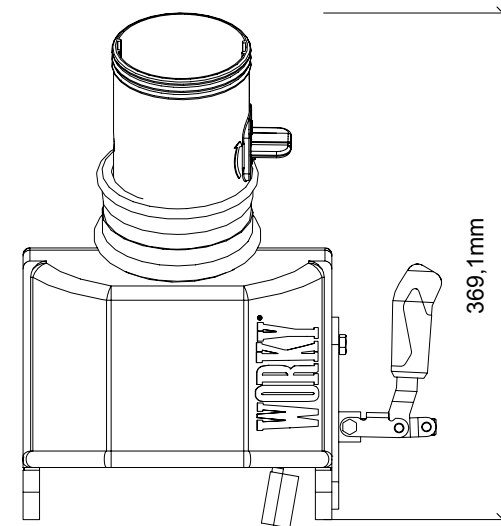
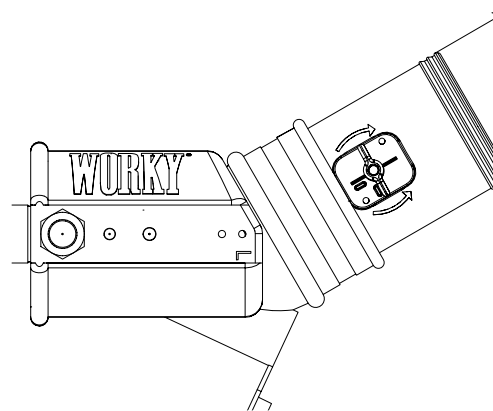
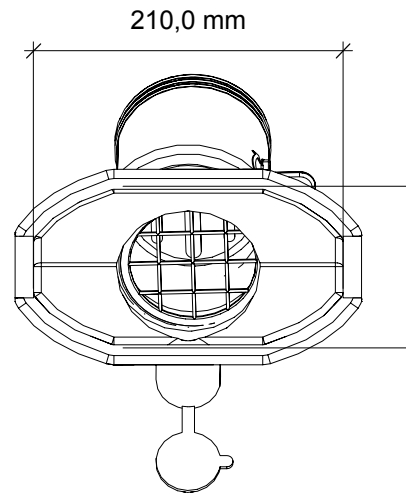

GON

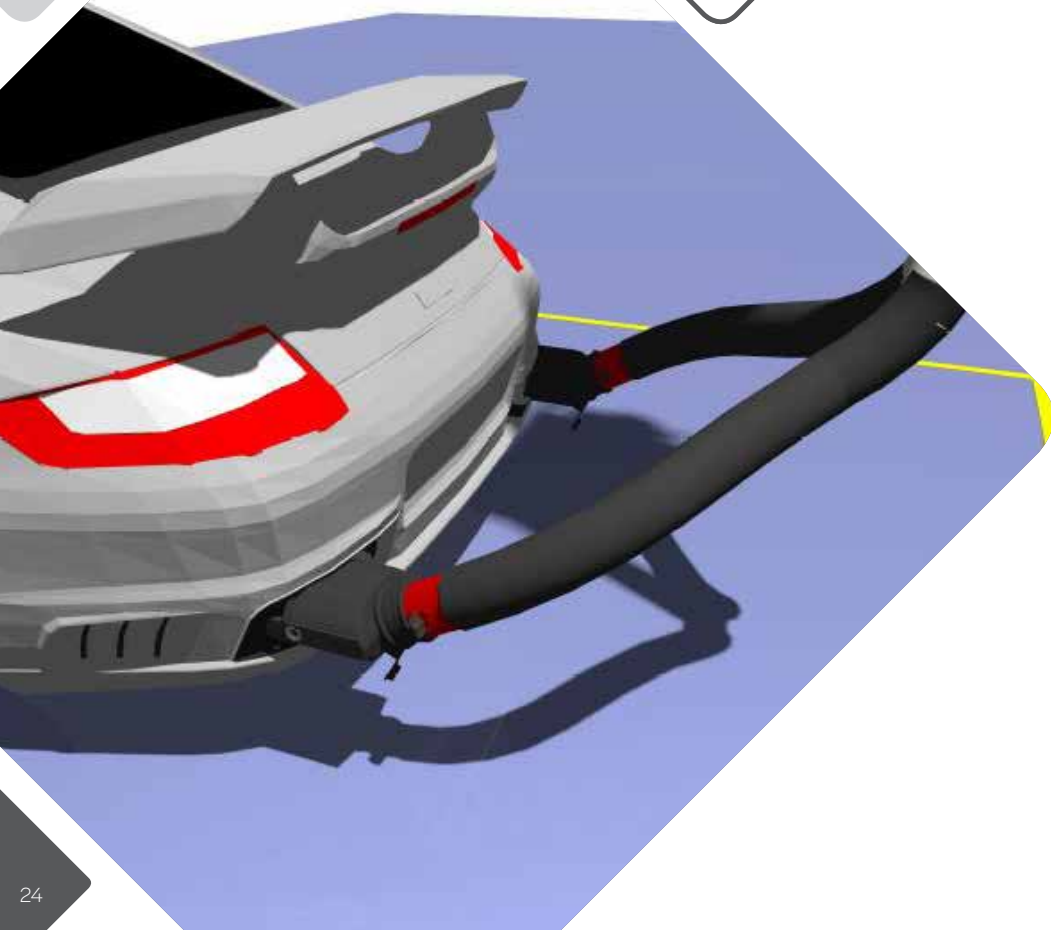

 Bocchetta ovale in gomma con apertura di 210 x 105 mm, manicotto di collegamento curvato di 30° dotato di serranda manuale a tenuta stagna, ingresso sonda per la prova opacimetrica.

 Oval rubber nozzle with 210 x 105 mm suction opening and 30° hose coupling with fully tight manual closing valve, probe for C.O. test.

 Entonnoir ovale en caoutchouc avec bouche d'aspiration 210 mm x 105 mm, coffre courbé à 30° avec registre étanche, grille anti-intrusion et entrée pour la sonde de l'opacimètre.

 Ovaler Gummitrichter mit Saugöffnung 210 mm x 105 mm, 30° Kurve mit integrierter Absperrklappe mit Schutznetz und Öffnung für AU Sonde.

 Boquerel oval en goma 210 mm x 105 mm completo de manguito con curva de 30° y tapa de cierre hermética, rejilla anti-intrusión y toma para sonda.

cod.	IN	OUT	valv.	notes
GON-75	210 x105 mm	ø 75 mm	√	-
GON-100	210 x105 mm	ø 100 mm	√	-
GON-125	210 x105 mm	ø 125 mm	√	-



via Masaccio, 15
42124 Reggio Emilia (RE) ITALY
Tel. +39 0522 1545193
vendite@worky-italy.com
sales@worky-italy.com

www.worky-italy.com

GON - technical datasheet

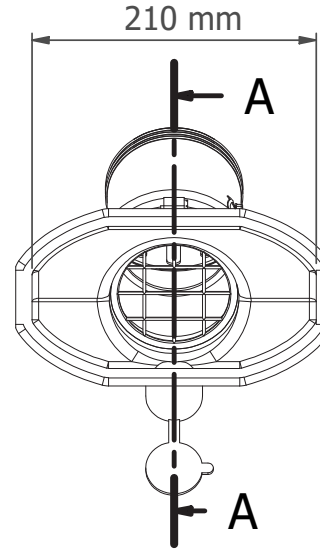
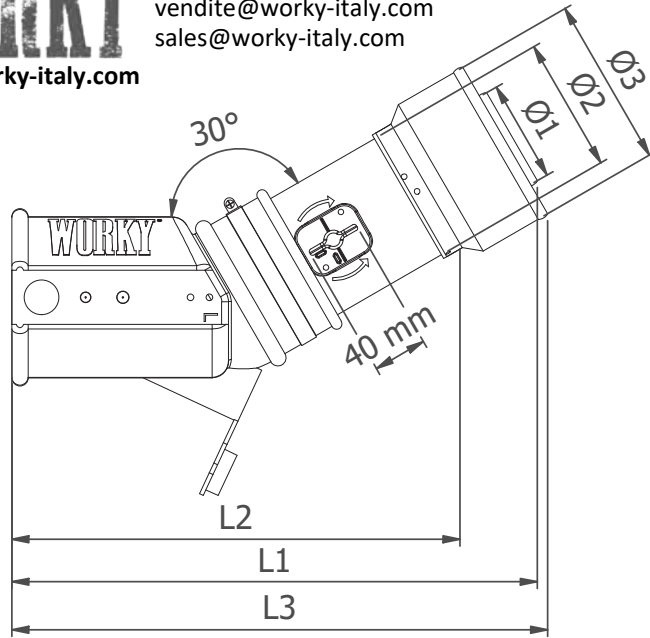

A-A

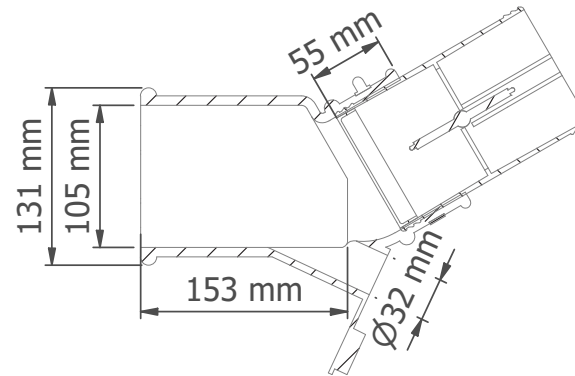
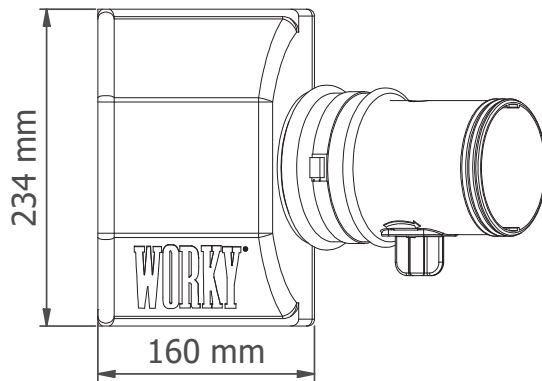

	COD	LTOT [mm]	Ø [mm]	PACK			Kg Tot
				l [mm]	w [mm]	h [mm]	
1	GON-75	388	75	400	300	220	2
2	GON-100	331	100	400	300	220	2
3	GON-125	396	125	400	300	220	2

THIS DRAWING IS PROPERTY OF DEA + RO & Co S.p.A. THE COMPLETE OR PARTIAL REPRODUCTION OF THIS DOCUMENT IS FORBIDDEN. THE OWNER RESERVES THE RIGHT TO UPDATE, MODIFY OR AMEND ANY SPECIFICATION WITHOUT PRIOR NOTICE.

Rev.00

1/1
17/06/2024

GON-K



 Bocchetta ovale in gomma con bocca di aspirazione da 210 mm x 105 mm, tronchetto curvato di 30° dotato di serranda di chiusura a tenuta stagna, griglia anti intrusione, ingresso sonda e clip di fissaggio vulcanizzata in gomma.

 Oval rubber nozzle with 210 x 105 mm suction opening and 30° hose coupling with fully tight manual closing valve, probe for C.O. test and fixing clip with vulcanized rubber end.

 Entonnoir ovale en caoutchouc avec bouche d'aspiration 210 mm x 105 mm, coffre courbé à 30° avec registre étanche, grille anti-intrusion, entrée pour la sonde de l'opacimètre et clip de fixation avec terminal en caoutchouc.

 Ovaler Gummitrichter mit Saugöffnung 210 mm x 105 mm, 30° Kurve mit integrierter Absperrklappe mit Schutznetz, Öffnung für AU Sonde, Stahlfixierung-Klemmvorrichtung mit vulkanisiertem Gummischutz.

 Boquerel oval en goma 210 mm x 105 mm completo de manguito con curva de 30° y tapa de cierre hermética, rejilla anti-intrusión, toma para sonda y clip de fijación con terminal en goma.



cod.	Ø	Posizione clip / Clip position
GON-75K	75 mm	sinistra / left
GON-75KR	75 mm	destra / right
GON-100K	100 mm	sinistra / left
GON-100KR	100 mm	destra / right
GON-125K	125 mm	sinistra / left
GON-125KR	125 mm	destra / right

WORKY

via Masaccio, 15
42124 Reggio Emilia (RE) ITALY
Tel. +39 0522 1545193
vendite@worky-italy.com
sales@worky-italy.com

www.worky-italy.com

GON-100K - technical datasheet

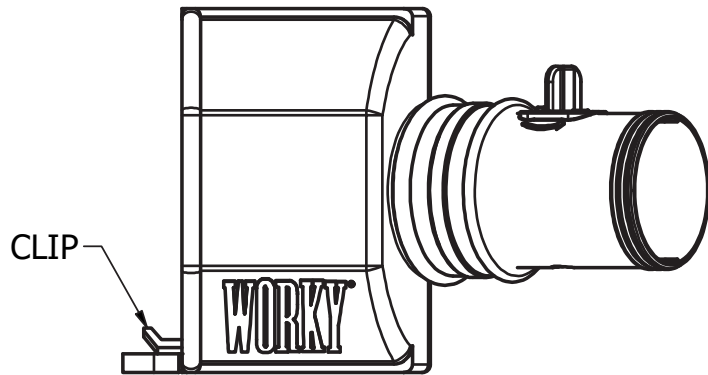
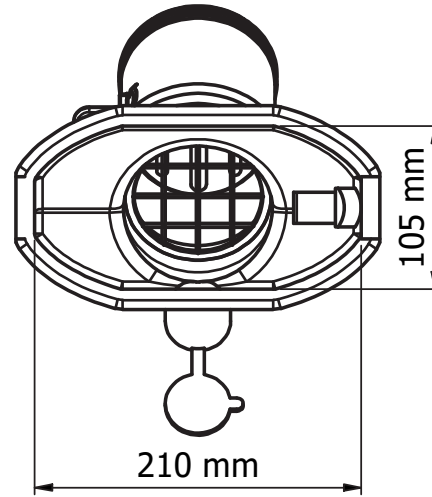
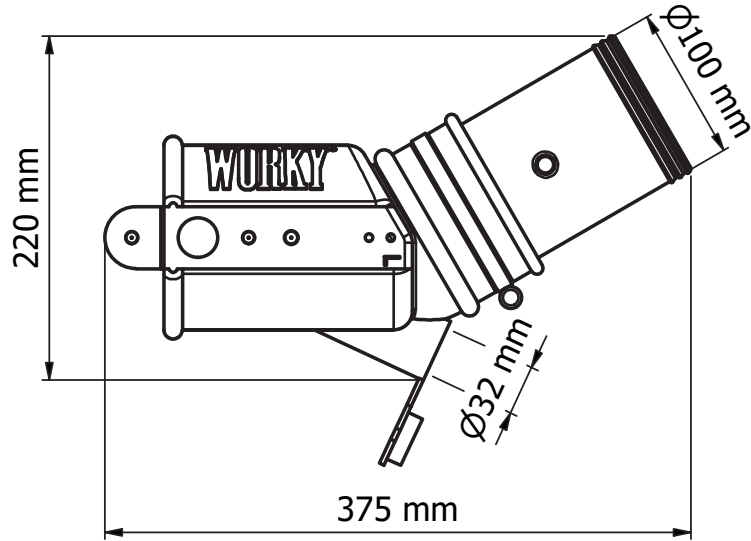



GON-MG



 Bocchetta ovale in gomma con bocca di aspirazione da 210 mm x 105 mm, tronchetto curvato di 30° dotato di serranda di chiusura a tenuta stagna, griglia anti intrusione, ingresso sonda e pinza di fissaggio con rostro vulcanizzato in gomma.

 Oval rubber nozzle with 210 x 105 mm suction opening and 30° hose coupling with fully tight manual closing valve, probe for C.O. test and fixing gripper with vulcanized rubber ends.

 Entonnoir ovale en caoutchouc avec bouche d'aspiration 210 mm x 105 mm, coffre courbé à 30° avec registre étanche, grille anti-intrusion, entrée pour la sonde de l'opacimètre et pince étau avec terminales en caoutchouc.

 Ovaler Gummitrichter mit Saugöffnung 210 mm x 105 mm, 30° Kurve mit integrierter Absperrklappe mit Schutznetz, Öffnung für AU Sonde, Klemmzange mit vulkanisiertem Gummischutz.

 Boquerel oval en goma 210 mm x 105 mm completo de manguito con curva de 30° y tapa de cierre hermética, rejilla anti-intrusión, toma para sonda y mordaza con terminal en goma.

cod.	IN	OUT	valv.	notes
GON-75MG	210 x105 mm	ø 75 mm	√	GRIP
GON-100MG	210 x105 mm	ø 100 mm	√	GRIP
GON-125MG	210 x105 mm	ø 125 mm	√	GRIP
GON-75MGR	210 x105 mm	ø 75 mm	√	RIGHT GRIP
GON-100MGR	210 x105 mm	ø 100 mm	√	RIGHT GRIP
GON-125MGR	210 x105 mm	ø 125 mm	√	RIGHT GRIP



via Masaccio, 15
42124 Reggio Emilia (RE) ITALY
Tel. +39 0522 1545193
vendite@worky-italy.com
sales@worky-italy.com

www.worky-italy.com

GON-MG - technical datasheet

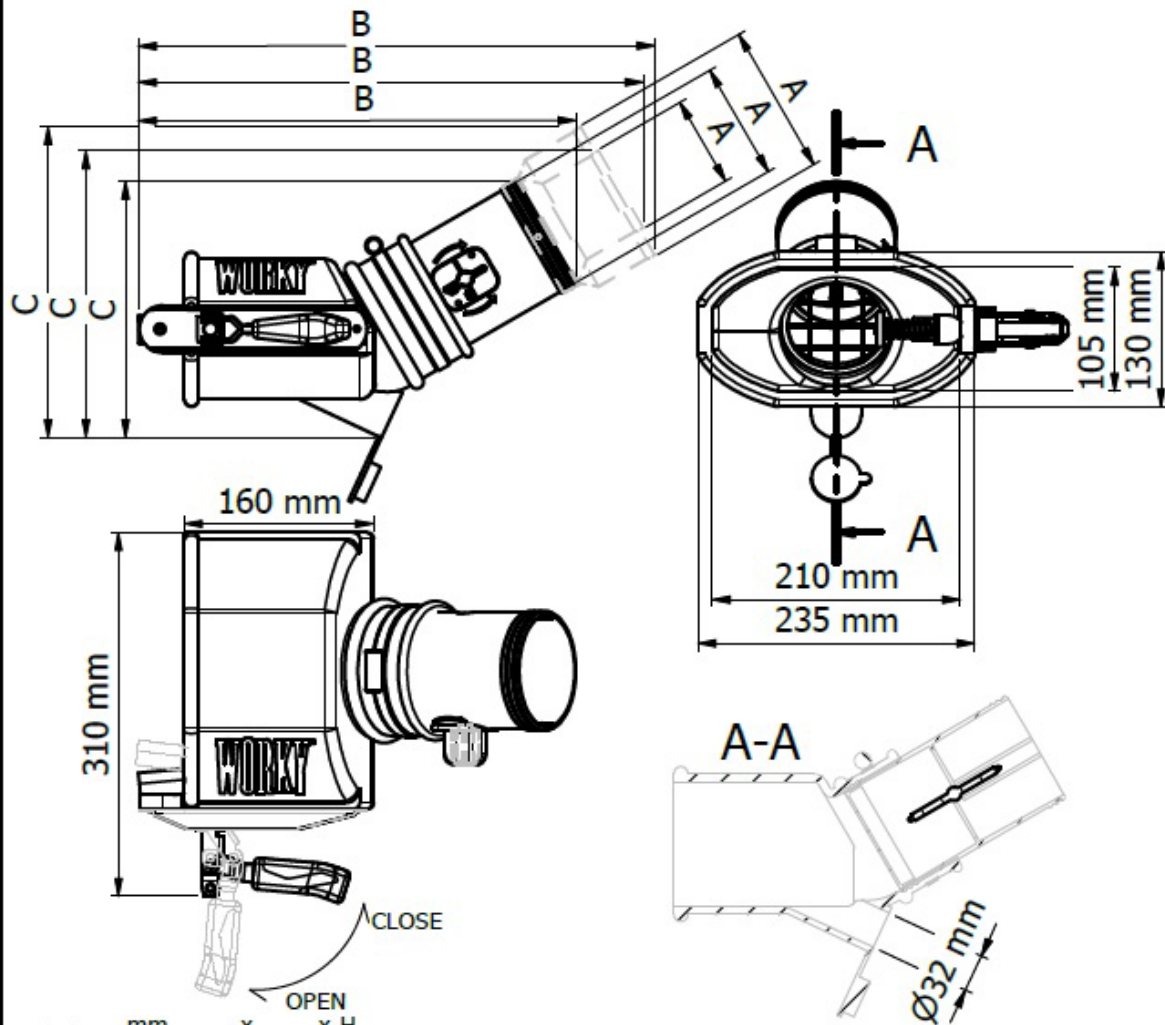
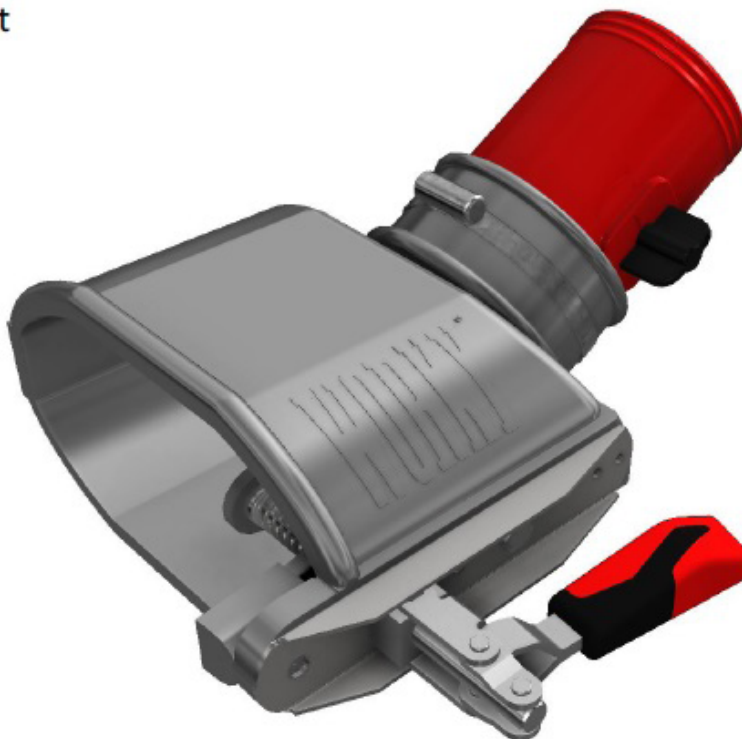



GON-MG	A Ø	B	C
GON-75MG	75 mm	425 mm	240 mm
GON-100MG	100 mm	370 mm	220 mm
GON-125MG	125 mm	435 mm	260 mm

mm x x H
Kg 2.5

GON-EG



 Bocchetta ovale in gomma con bocca di aspirazione da 210 mm x 105 mm, tronchetto curvato di 30° dotato di serranda di chiusura a tenuta stagna, griglia anti intrusione, ingresso sonda e pinza interna ad espansione con becchi regolabili.

 Oval rubber nozzle with 210 x 105 mm suction opening and 30° hose coupling with fully tight manual closing valve, probe for C.O. test and internal expanding grip with adjustable beaks.

 Entonnoir ovale en caoutchouc avec bouche d'aspiration 210 mm x 105 mm, coffre courbé à 30° avec registre étanche, grille anti-intrusion, entrée pour la sonde de l'opacimètre et pince interne à expansion avec extrémités réglables.

 Ovaler Gummitrichter mit Saugöffnung 210 mm x 105 mm, 30° Kurve mit integrierter Absperrklappe mit Schutznetz, Öffnung für AU Sonde, innere Klemmzange zu erweitern.

 Boquerel oval en goma 210 mm x 105 mm completo de manguito con curva de 30° y tapa de cierre hermética, rejilla anti-intrusión, toma para sonda y mordaza interna a expansión.

cod.	IN	OUT	valv.	notes
GON-75EG	210 x105 mm	ø 75 mm	√	INSIDE GRIP
GON-100EG	210 x105 mm	ø 100 mm	√	INSIDE GRIP
GON-125EG	210 x105 mm	ø 125 mm	√	INSIDE GRIP
GON-75EGR	210 x105 mm	ø 75 mm	√	RIGHT IN. GRIP
GON-100EGR	210 x105 mm	ø 100 mm	√	RIGHT IN. GRIP
GON-125EGR	210 x105 mm	ø 125 mm	√	RIGHT IN. GRIP



via Masaccio, 15
 42124 Reggio Emilia (RE) ITALY
 Tel. +39 0522 1545193
 vendite@worky-italy.com
 sales@worky-italy.com

www.worky-italy.com

GON-EG - technical datasheet

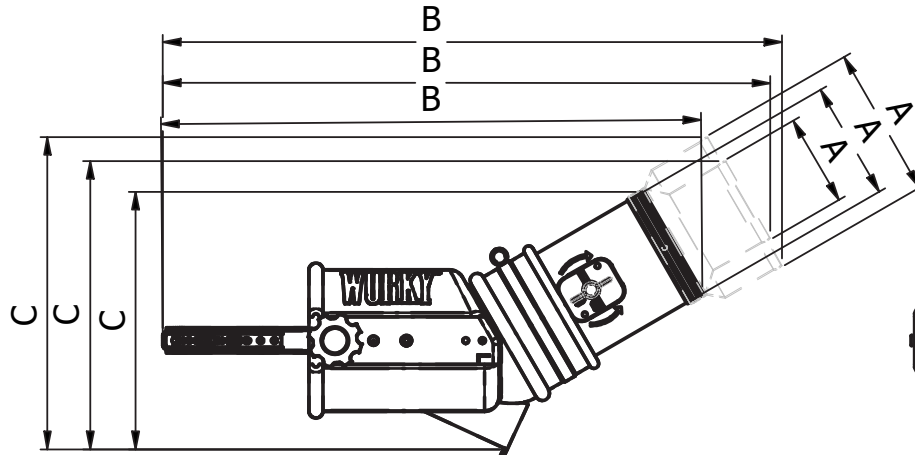
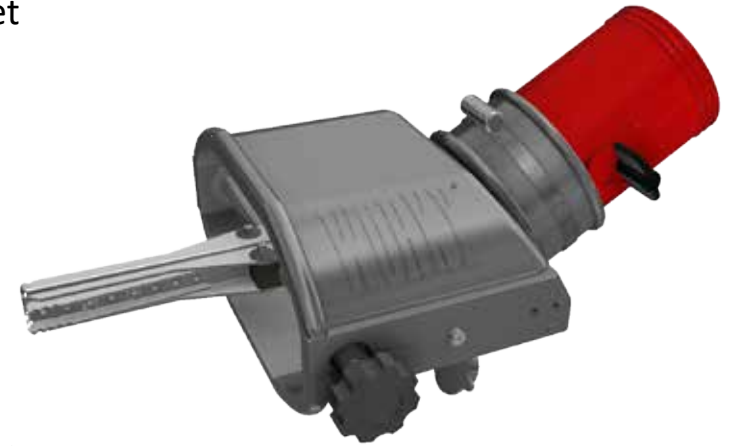

MIN 125 mm
 MAX 195 mm

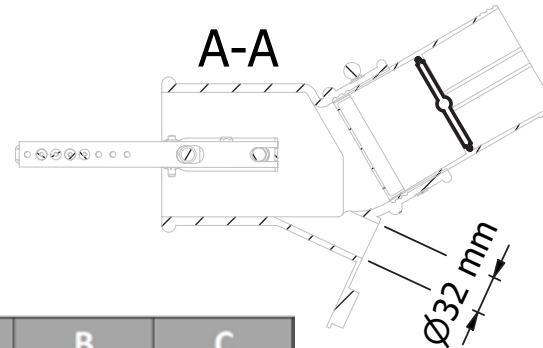
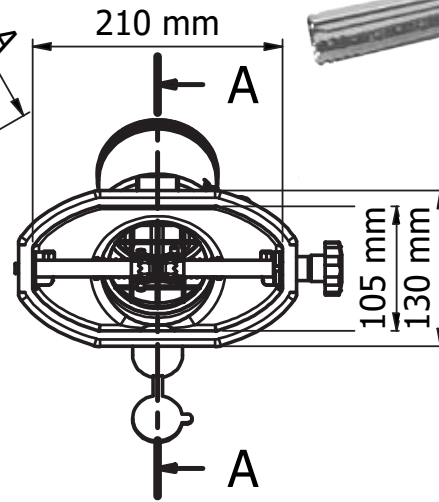
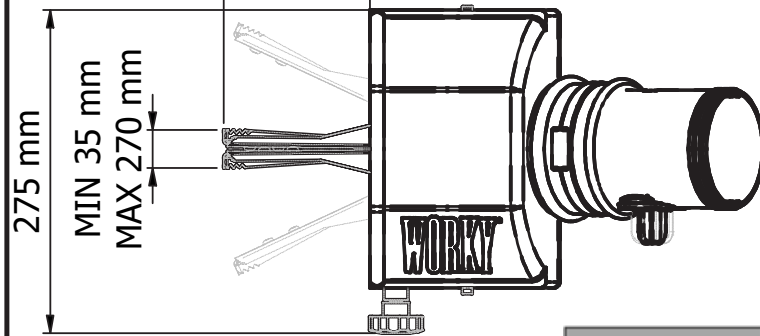

GON-EG	A Ø	B	C
GON-75EG	75 mm	510 mm	245 mm
GON-100EG	100 mm	455 mm	215 mm
GON-125EG	125 mm	520 mm	265 mm

mm x x H
 Kg 2.5

THIS DRAWING IS PROPERTY OF RO & Co S.p.A. THE COMPLETE OR PARTIAL REPRODUCTION OF THIS DOCUMENT IS FORBIDDEN. THE OWNER RESERVES THE RIGHT TO UPDATE, MODIFY OR AMEND ANY SPECIFICATION WITHOUT PRIOR NOTICE.

Rev.00

11/06/2021



GRTN

 La bocchetta in gomma modello GRTN (Gas Rubber Truck Nozzle) presenta una bocca di aspirazione con diametro di 185 mm e una struttura robusta per adattarsi perfettamente agli impieghi gravosi delle officine camion.

Il prodotto è stato ottimizzato per accogliere la serranda di chiusura stagna all'interno del corpo bocchetta unitamente alla griglia anti intrusione; in questo modo il prodotto rimane compatto e flessibile per potersi collegare anche a marmitte difficili da raggiungere.

La bocchetta GRTN è configurata con varie tipologie di pinza per adattarsi ad ogni esigenza di fissaggio.

 The GRTN (Gas Rubber Truck Nozzle) rubber nozzle has a 185 mm wide suction intake and a robust design to perfectly fit the heavy duty truck application.

The product has been optimized to accommodate the fully tight closing valve inside the nozzle body, together with the protection net; in this way, the product remains compact and flexible so that it can also be connected to mufflers difficult to reach.

The GRTN nozzle is configured with various types of grippers to fit every need of exhaust pipe fastening.

 L'entonnoir en caoutchouc GRTN (Gas Rubber Truck Nozzle) a une bouche d'aspiration de 185 mm de diamètre et une conception robuste pour s'adapter parfaitement au travail dans les ateliers PL.

Le produit a été optimisé pour accueillir la soupape étanche à l'intérieur du corps en caoutchouc avec la grille anti-intrusion; de cette façon, le produit reste compact et flexible de sorte qu'il peut également être connecté aux pots d'échappement difficiles à atteindre.

L'entonnoir GRTN est configuré avec différents types de pinces pour s'adapter à tous les besoins de fixation.

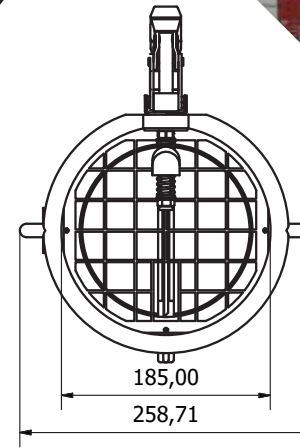
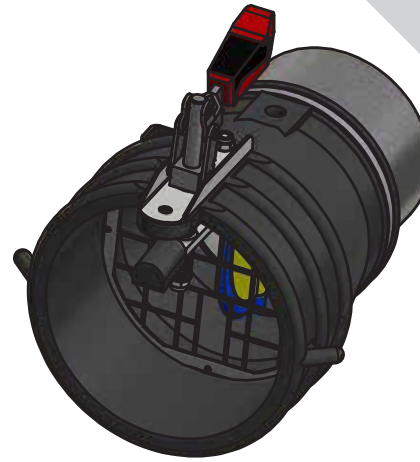

 Die GRTN (Gas Rubber Truck Nozzle) Gummi-Trichter hat eine Saugöffnung von 185 mm Durchmesser und ein robustes Design, um die schwere Lkw-Arbeit perfekt zu erfüllen.

Das Produkt wurde optimiert, um die dichte Absperrklappe innerhalb des Trichterkörpers zusammen mit dem Anti-Einbruchgitter aufzunehmen; auf dieser Weise bleibt das Produkt kompakt und flexibel, so dass es auch an schwer zugängliche Auspuff-Anlage angeschlossen werden kann.

Die GRTN Trichter ist mit verschiedenen Greifertypen für jeden Befestigungsbedarf konfiguriert.

 El boquerel en goma GRTN (Gas Rubber Truck Nozzle) tiene una boca de aspiración de 185 mm de diámetro y un diseño robusto para encajar perfectamente en el trabajo pesado de un taller camión.

El producto ha sido optimizado para alojar un tapa de cierre dentro del cuerpo del boquerel junto con la rejilla antiintrusión; de esta manera el producto permanece compacto y flexible de modo que también puede conectarse a escapes de difícil acceso.

El boquerel GRTN está configurado con varios tipos de pinzas para adaptarse a todas las necesidades de fijación.

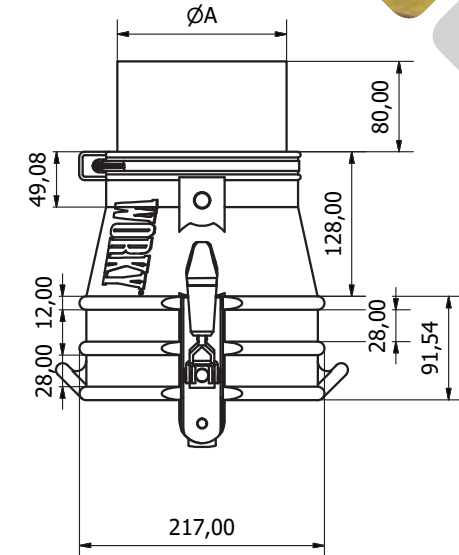
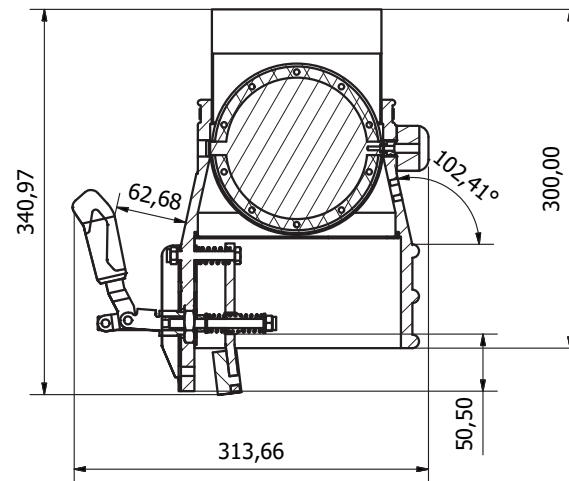

GRTN

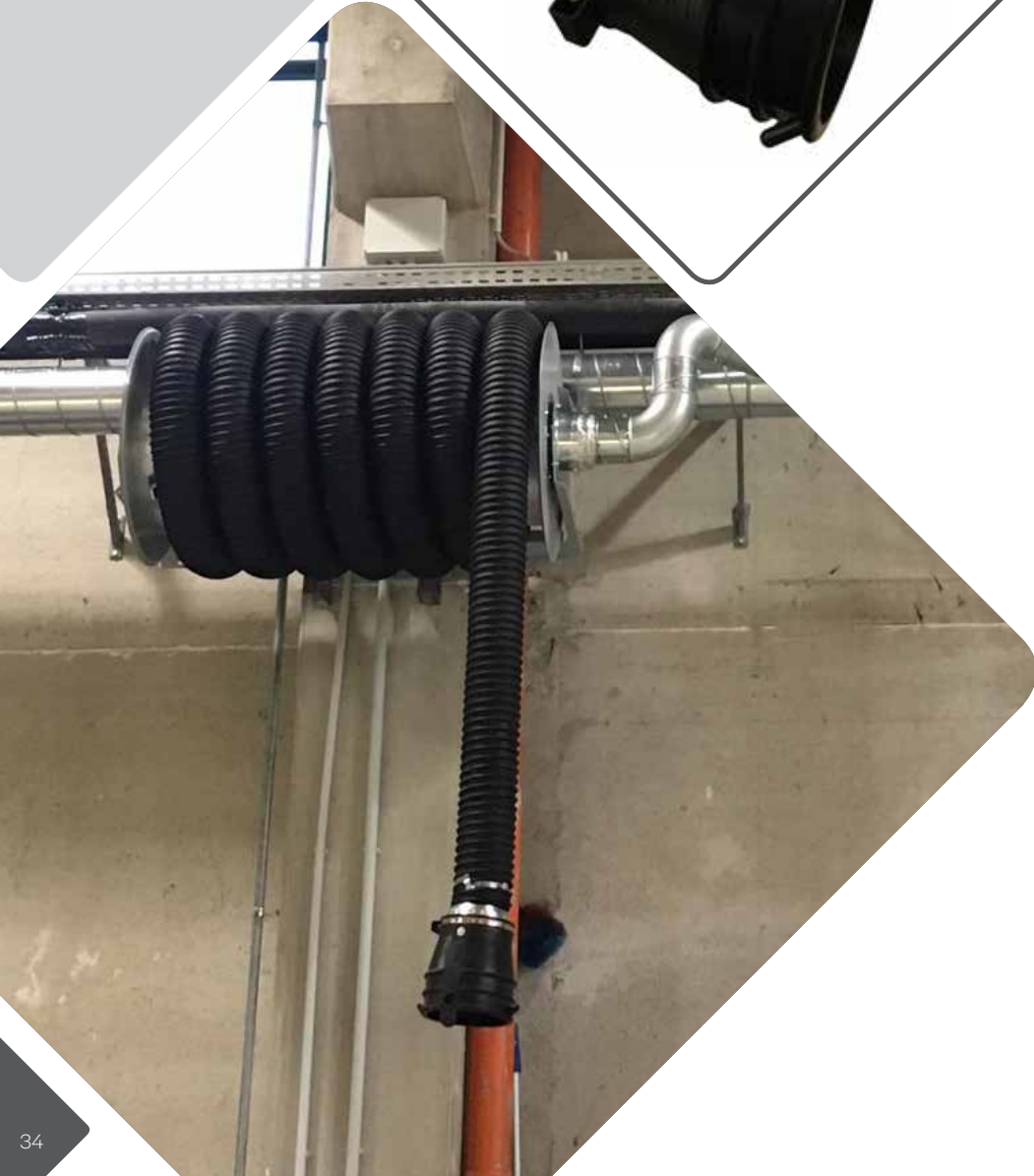

 Bocchetta in gomma per impieghi gravosi con rete anti intrusione, serranda a tenuta stagna inclusa nel corpo della bocchetta e bocca di aspirazione da 185 mm.

 Heavy duty rubber nozzle with fully tight closing valve included in the body of the product, protection net and suction intake diam 185 mm.

 Entonnoir en caoutchouc pour PL avec soupape étanche inclus dans le corp du produit, réseau anti-intrusion et bouche aspirante de 185 mm de diamètre.

 Gummitrichter für LKW mit Schutzgitter, dichter Absperrklappe im Trichterkörper integriert und Saugöffnung DN 185 mm.

 Boquerel en goma para vehiculos pesados con rejilla anti-intrusión, tapa de cierre incluida en el cuerpo del producto y boca de aspiración de 185 mm de diámetro.

cod.	IN	OUT	valv.	notes
GRTN-75	185 mm	ø 75 mm	√	HEAVY DUTY
GRTN-100	185 mm	ø 100 mm	√	HEAVY DUTY
GRTN-125	185 mm	ø 125 mm	√	HEAVY DUTY
GRTN-150	185 mm	ø 150 mm	√	HEAVY DUTY



A brand of RO & CO S.p.A
 via G. di Vittorio, 1
 42025 Cavriago (RE) ITALY
 Tel. +39 0522 1545193
 Fax +39 0522 1546451
 vendite@worky-italy.com
 sales@worky-italy.com
 www.worky-italy.com

GRTN

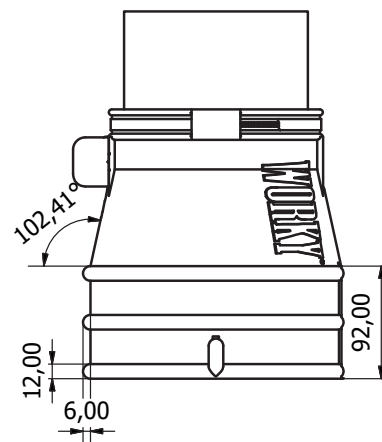
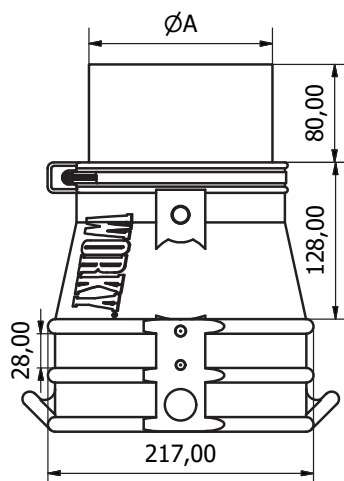
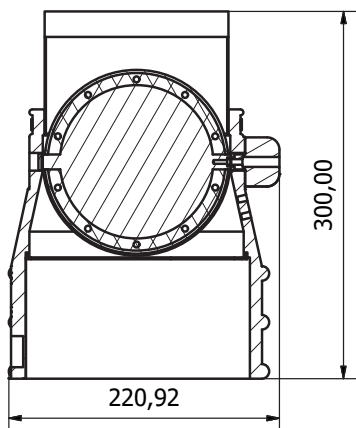
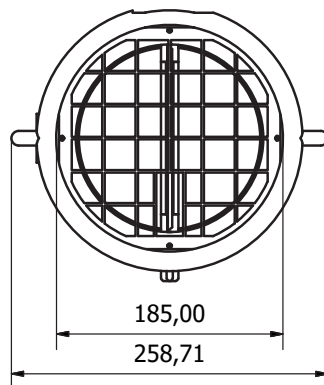

Model	A [mm]
GRTN-100	100
GRTN-125	125
GRTN-150	150

E' VIETATA LA RIPRODUZIONE TOTALE E/O PARZIALE DEL PRESENTE DISEGNO CHE E' DI PROPRIETA' DI RO & CO SPA PI02492210352
 RO & CO SPA SI RISERVA LA FACOLTA' DI AGGIORNARE E O MODIFICARE TUTTO O IN PARTE LE PRESENTI SPECIFICHE SENZA PREAVVISO.

Rev.

03/08/2017

GRTN-M



 Bocchetta in gomma per impieghi gravosi con rete anti intrusione, serranda a tenuta stagna inclusa nel corpo della bocchetta, magneti di fissaggio al tubo di scarico e bocca di 185 mm.

 Heavy duty rubber nozzle with fully tight closing valve included in the body of the product, protection net, magnets for fixing to the exhaust pipe and suction intake diam 185 mm.

 Entonnoir en caoutchouc pour PL avec soupape étanche inclus dans le corp du produit, réseau anti-intrusion, aimants de fixation au pot d'échappement et bouche aspirante de 185 mm de diamètre.

 Gummitrichter für LKW mit Schutzgitter, dichter Absperrklappe im Trichterkörper integriert, Magneten und Saugmund DN 185 mm.

 Boquerel en goma para vehiculos pesados con rejilla anti-intrusión, tapa de cierre incluida en el cuerpo del producto, imanes de fijación y boca de aspiración de 185 mm de diámetro.

cod.	IN	OUT	valv.	notes
GRTN-100M	185 mm	ø 100 mm	√	MAGNET
GRTN-125M	185 mm	ø 125 mm	√	MAGNET
GRTN-150M	185 mm	ø 150 mm	√	MAGNET



via Masaccio, 15
42124 Reggio Emilia (RE) ITALY
Tel. +39 0522 1545193
vendite@worky-italy.com
sales@worky-italy.com

www.worky-italy.com

GRTN-M - technical datasheet

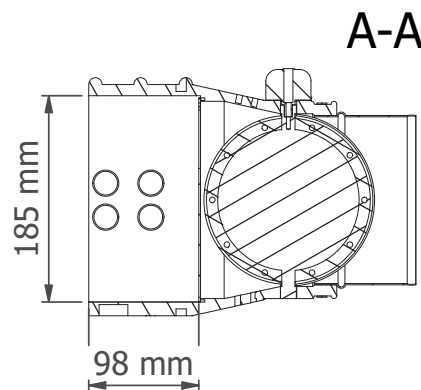
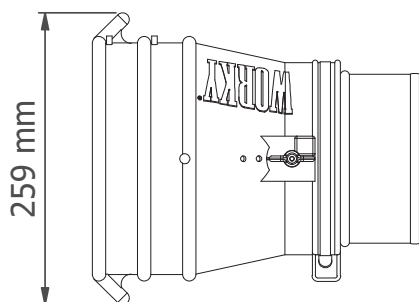
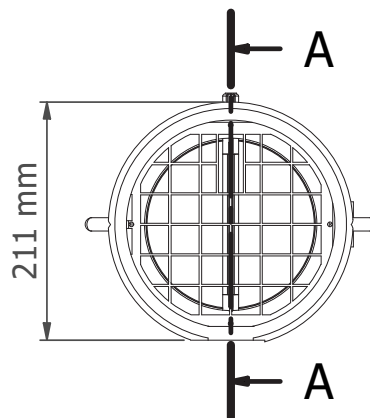
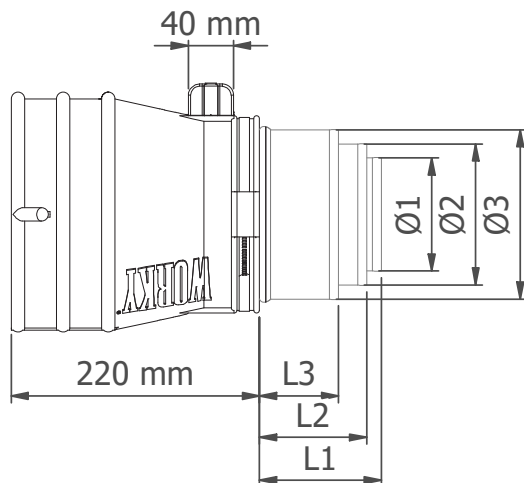

	COD	L [mm]	L Tot [mm]	Ø [mm]	PACK			Kg Tot
					l [mm]	w [mm]	h [mm]	
1	GRTN-100M	108	328	100	350	350	370	4
2	GRTN-125M	95	315	125	350	350	370	4
3	GRTN-150M	70	290	150	350	350	370	4

THIS DRAWING IS PROPERTY OF DEA + RO & Co.s.p.a. THE COMPLETE OR PARTIAL REPRODUCTION OF THIS DOCUMENT IS FORBIDDEN. THE OWNER RESERVES THE RIGHT TO UPDATE, MODIFY OR AMEND ANY SPECIFICATION WITHOUT PRIOR NOTICE.

Rev.00

1/1
10/06/2024

GRTN-K

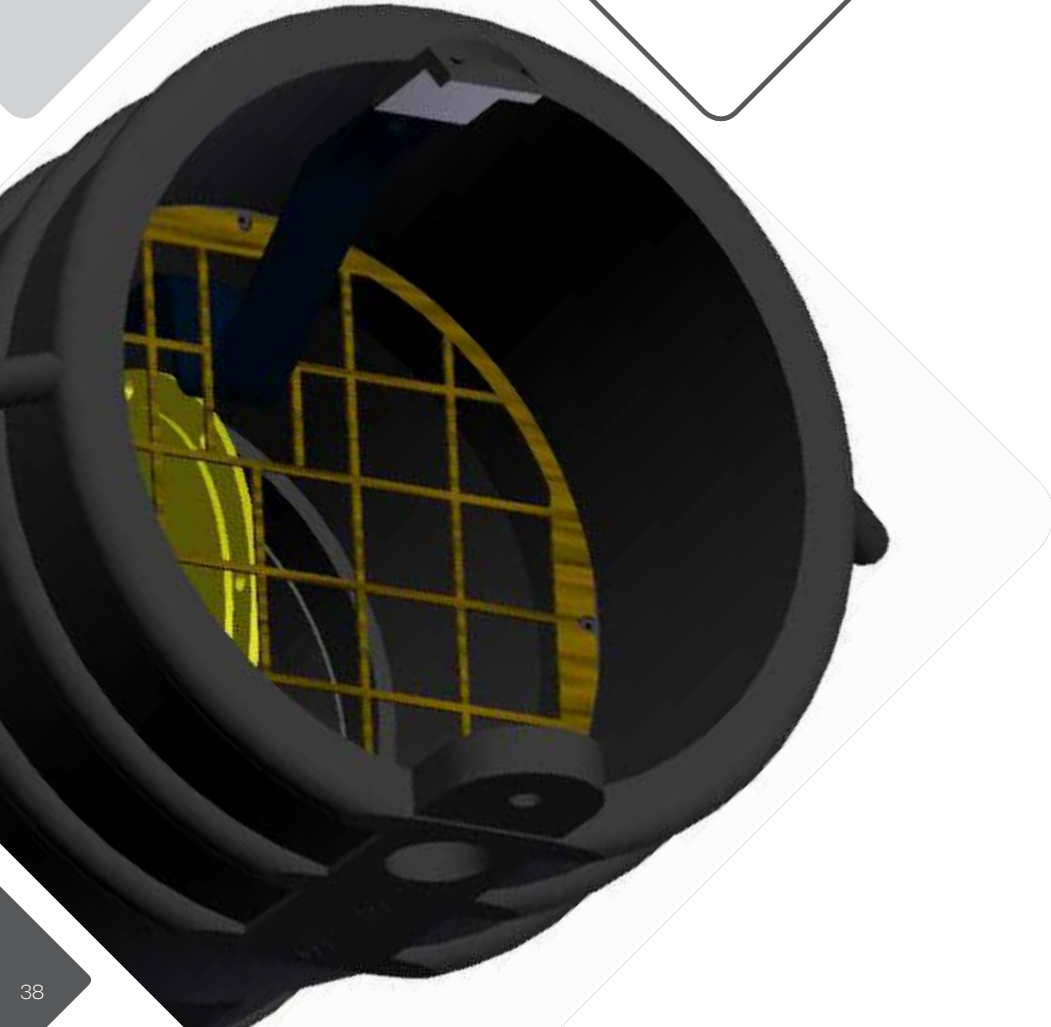

 Bocchetta in gomma per impieghi gravosi con rete anti intrusione, serranda a tenuta stagna inclusa nel corpo della bocchetta, clip di fissaggio al tubo di scarico e bocca di aspirazione da 185 mm.

 Heavy duty rubber nozzle with fully tight closing valve included in the body of the product, protection net, clip for fixing to the exhaust pipe and suction intake diam 185 mm.

 Entonnoir en caoutchouc pour PL avec soupape étanche inclus dans le corp du produit, réseau anti-intrusion, clip de fixation au pot d'échappement et bouche aspirante de 185 mm de diamètre.

 Gummitrichter für LKW mit Schutzgitter, dichter Absperrklappe im Trichterkörper integriert, Befestigungsclips und Saugmund DN 185 mm.

 Boquerel en goma para vehiculos pesados con rejilla anti-intrusión, tapa de cierre incluida en el cuerpo del producto, clip de fijación y boca de aspiración de 185 mm de diámetro.

cod.	IN	OUT	valv.	notes
GRTN-100K	185 mm	ø 100 mm	√	CLIP
GRTN-125K	185 mm	ø 125 mm	√	CLIP
GRTN-150K	185 mm	ø 150 mm	√	CLIP



via Masaccio, 15
42124 Reggio Emilia (RE) ITALY
Tel. +39 0522 1545193
vendite@worky-italy.com
sales@worky-italy.com

www.worky-italy.com

GRTN-K - technical datasheet

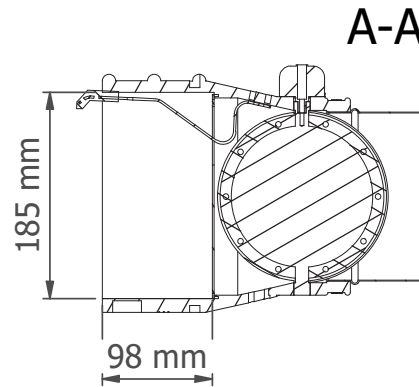
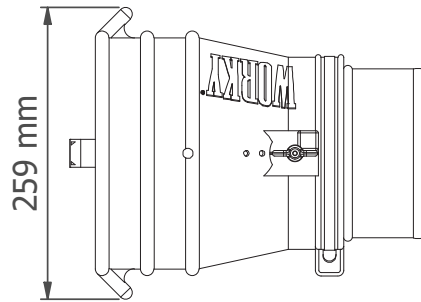
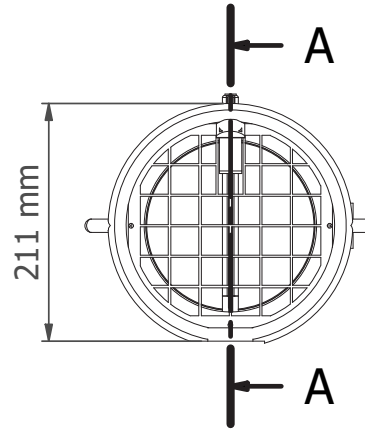
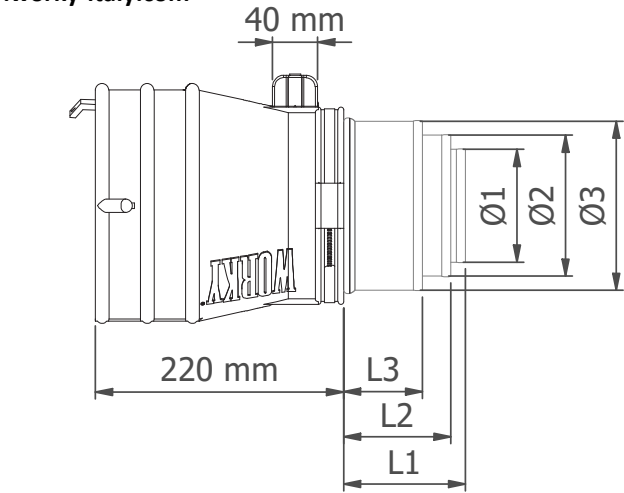

	COD	L [mm]	L Tot [mm]	Ø [mm]	PACK			Kg Tot
					l [mm]	w [mm]	h [mm]	
1	GRTN-100K	108	328	100	350	350	370	4
2	GRTN-125K	95	315	125	350	350	370	4
3	GRTN-150K	70	290	150	350	350	370	4

THIS DRAWING IS PROPERTY OF DEA + RO & Co S.p.A. THE COMPLETE OR PARTIAL REPRODUCTION OF THIS DOCUMENT IS FORBIDDEN. THE OWNER RESERVES THE RIGHT TO UPDATE, MODIFY OR AMEND ANY SPECIFICATION WITHOUT PRIOR NOTICE.

Rev.00

1/1
05/06/2024

GRTN-MG

 Bocchetta in gomma per impieghi gravosi con rete anti intrusione, serranda a tenuta stagna inclusa nel corpo della bocchetta, pinza gommata di fissaggio al tubo di scarico e bocca di 185 mm.

 Heavy duty rubber nozzle with fully tight closing valve included in the body of the product, protection net, vulcanized clamp for fixing to the exhaust pipe and suction intake diam 185 mm.

 Entonnoir en caoutchouc pour PL avec soupape étanche inclus dans le corp du produit, réseau anti-intrusion, pince vulcanisée de fixation au pot d'échappement et bouche aspirante de 185 mm de diamètre.

 Gummitrichter für LKW mit Schutzgitter, dichter Absperrklappe im Trichterkörper integriert, vulkanisierte Klemme und Saugmund DN 185 mm.

 Boquerel en goma para vehiculos pésados con rejilla anti-intrusión, tapa de cierre incluida en el cuerpo del producto, mordaza vulcanizada y boca de 185 mm de diámetro.

cod.	IN	OUT	valv.	notes
GRTN-100MG	185 mm	ø 100 mm	√	HD GRIP
GRTN-125MG	185 mm	ø 125 mm	√	HD GRIP
GRTN-150MG	185 mm	ø 150 mm	√	HD GRIP



WORKY

www.worky-italy.com

A brand of RO & Co S.p.A.
 via Masaccio, 15
 42124 Reggio Emilia (RE) ITALY
 Tel. +39 0522 1545193
 vendite@worky-italy.com
 sales@worky-italy.com

GRTN-MG - technical datasheet

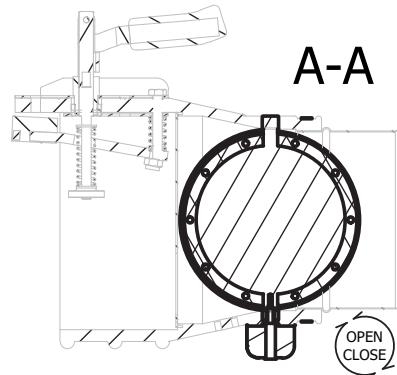
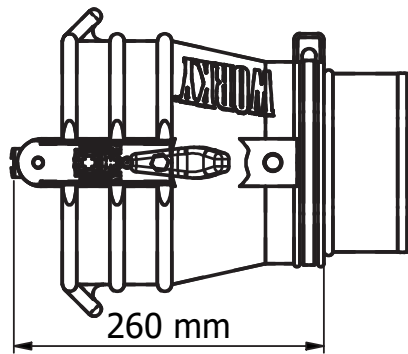
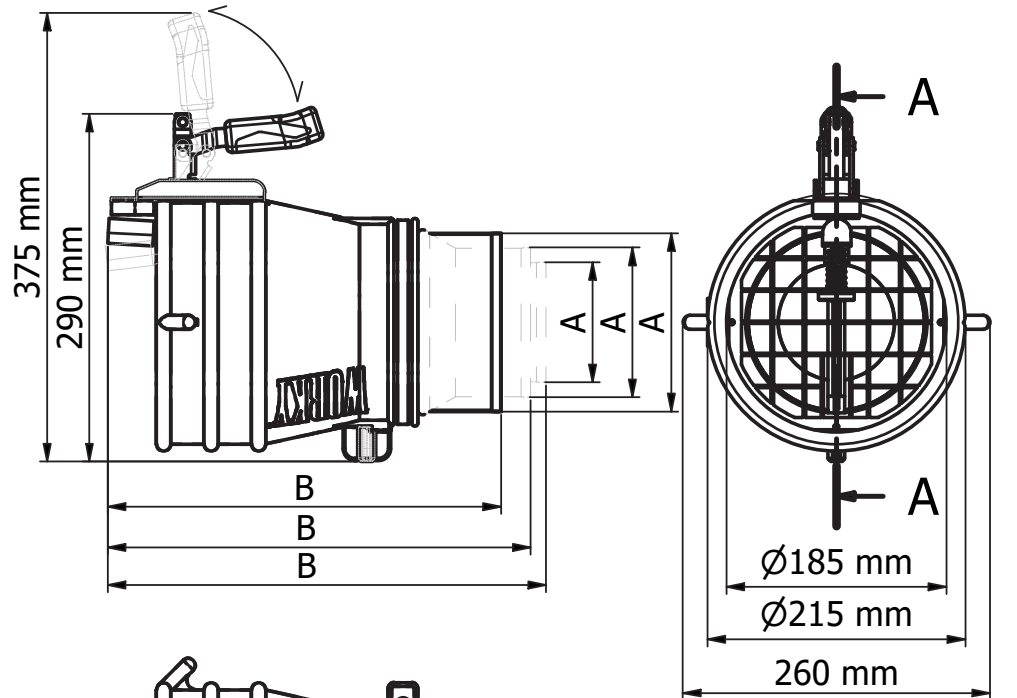

mm x x H

Kg 3

GRTN-MG	A Ø	B
GRTN-100MG	100 mm	369 mm
GRTN-125MG	125 mm	355 mm
GRTN-150MG	150 mm	330 mm

GRTN-EG

 Bocchetta in gomma per impieghi gravosi con pinza interna ad espansione e bocca di 185 mm.

 Heavy duty rubber nozzle with internal expanding clamp and suction intake diam 185 mm.

 Entonnoir en caoutchouc pour PL avec pince interne a expansion et bouche aspirante de 185 mm de diamètre.

 Gummitrichter für LKW mit Innenverbreitungsklemme und Saugöffnung DN 185 mm.

 Boquerel en goma para vehiculos pésados con rejilla anti-intrusión, tapa de cierre incluida en el cuerpo del producto, mordaza vulcanizada y boca de 185 mm de diámetro.

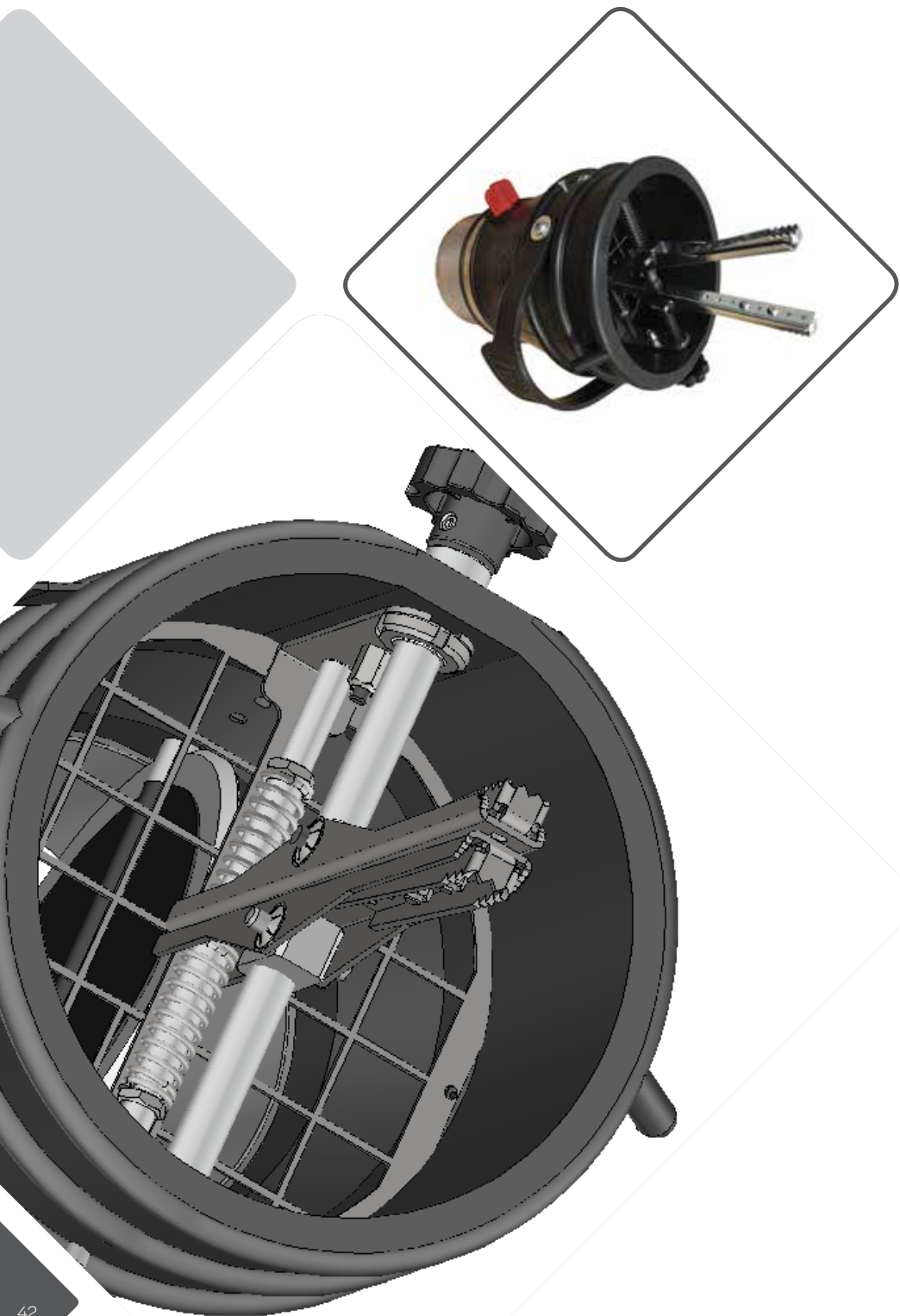

cod.	IN	OUT	valv.	notes
GRTN-100MG	185 mm	ø 100 mm	√	HD GRIP
GRTN-125MG	185 mm	ø 125 mm	√	HD GRIP
GRTN-150MG	185 mm	ø 150 mm	√	HD GRIP



www.worky-italy.com

A brand of RO & Co S.p.A.
 via Masaccio, 15
 42124 Reggio Emilia (RE) ITALY
 Tel. +39 0522 1545193
 vendite@worky-italy.com
 sales@worky-italy.com

GRTN-EG - technical datasheet

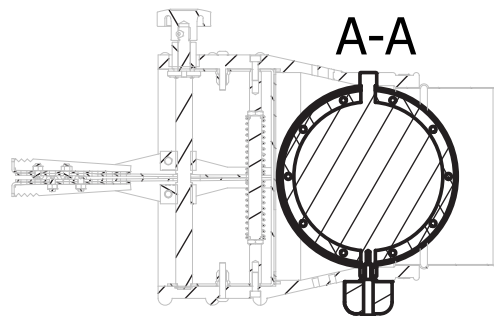
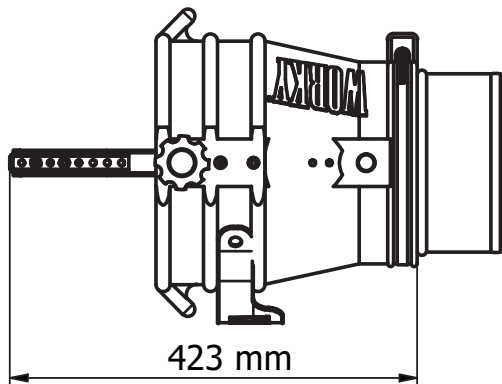
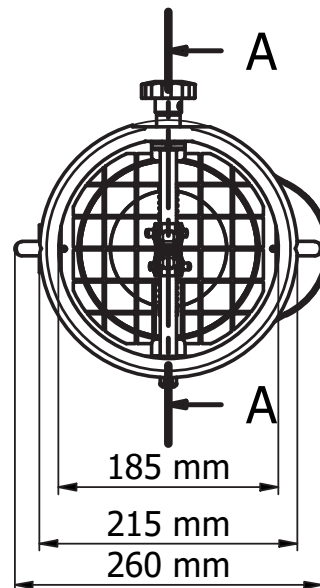
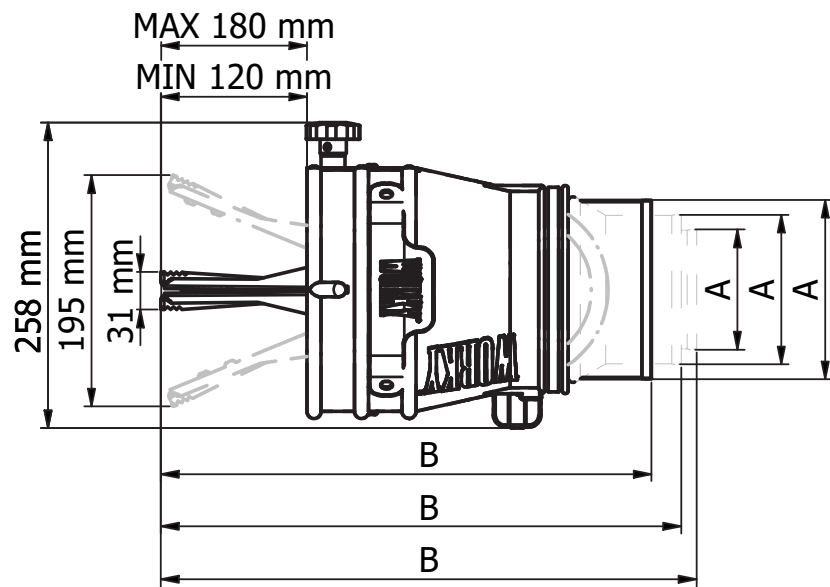

GRTN-EG	A Ø	B
GRTN-100EG	100 mm	450 mm
GRTN-125EG	125 mm	440 mm
GRTN-150EG	150 mm	415 mm



mm x x H

Kg 3

GMN

 Le bocchette in acciaio GMN (Gas Metal Nozzle) sono i prodotti più robusti e resistenti agli impieghi più gravosi nella gamma di WORKY. Ne fanno parte le bocchette con pinza, quelle carrellate e quelle per scarichi verticali, con particolare attenzione ai mezzi commerciali e movimento terra. Quando il gioco si fa duro, e l'applicazione si fa problematica, allora scendono in campo le bocchette GMN per attaccarsi agli scarichi più problematici e con caratteristiche più complesse. Non ti fermare alle apparenze, c'è sempre una soluzione alle tue necessità... anche alle più complesse. Affidati a WORKY.

 GMN (Gas Metal Nozzle) are the most robust and heavy-duty products in WORKY's range. They include gripper nozzles, wheeled nozzles and vertical stacks nozzles, with a focus on commercial and construction vehicles. When the going gets tough, and the application becomes problematic, then GMN nozzles come into play to attach to the most problematic situation with the most complex features. Don't stop at appearances, there is always a solution to your needs... even the most complex ones. Rely on WORKY.



 Les entonnoirs en acier GMN (Gas Metal Nozzle) sont les produits les plus robustes et les plus résistants de la gamme WORKY. Elles comprennent des versions à pince, des autres sur chariot et des entonnoirs pour échappements verticaux, en particulier pour les véhicules commerciaux et de construction. Lorsque les choses se corsent et que l'application devient problématique, les buses GMN entrent en jeu. Ne vous arrêtez pas aux apparences, il y a toujours une solution à vos besoins... même les plus complexes. Faites confiance à WORKY.

 GMN-Stahltrichtern (Gas Metal Nozzle) sind die robustesten und strapazierfähigsten Produkte im WORKY-Sortiment. Sie umfassen Greifertrichter, Wagenmontierte Trichtern und vertikale Auslasstrichtern, wobei der Schwerpunkt auf Nutz- und Baufahrzeugen liegt. Wenn es hart auf hart kommt und die Anwendung problematisch wird, dann kommen GMN-Trichtern ins Spiel, die an den problematischsten Abflüssen mit den komplexesten Eigenschaften angebracht werden können. Verlassen Sie sich auf WORKY

 Los boquereles de acero GMN (Gas Metal Nozzle) son los productos más robustos y resistentes de la gama WORKY. Incluyen versiones de agarre, otros con ruedas y boquereles para escapes verticales, con especial atención a los vehículos comerciales y de construcción. Cuando las cosas se ponen difíciles y la aplicación se vuelve problemática, entonces entran en juego los boquereles GMN para acoplarse a los tubos de escape más problemáticos. No se detenga en las apariencias, siempre hay una solución para sus necesidades... incluso las más complejas. Confíe en WORKY.

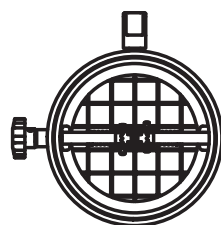

Ø150 mm

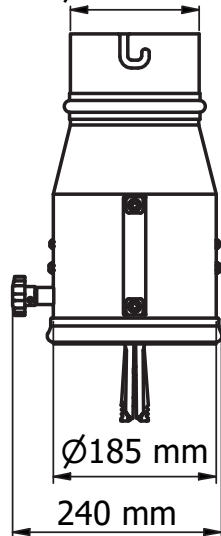

Ø185 mm

240 mm

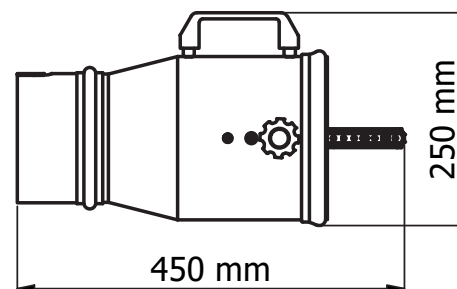

450 mm

250 mm

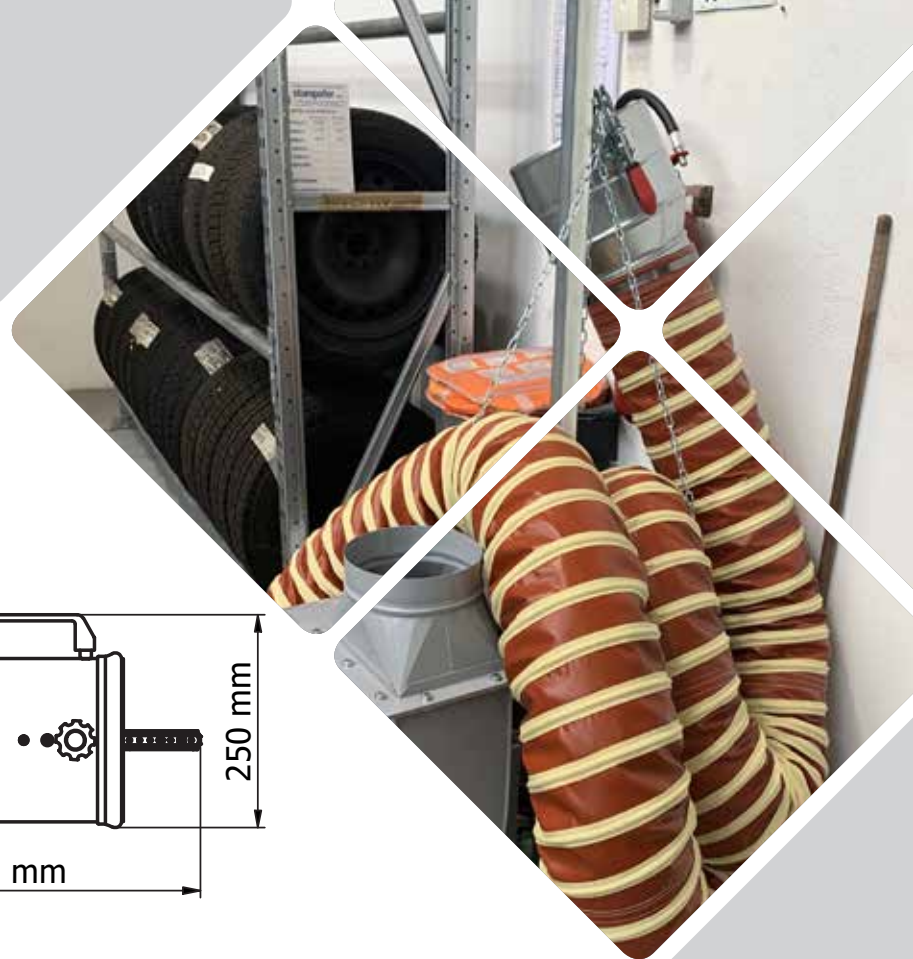



GMN



 Bocchetta in acciaio con paletta di chiusura

 Steel nozzle with closing flap

 Entonnoir en acier avec clapet de fermeture

 Stahltrichter mit Verschlussklappe

 Boquerel de acero con tapa de cierre



cod.	IN	OUT	valv.	notes
GMN-75	120 mm	ø 75 mm	flap	galvanized
GMN-100	100 mm	ø 100 mm	flap	galvanized
GMN-125	150 mm	ø 125 mm	flap	galvanized
GMG-150	150 mm	ø 150 mm	flap	galvanized



via Masaccio, 15
 42124 Reggio Emilia (RE) ITALY
 Tel. +39 0522 1545193
 vendite@worky-italy.com
 sales@worky-italy.com

www.worky-italy.com

GMN - technical datasheet

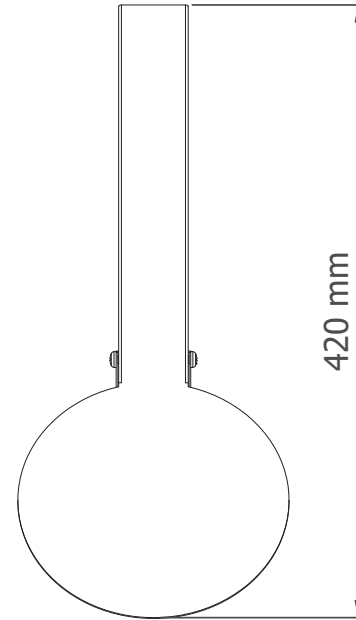
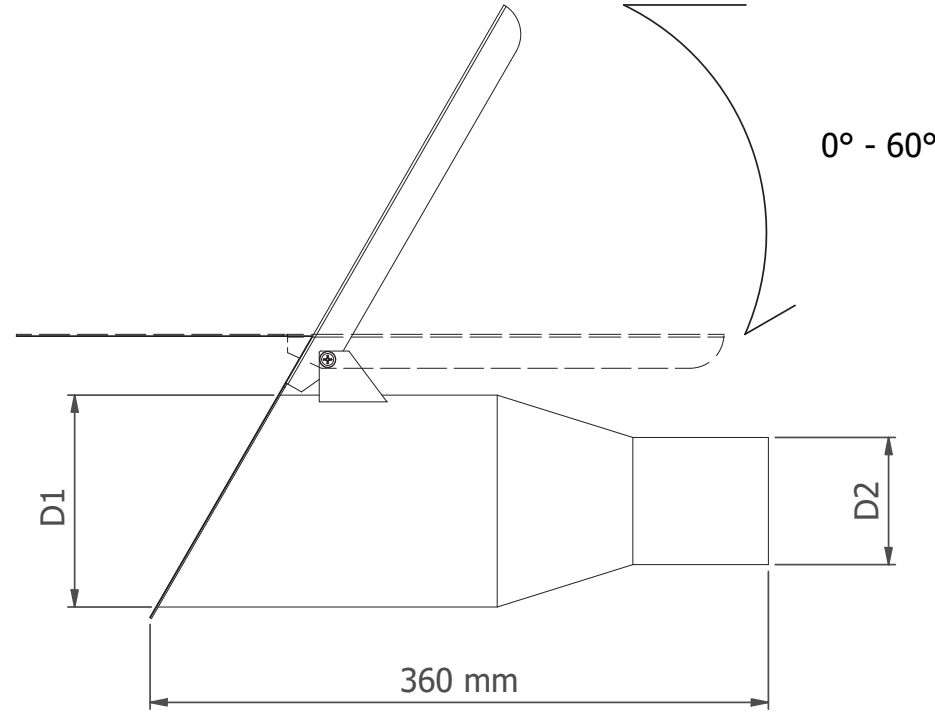

COD	D1 [mm]	D2 [mm]	PACK			Kg Tot
			l [mm]	w [mm]	h [mm]	
GMN-75	120	75	600	400	650	1.3
GMN-100	100	100	600	400	650	1.3
GMN-125	150	125	600	400	650	1.5
GMN-150	150	150	600	400	650	1.5

THIS DRAWING IS PROPERTY OF DEA + RO & Co S.p.A. THE COMPLETE OR PARTIAL REPRODUCTION OF THIS DOCUMENT IS FORBIDDEN. THE OWNER RESERVES THE RIGHT TO UPDATE, MODIFY OR AMEND ANY SPECIFICATION WITHOUT PRIOR NOTICE.

Rev.00

1/1
 08/11/2024

GMNG

 Bocchetta in acciaio mm con pinza manuale di tenuta.

 Steel nozzle with manual gripper.

 Entonnoir en acier avec pince étau.

 Stahltrichter mit Klemmzange.

 Boquerel de acero con pinza.



cod.	IN	OUT	valv.	notes
GMNG-100	200 mm	ø 100 mm	-	galvanized
GMNG-125	200 mm	ø 125 mm	-	galvanized
GMNG-150	200 mm	ø 150 mm	-	galvanized
GMNG-200	200 mm	ø 200 mm	-	galvanized
GMNG-250150	250 mm	ø 150 mm	-	galvanized
GMNG-250200	250 mm	ø 200 mm	-	galvanized
GMNG-250-45	250 mm	ø 250 mm	-	45° bend

WORKY

www.worky-italy.com

A brand of RO & Co S.p.A.
via Masaccio, 15
42124 Reggio Emilia (RE) ITALY
Tel. +39 0522 1545193
vendite@worky-italy.com
sales@worky-italy.com

GMNG - technical datasheet

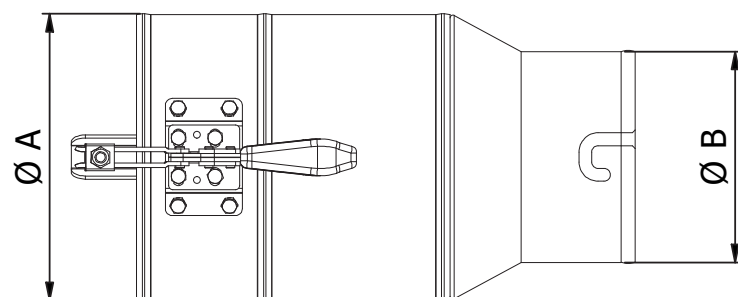
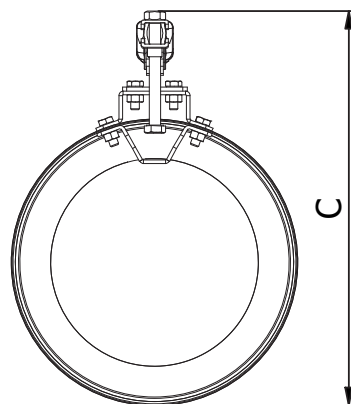
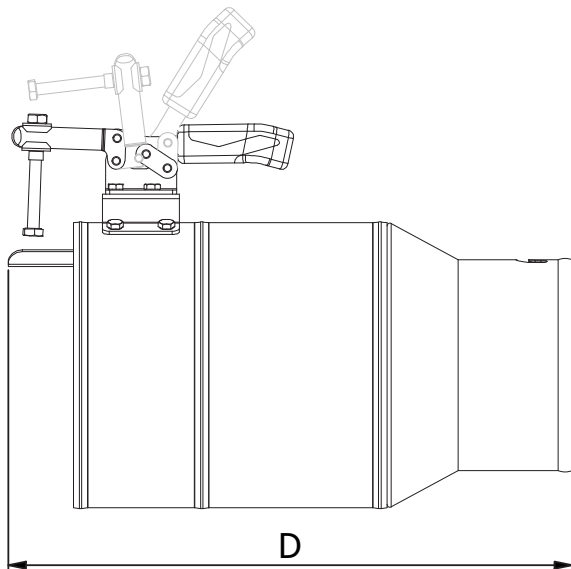

COD.	A [mm]	B [mm]	C [mm]	D [mm]	QUICK COUPLING
GMNG-100	200	100	275	395	/
GMNG-125	200	125	275	395	/
GMNG-150	200	150	275	395	√
GMNG-200	200	200	275	265	/
GMNG-250150	250	150	333	366	√
GMNG-250200	250	200	333	346	/



mm 400 x 500 x H 520

Kg 2

THIS DRAWING IS PROPERTY OF RO & Co S.p.A. THE COMPLETE OR PARTIAL REPRODUCTION OF THIS DOCUMENT IS FORBIDDEN. THE OWNER RESERVES THE RIGHT TO UPDATE, MODIFY OR AMEND ANY SPECIFICATION WITHOUT PRIOR NOTICE.

Rev.01

1/1
28/08/2023

GMN-MAG

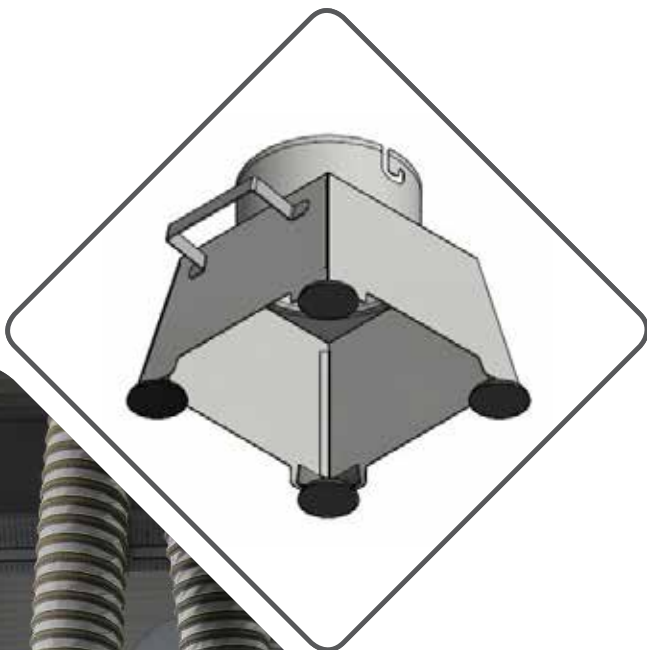

 Bocchetta quadra in metallo con magneti, maniglie di movimentazione e predisposizione per sgancio rapido dal tubo.

 Square metal nozzle with magnets, handling handles and provision for quick release from the hose.

 Entonnoir métallique carrée avec aimants, poignées et dispositif de détachement rapide du flexible.

 Quadratische Metalltrichter mit Magneten, Handgriffen und einer Vorrichtung zum schnellen Lösen vom Schlauch.

 Boquerel metálico cuadrado con imanes, asas de manejo y disposición para una rápida liberación del tubo.

cod.	IN	OUT	valv.	notes
GMN-150MAG	210 X 210 mm	ø 150 mm	-	GSR-F
GMN-200MAG	260 X 260 mm	ø 200 mm	-	GSR-F





via Masaccio, 15
 42124 Reggio Emilia (RE) ITALY
 Tel. +39 0522 1545193
 vendite@worky-italy.com
 sales@worky-italy.com

www.worky-italy.com

GMN-MAG - technical datasheet

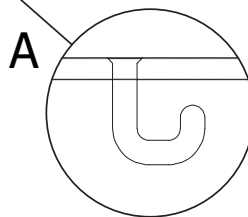
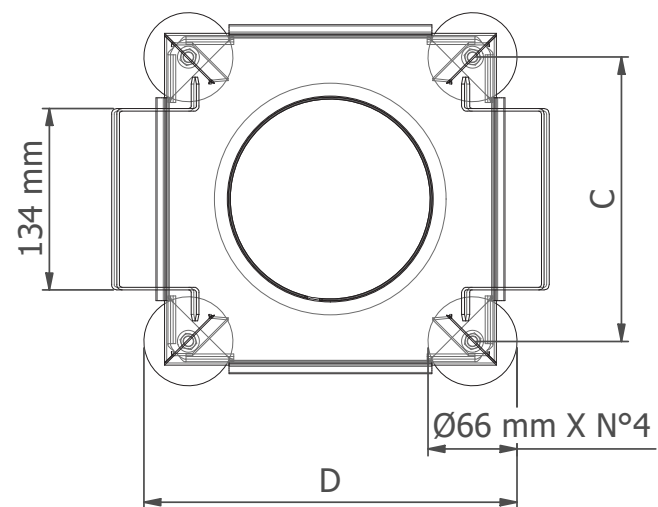
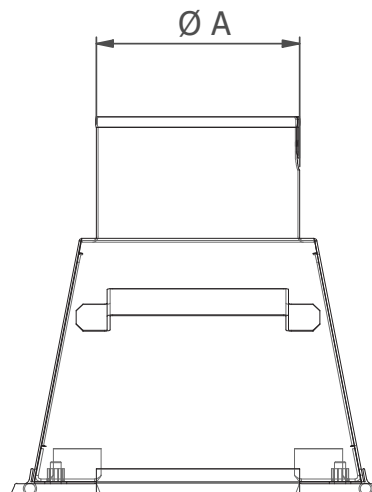
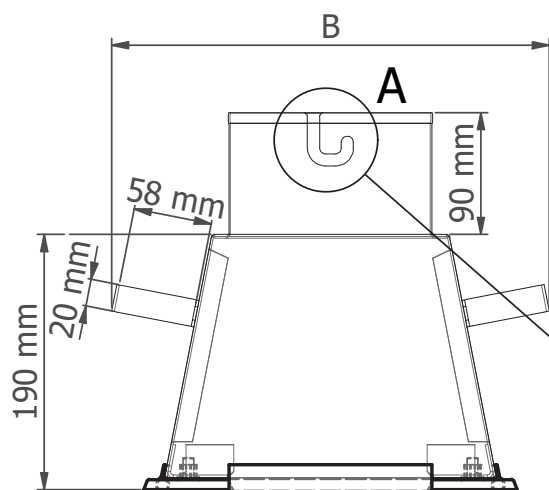

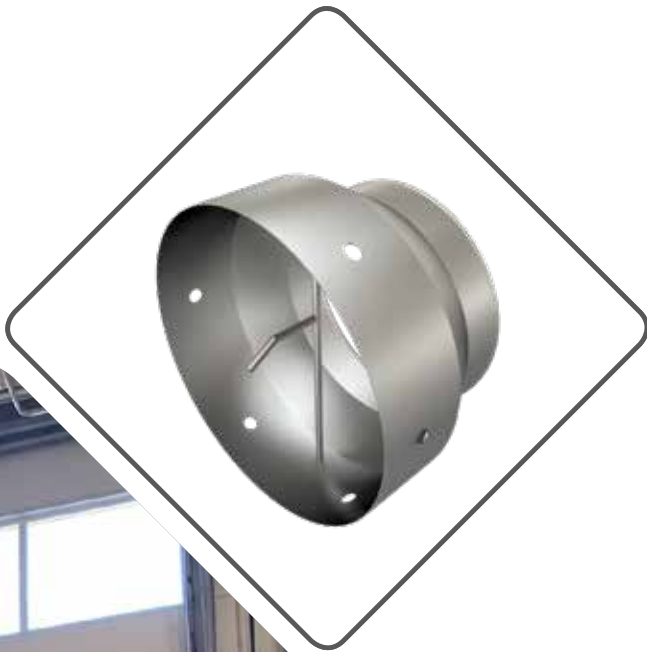

COD.	A [mm]	B [mm]	C [mm]	D [mm]
GMN-150MG	150	323	210	276
GMN-200MG	200	365	260	327





GMN-500400H

 Bocchetta rotonda in acciaio per tubo flessibile con diametro di 400 mm e apertura di 500 mm con asta di centraggio per scarichi verticali e piccoli fori intorno per far entrare l'aria fresca.

 Steel round nozzle for hose diam 400 mm and opening 500 mm with centering rod for vertical stacks and little holes around to let fresh air in.

 Entonnoir ronde en acier pour flexible de 400 mm de diamètre et 500 mm d'ouverture avec tige de centrage pour les pots d'échappement verticales et petits trous autour pour laisser entrer l'air de refroidissement.

 Rundtrichter aus Stahl für Schlauchdurchmesser 400 mm und Öffnung 500 mm mit Zentrierstab für vertikale Auspuffrohre und kleinen Löchern rundherum, um Frischluft einzulassen.

 Boquerel redondo de acero para manguera de 400 mm de diámetro y 500 mm de abertura con varilla de centrado para escapes verticales y pequeños orificios alrededor para dejar entrar aire fresco.

cod.	IN	OUT	valv.	notes
GMN-500400H	ø 500 mm	ø 400 mm	-	-







via Masaccio, 15
42124 Reggio Emilia (RE) ITALY
Tel. +39 0522 1545193
vendite@worky-italy.com
sales@worky-italy.com

www.worky-italy.com

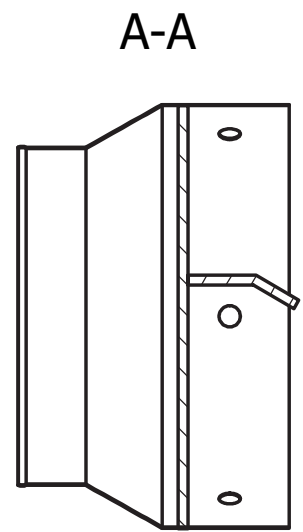
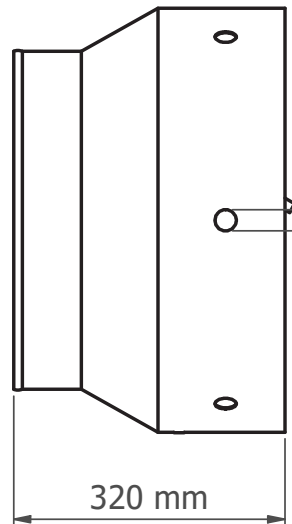
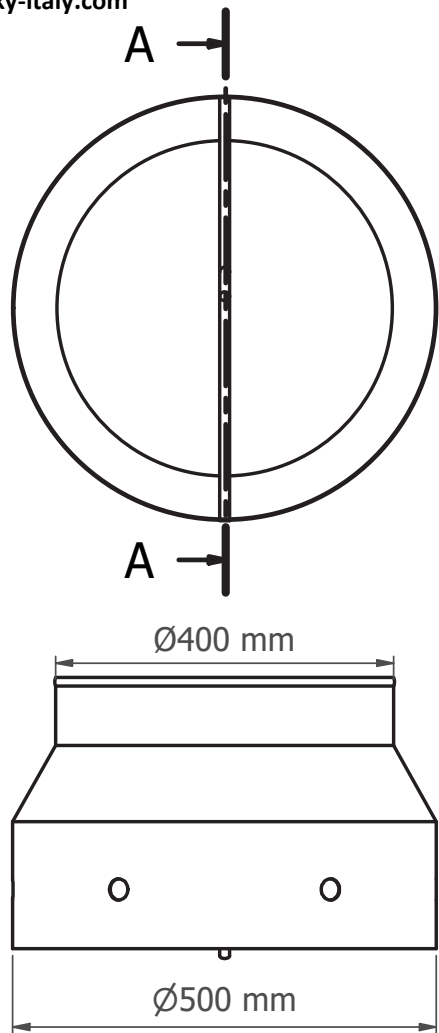
GMN-500400H - technical datasheet





 mm x x H
kg

THIS DRAWING IS PROPERTY OF DEA + RO & Co S.p.A. THE COMPLETE OR PARTIAL REPRODUCTION OF THIS DOCUMENT IS FORBIDDEN. THE OWNER RESERVES THE RIGHT TO UPDATE, MODIFY OR AMEND ANY SPECIFICATION WITHOUT PRIOR NOTICE.

GMNCV



 Bocchetta diam 200 mm in acciaio zincato con curva a 45° con maniglia e serranda di chiusura integrata.

 Galvanized steel nozzle diam 200 mm with 45° bend, handle and integrated closing valve.

 Entonnoir en acier galvanisé diam. 200 mm avec coude a 45° et registre intégré.

 Stahltrichter DN 200 mm mit 45° Bogen und integrierter Absperrklappe.

 Boquerel de acero galvanizado diam. 200 mm con curva de 45° y manija con tapa de cierre integrado.



cod.	IN	OUT	valv.	notes
GMNCV-150	200 mm	ø 150 mm	√	-
GMNCV-200	200 mm	ø 200 mm	√	-



A brand of RO & CO S.p.A
via Masaccio, 15
42124 Reggio Emilia (RE) ITALY
Tel. +39 0522 1545193
Fax +39 0522 1546451
vendite@worky-italy.com
sales@worky-italy.com
www.worky-italy.com

GMNCV150_technical_datasheet

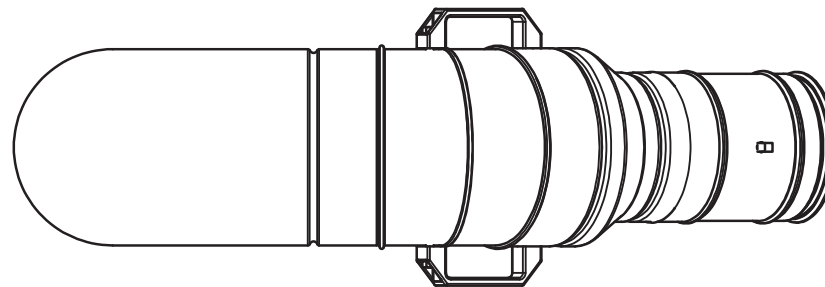
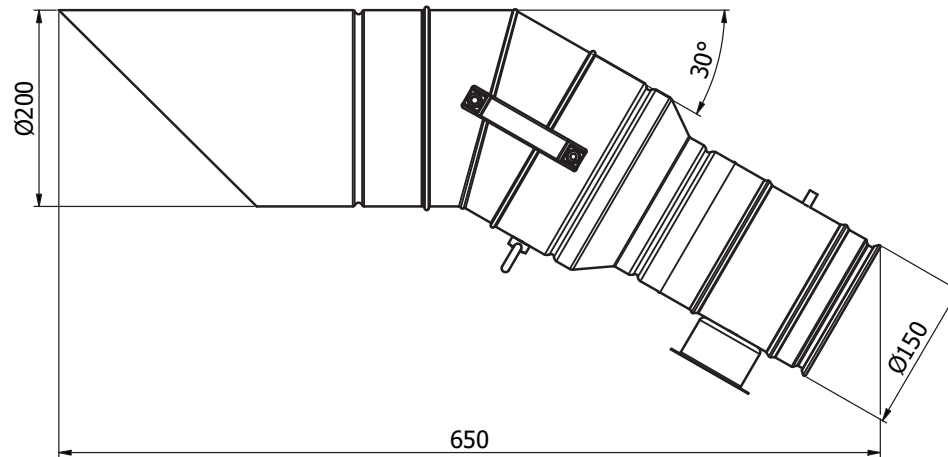
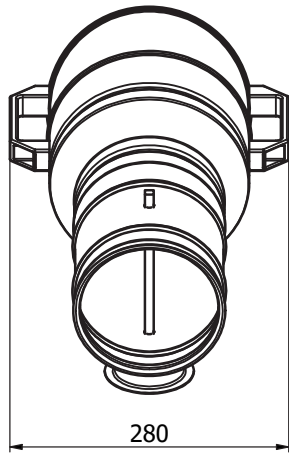

GMN-EG



 Bocchetta in acciaio con pinza interna ad espansione e raccordo tubo con attacco a baionetta.

 Steel nozzle with internal expansion gripper and hose connection with bayonet coupling.

 Entonnoir en acier avec pince d'expansion interne et raccord a baïonnette au flexible.

 Stahlblechtrichter mit innenliegender Spreizzange und Schlauchanschluss mit Bajonettkupplung.

 Boquerel de acero con pinza de expansión interna y conexión de manguera con acoplamiento de bayoneta.

cod.	IN	OUT	valv.	notes
GMN-100EG	185 mm	ø 100 mm	-	GSR-F
GMN-125EG	185 mm	ø 125 mm	-	GSR-F
GMN-150EG	185 mm	ø 150 mm	-	GSR-F

GMN-150EG - technical datasheet

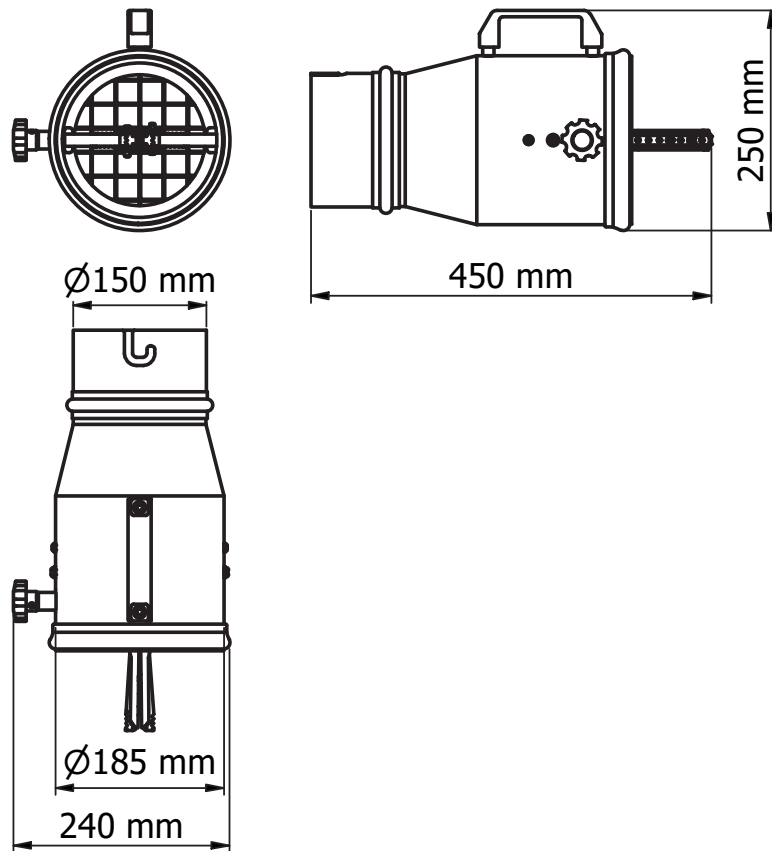



mm x x H

Kg 3

GMNVE

 Bocchetta pastorale in lamiera zincata dotata di maniglie di movimentazione, cappetta con perno di posizionamento per aspirazione da tubi di scarico verticali.

 Galvanized sheet steel nozzle suitable to extract from vertical stacks and equipped with internal pin for matching the exhaust pipe and 2 handles for easier positioning.

 Entonnoir en tôle d'acier galvanisée apte à l'extraction des gaz des pots d'échappement verticaux. Il est équipé d'une greffe interne et 2 poignées pour faciliter le positionnement.

 Senkrechter verzinkter Blechtrichter mit Halterungsgriffen, Kappe mit Positionierstift zum Absaugen von senkrechten Auspuffrohren.

 Boquerel vertical para tubos de escape al techo con dispositivo de posicionamiento y manijas de manipulación.

cod.	IN	OUT	valv.	notes
GMNVE-125	250 mm	ø 125 mm	-	GSR-F
GMNVE-150	250 mm	ø 150 mm	-	GSR-F





www.worky-italy.com

A brand of RO & Co S.p.A.
via Masaccio, 15
42124 Reggio Emilia (RE) ITALY
Tel. +39 0522 1545193
vendite@worky-italy.com
sales@worky-italy.com

GMNVE-150 - technical datasheet

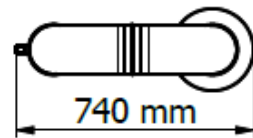
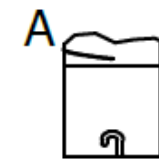
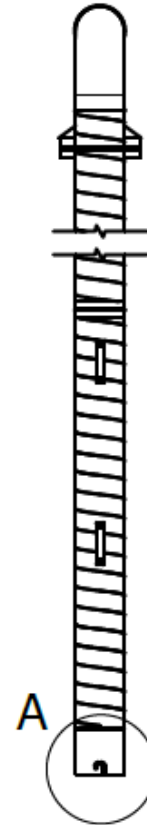
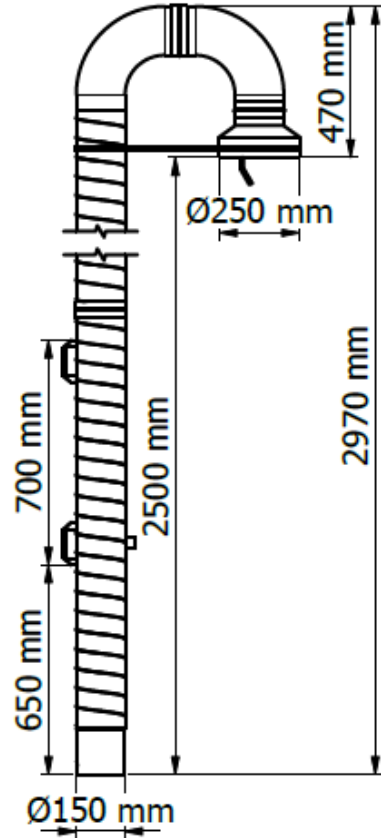

mm x x H
Kg

THIS DRAWING IS PROPERTY OF RO & Co S.p.A. THE COMPLETE OR PARTIAL REPRODUCTION OF THIS DOCUMENT IS FORBIDDEN. THE OWNER RESERVES THE RIGHT TO UPDATE, MODIFY OR AMEND ANY SPECIFICATION WITHOUT PRIOR NOTICE.

Rev.00

1/1

03/09/2021





GMNP

 Bocchetta sport in metallo agganciata magneticamente al piedistallo anch'esso con base magnetica per essere facilmente scollegato e fissato al ponte sollevatore.

 Metal sports nozzle magnetically attached to the pedestal, which also has a magnetic base so it can be easily detached and attached to the lifting platform.

 Entonnoir sportif en métal fixée magnétiquement au piédestal, qui dispose également d'une base magnétique permettant de la détacher et de la fixer facilement au pont élévateur.

 Sporttrichter aus Metall, die magnetisch am Sockel befestigt ist, der auch einen Magnetfuß hat, so dass er leicht abgenommen und an der Hebebühne befestigt werden kann.

 Boquerel deportivo metálico fijada magnéticamente al pedestal, que también tiene una base magnética para poder separarla y fijarla fácilmente al puente elevador.

cod.	IN	OUT	valv.	notes
GMNP-100SPORT	450 X 260 mm	ø 100 mm	-	Magnetic fix.
GMNP-150SPORT	450 X 260 mm	ø 150 mm	-	Magnetic fix.



www.worky-italy.com

via Masaccio, 15
42124 Reggio Emilia (RE) ITALY
Tel. +39 0522 1545193
vendite@worky-italy.com
sales@worky-italy.com

GMNP-100SPORT - technical datasheet

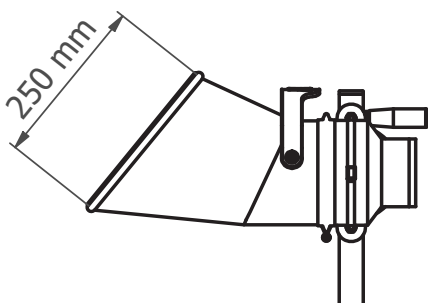
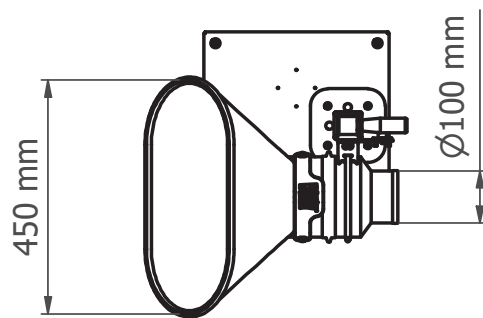
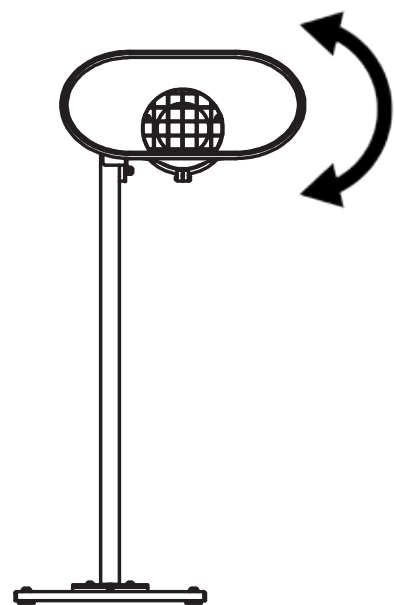
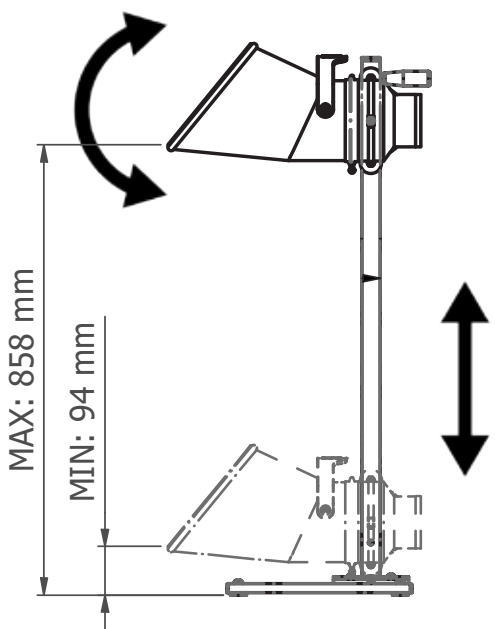
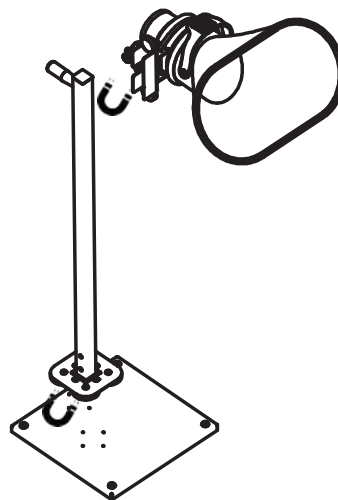

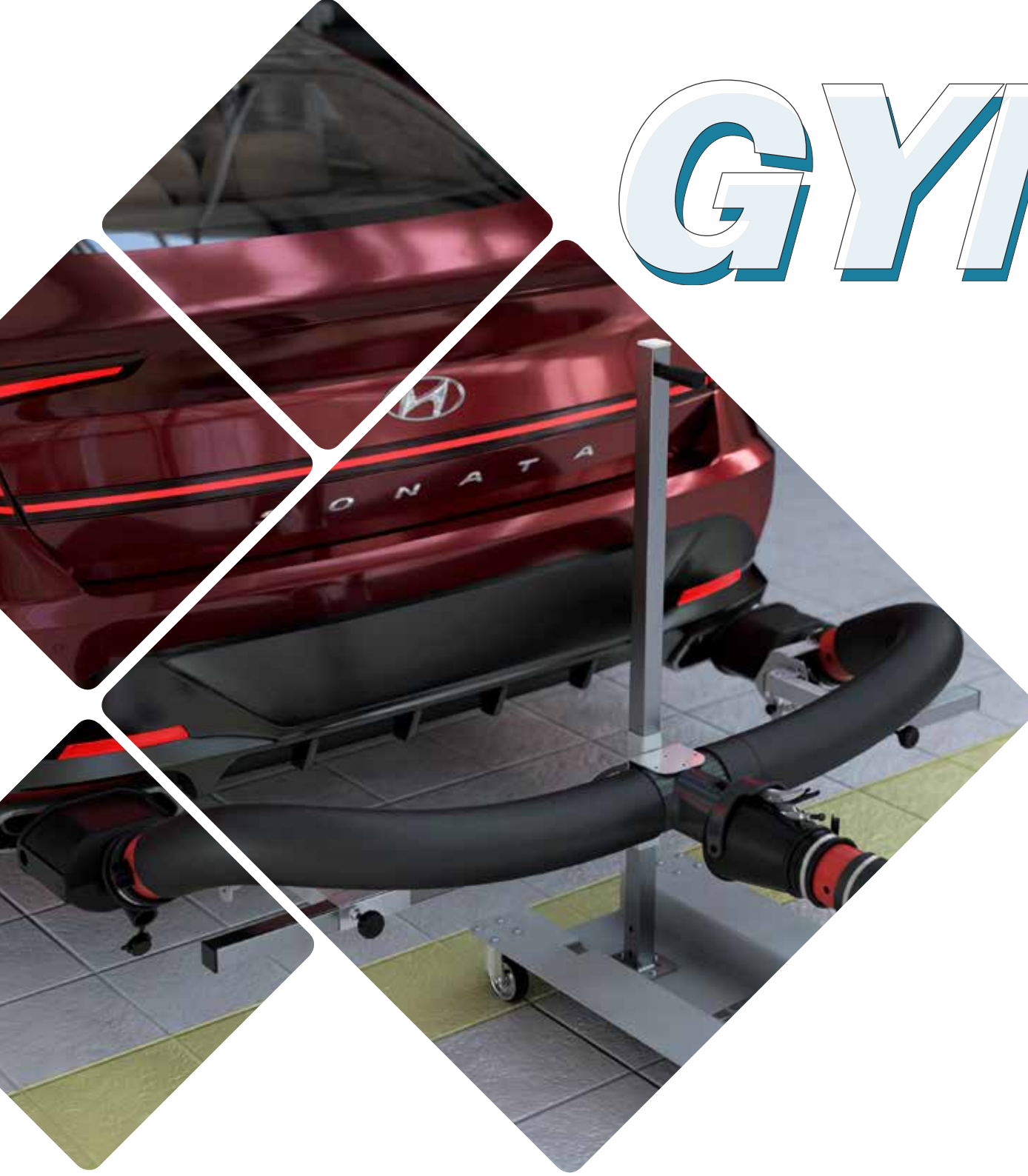

GYNMA



 Le bocchette doppie della serie GYNMA montate su carrello offrono una soluzione universale e senza contatto con la vettura. Il fatto di essere montate su carrello ne permette una facile movimentazione e la multiregolazione che offrono i braccetti orientabili fornisce una flessibilità unica nel suo genere. GYNMA offre diverse bocche di aspirazione, diametri e resistenza alle temperature. Ora aspirare da vetture con il doppio scarico non sarà più un problema, GYNMA si adatta a qualsiasi veicolo e riesce a collegarsi agli impianti esistenti con tubo singolo. Il carrello ergonomico e la facilità di utilizzo fanno di GYNMA la bocchetta universale per tutte le auto o moto.

 The GYNMA double nozzles mounted on the trolley offer a universal and contactless solution for every car. The fact that it is mounted on a trolley allows an easy handling and the multi-regulation offered by the adjustable armlets provides a unique flexibility of its kind. GYNMA offers several configurations, diameters and temperature resistance. Now extracting the exhaust gas from double silencer's cars will no longer be a problem, GYNMA fits to any vehicle and can get connected to existing single pipe systems. The ergonomic trolley and friendly application make GYNMA the universal nozzle for all cars or motorbikes.

 Les double entonnoirs de la série GYNMA montés sur le chariot offrent une solution universelle et sans contact pour aspirer les gaz d'échappement de chaque voiture. Le fait qu'il soit monté sur un chariot permet une manipulation facile et la multi-régulation offerte par les bras réglables offre une flexibilité unique en son genre. GYNMA offre plusieurs configurations des entonnoirs, des diamètres et de résistance à la température. Maintenant, l'extraction des gaz d'échappement des voitures à double pot d'échappement ne sera plus un problème, GYNMA s'adapte à n'importe quel véhicule et peut se connecter aux systèmes existants. Le chariot ergonomique et l'application facile font de GYNMA la solution universelle pour toutes les voitures ou motos.

 Die Wagen-montierten GYNMA Doppeldüsen bieten für jedes Auto eine universelle und berührungslose Lösung. Die Tatsache, dass es auf einem Trolley montiert ist, ermöglicht eine einfache Bewegung und die Multi-Regulierung durch die verstellbaren Armbänder bietet eine einzigartige Flexibilität seiner Art. GYNMA bietet mehrere Konfigurationen, Durchmesser und Temperaturbeständigkeit. Jetzt entnimmt das Abgas von Doppelschalldämpfer-Autos kein Problem mehr, GYNMA passt zu jedem Fahrzeug und kann an bestehende Einzelrohrsysteme angeschlossen werden. Der ergonomische Wagen und die einfache Anwendung macht GYNMA zur Universaldüse für alle Autos und Motorrad.

 Los boqueras dobles GYNMA montados en el carrito ofrecen una solución universal y sin contacto para la aspiración de los gases de escape desde cada coche. El hecho de que esté montado en un carro permite un manejo fácil y la multi-regulación ofrecida por los brazos ajustables proporciona una flexibilidad única de su tipo. GYNMA ofrece varias configuraciones, diámetros y resistencias a la temperatura. Ahora la extracción de los gases de escape de los coches de doble escape ya no será un problema, GYNMA se adapta a cualquier vehículo y puede conectarse a los sistemas existentes de tubería única. El carrito ergonómico y la aplicación sencilla hacen de GYNMA el boquerel universal para todos los coches o motos.



GYNMAG



 Bocchetta carrellata per scarichi doppi, completa di bivio ad Y predisposto per l'attacco rapido alla bocchetta GRNG, 2 tubi lunghi 1,25m, fascette e 2 bocchette in gomma GRN montate su aste indipendenti e pluri-regolabili.

 Trolley mounted nozzle for double exhaust pipes, complete with Y piece suitable for a quick connection to the GRNG nozzle, two hoses 1,25 mt long each, clamps and two rubber nozzles model GRN mounted on independently adjustable armlets.

 Entonnoir double sur chariot pour vehicules avec double échappement équipé avec un Y pour le raccord rapide avec l'entonnoir GRNG, 2 flexibles de 1,25 m et deux entonneurs en caoutchouc mod. GRN montés sur bras multi-réglables.

 Wagenmontierte Doppeltrichter für Fahrzeuge mit doppeltem Auspuff. Ausgestattet mit Y-Auslenkung als Schnellkupplung mit GRNG Trichter. 2 Schläuchen 1,25 m lang und zwei Gummi-Trichter mod. GRN auf verstellbaren, unabhängigen Armen montiert.

 Doble boquerel con carro para vehículos con escape doble equipado con desvío en Y para la conexión rápida con el boquerel GRNG, 2 mangueras de 1,25 m cada una y dos boquereles en goma mod. GRN sobre brazos multi-regulables.

cod.	IN	OUT	valv.	notes
GYNMAG-100100100	2 X ø 160 mm	ø 100 mm	√	QUICK GRNG

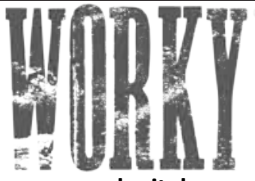

www.worky-italy.com

via Masaccio, 15
42124 Reggio Emilia (RE) ITALY
Tel. +39 0522 1545193
vendite@worky-italy.com
sales@worky-italy.com

GYNMAG-100100100 - technical datasheet

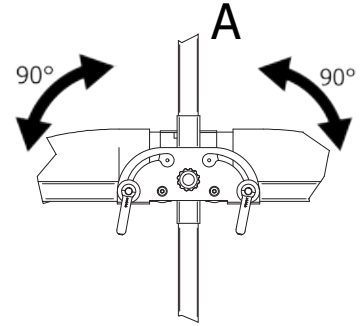
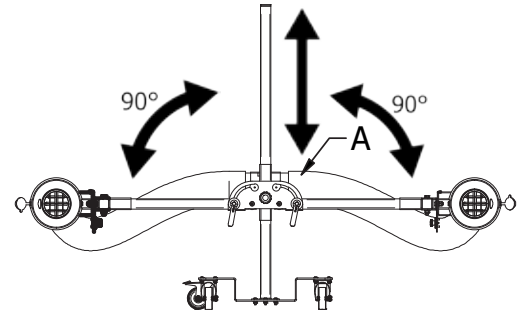
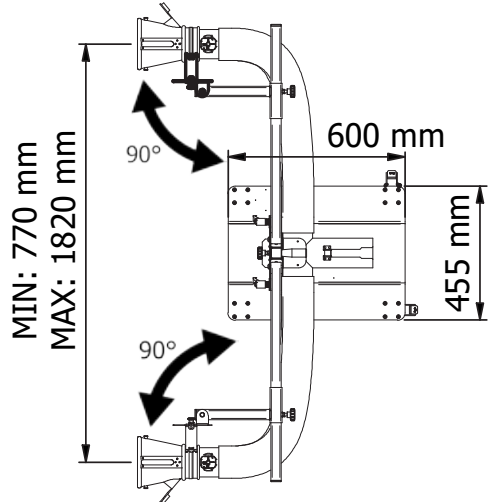
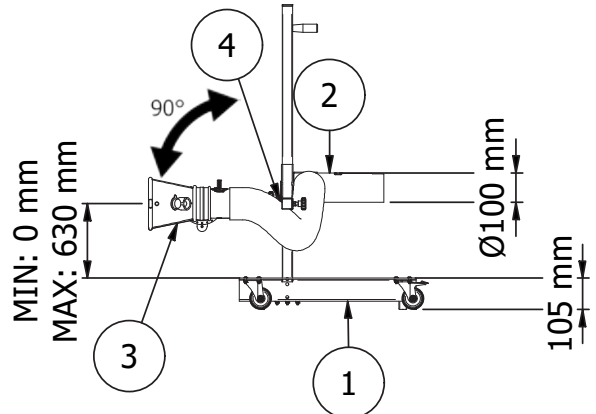

POS.	QTÀ	NUMERO PARTE
1	1	GYNMA-WN
2	1	607.12.012.0 + 700.16.003.2
3	2	GRN-160100_DX
4	2	GT2-100.1.25

GRN-100

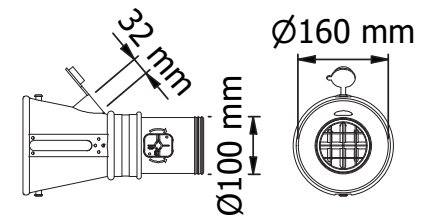

Rev.01

1/1
26/10/2022

THIS DRAWING IS PROPERTY OF RO & Co S.p.A. THE COMPLETE OR PARTIAL REPRODUCTION OF THIS DOCUMENT IS FORBIDDEN. THE OWNER RESERVES THE RIGHT TO UPDATE, MODIFY OR AMEND ANY SPECIFICATION WITHOUT PRIOR NOTICE.

GYNMAG-GON



 Bocchetta carrellata per scarichi doppi, completa di bivio ad Y, 2 tubi lunghi 1,25m, fascette e 2 bocchette ovali mod. GON montate su aste indipendenti e pluri-regolabili.

 Trolley mounted nozzle for double exhaust pipes, complete with Y piece, two hoses 1,25 mt long each, clamps and two oval nozzles model GON mounted on independently adjustable armlets.

 Entonnoir double sur chariot pour vehicules avec double échappement. Equipé avec une déviation à Y avec 2 flexibles de 1,25 m chacun et deux entonnoirs ovales mod. GON montés sur bras indépendents multi-réglables.

 Wagenmontierte Doppeltrichter für Fahrzeuge mit doppeltem Auspuff. Ausgestattet mit Y-Auslenkung mit je 2 Schläuchen 1,25 m lang und zwei Ovaler-Trichter mod. GON auf mehrfach verstellbaren, unabhängigen Armen montiert.

 Doble boquerel con carro para vehículos con escape doble. Equipado con desvio en Y con 2 mangueras de 1,25 m cada una y dos boquereles ovales mod. GON sobre brazos multi-regulables.

cod.	IN	OUT	valv.	notes
GYNMAG -GON100	2 X 210 X 105 mm	ø 100 mm	√	QUICK GRNG



www.worky-italy.com

A brand of RO & Co S.p.A.
 via Masaccio, 15
 42124 Reggio Emilia (RE) ITALY
 Tel. +39 0522 1545193
 vendite@worky-italy.com
 sales@worky-italy.com

GYNMAG-GON100 - technical datasheet

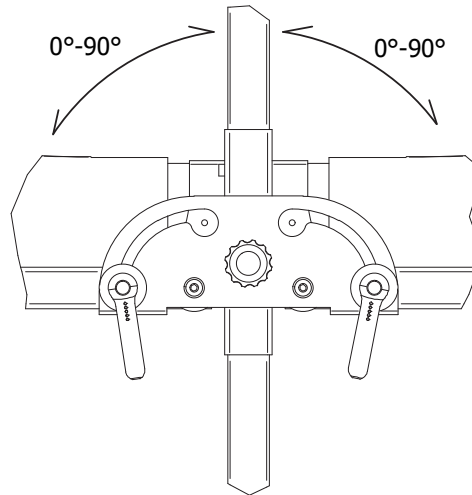
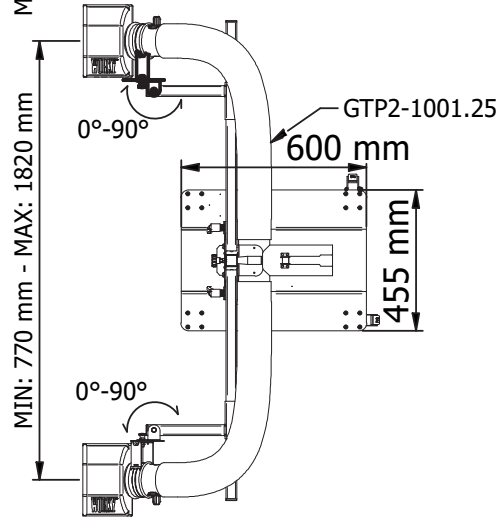
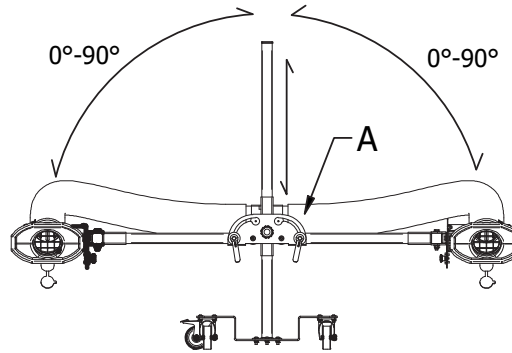
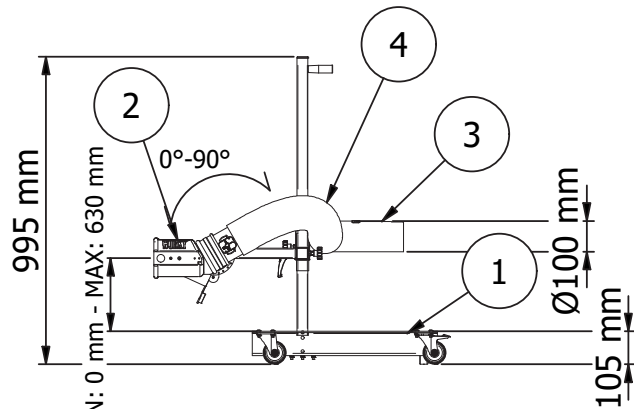
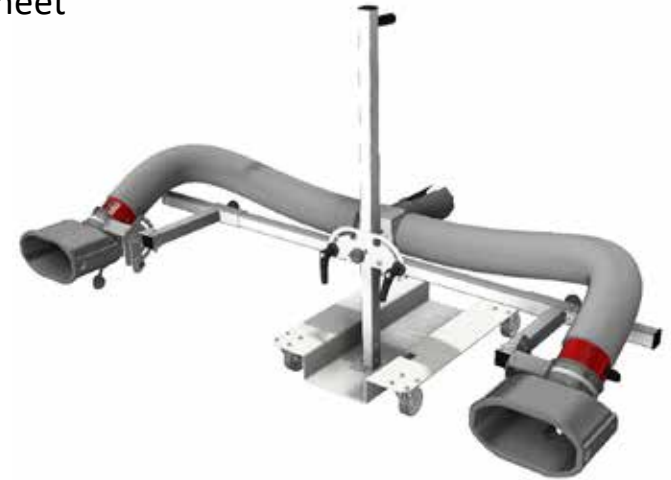

POS.	QNT	CODE
1	1	GYNMA-WN
2	2	GON-100
3	1	607.12.012.0 + 700.16.003.2
4	2	GTP2-1001.25

GON-100

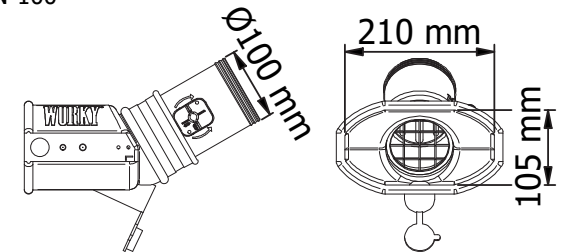

mm x x H

Kg 27

THIS DRAWING IS PROPERTY OF RO & Co S.p.A. THE COMPLETE OR PARTIAL REPRODUCTION OF THIS DOCUMENT IS FORBIDDEN. THE OWNER RESERVES THE RIGHT TO UPDATE, MODIFY OR AMEND ANY SPECIFICATION WITHOUT PRIOR NOTICE.

Rev.00

14/06/2021

GYNMAOG-GON



 Bocchetta carrellata per scarichi doppi, completa di bivio ad y con attacco rapido per bocchetta ovale, 2 tubi flessibil \varnothing 100 mm lungh.1,25m e 2 bocchette GON-100 su braccetti di supporto pluri-regolabili.

 Trolley mounted set for double exhaust pipe equipped with y piece for quick connection to rubber nozzle GON, two x 1,25-m-long hoses and two GON-100 nozzles mounted on tilting arms for perfect positioning behind the vehicle.

 Double entonnoir sur chariot pour double pot d'échappement, complet de jonction en Y avec raccord rapide pour entonnoir GON, 2 flexibles \varnothing 100 mm de 1,25 m de long. et 2 entonneirs GON-100 sur bras de support multi-réglables.

 Behrungsloser wagenmontierter trichter für doppelauspuffrohre komplett mit y stück für direktverbindung an GON Trichter, 2 Schläuche DN 100 mm - 1,25 mt lang, 2 ovalen gummitrichter GON-100.

 Boquerel móvil para doble escape, completa de Y con acoplamiento rápido para boquerel oval GON, 2 mangueras \varnothing 100 mm de 1,25 m y 2 boquereles GON-100 en brazos de soporte multiajustables.

cod.	IN	OUT	valv.	notes
GYNMAOG -GON100	2 X 210 X 105 mm	210 X 105 mm	√	QUICK GON



A brand of RO & CO S.p.A.
 via Masaccio, 15
 42124 Reggio Emilia (RE) ITALY
 Tel. +39 0522 1545193
 Fax +39 0522 1546451
 vendite@worky-italy.com
 sales@worky-italy.com
 www.worky-italy.com

GYNMAOG-GON100 - technical datasheet

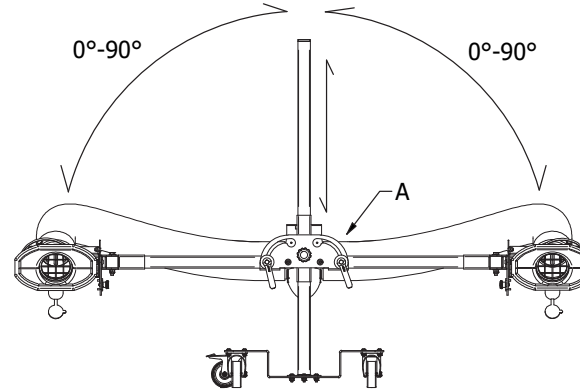
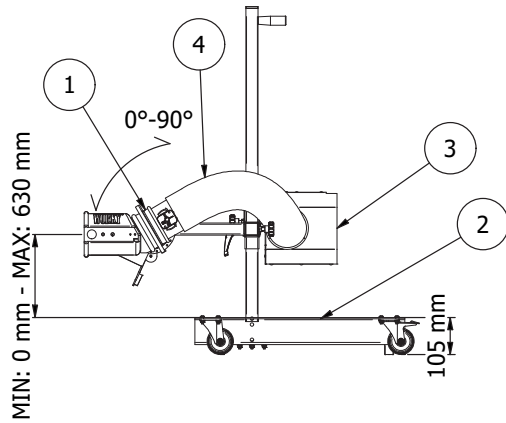

POS.	QTÀ	NUMERO PARTE
1	2	GON-75
2	1	GYNMA-WN
3	1	607.12.029.0/9005
4	2	GTP2-1001.25

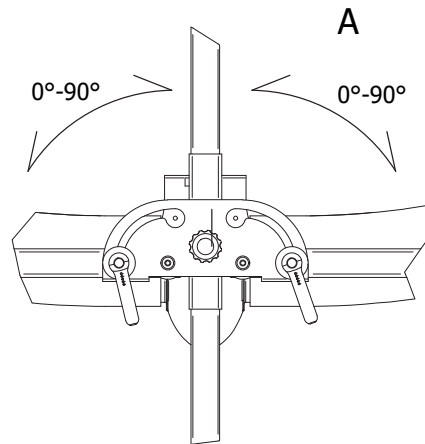
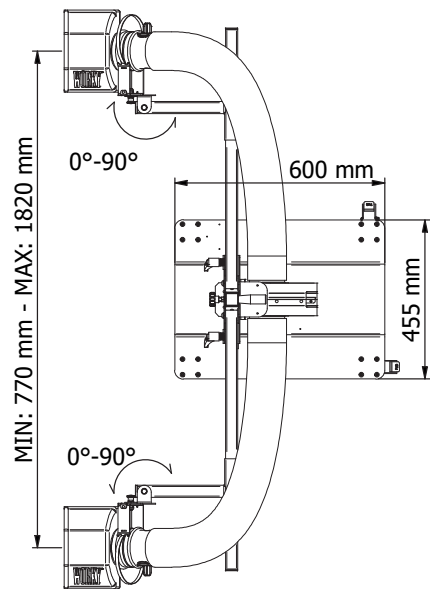

GON-100

100 mm
 210 mm
 105 mm

Rev.00 19/05/2020

È VIETATA LA RIPRODUZIONE TOTALE E/O PARZIALE DEL PRESENTE DISEGNO CHE È DI PROPRIETÀ DI RO & CO SPA PI02492210352
 RO & CO SPA SI RISERVA LA FACOLTÀ DI AGGIORNARE E O MODIFICARE TUTTO O IN PARTE LE PRESENTI SPECIFICHE SENZA PREAVVISO

GYNMAOG-SPORT

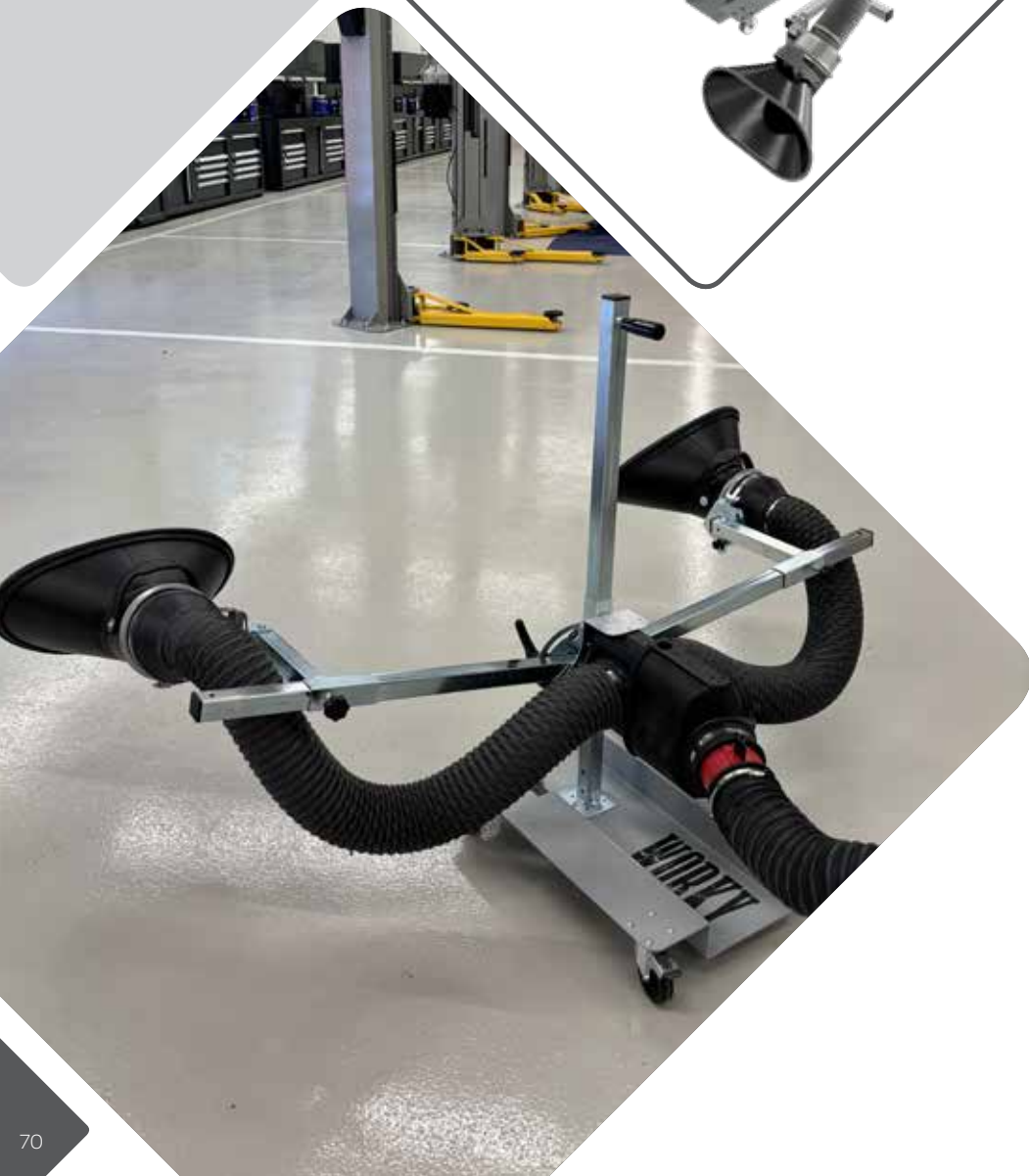

 Bocchetta carrellata per scarichi doppi, completa di bivio ad y con attacco rapido per bocchetta ovale, 2 tubi flessibil \varnothing 100 mm lungh.1,25m e 2 grandi bocche in acciaio da 450x250 mm su braccetti di supporto pluri-regolabili.

 Trolley mounted set for double exhaust pipe with y piece for quick connection to rubber nozzle GON, two x 1,25-m-long hoses and two big sport nozzles 450x250 mm mounted on tilting arms for perfect positioning behind the vehicle.

 Double entonnoir sur chariot pour double pot d'échappement, complet de jonction en Y avec raccord rapide pour GON, 2 flexibles \varnothing 100 mm de 1,25 m de long. et 2 bouches en acier 450x250 mm sur bras de support multi-réglables.

 Behrungsloser wagenmontierter trichter für doppelauspuffrohre komplett mit y stück für direktverbindung an GON Trichter, 2 Schläuche DN 100 mm - 1,25 mt lang, 2 Große Trichtern 450x250 mm aus Stahl.

 Boquerel móvil para doble escape, completa de Y con acoplamiento rápido para boquerel oval GON, 2 mangueras \varnothing 100 mm de 1,25 m y 2 boquereles en acero de 450x250 mm en brazos de soporte multiajustables.

cod.	IN	OUT	valv.	notes
GYNMAOG -100SPORT	2 X 450 X 250 mm	210 X 105 mm	-	QUICK GON



via Masaccio, 15
 42124 Reggio Emilia (RE) ITALY
 Tel. +39 0522 1545193
 vendite@worky-italy.com
 sales@worky-italy.com

www.worky-italy.com

GYNMAOG-SPORT100 - technical datasheet

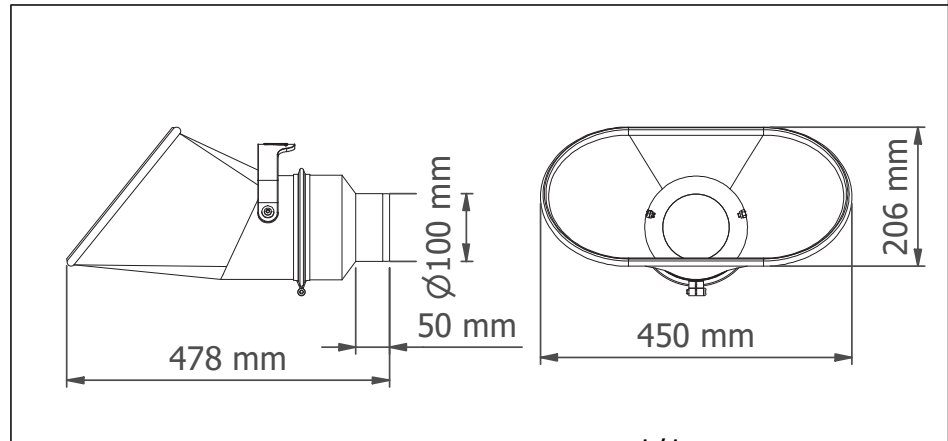
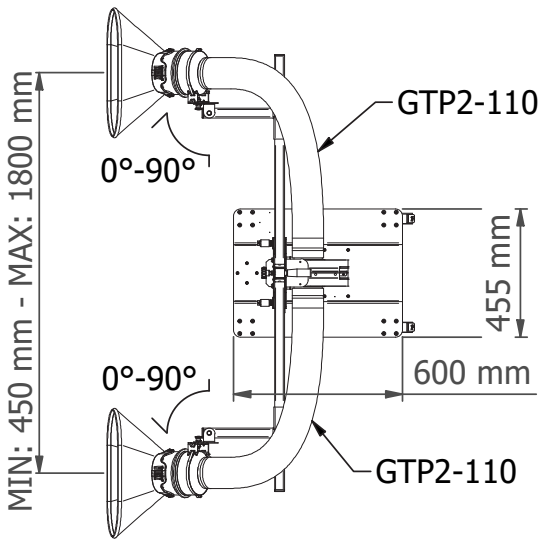
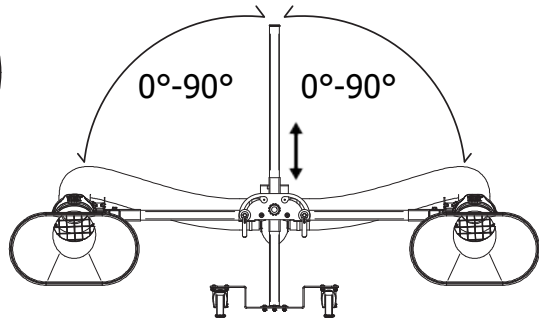
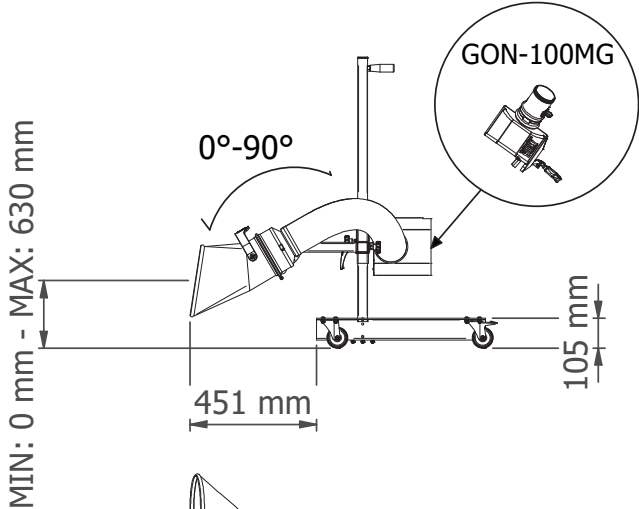

mm 1400x 800 x H 1200
 kg 30

THIS DRAWING IS PROPERTY OF DEA + RO & Co S.p.A. THE COMPLETE OR PARTIAL REPRODUCTION OF THIS DOCUMENT IS FORBIDDEN. THE OWNER RESERVES THE RIGHT TO UPDATE, MODIFY OR AMEND ANY SPECIFICATION WITHOUT PRIOR NOTICE.

Rev.00

1/1

28/06/2023





GYNMA-HT

 Bocchetta carrellata per scarichi doppi, completa di bivio ad Y, 2 tubi lunghi 1,25m resistenti alle alte temperature e 2 bocchette in inox montate su aste indipendenti e pluri-regolabili.

 Trolley mounted nozzle for double exhaust pipes, two high temperature resistant hoses 1,25 mt long each and two stainless steel nozzles mounted on independently adjustable armlets.

 Entonnoir double sur chariot pour vehicules avec double échappement équipé avec un Y, 2 flexibles de 1,25 m résistant à hautes températures et deux entonnoirs en acier inox montés sur bras multi-réglables.

 Wagenmontierte Doppeltrichter für Fahrzeuge mit doppeltem Auspuff. Ausgestattet mit Y-Auslenkung mit je 2 Hoch Temperatur Schläuchen 1,25 m lang und zwei Edelstahl Trichter auf mehrfach verstellbaren, unabhängigen Armen montiert.

 Doble boquerel con carro para vehículos con escape doble. Equipado con desvío en Y con 2 mangueras de 1,25 m de alta temperatura y dos boquereles en acero INOX montados sobre brazos multi-réglables.

cod.	IN	OUT	valv.	notes
GYNMA-100100100HT5	2X (210 x 165 mm)	ø 100 mm	-	500°C
GYNMA-150125125HT5	2X (210 x 165 mm)	ø 150 mm	-	500°C
GYNMA-150125125HT7	2X (210 x 165 mm)	ø 150 mm	-	700°C
GYNMA-150150150HT5	2X (210 x 165 mm)	ø 150 mm	-	500°C
GYNMA-200125125HT3	2X (210 x 165 mm)	ø 200 mm	-	300°C
GYNMA-200125125HT5	2X (210 x 165 mm)	ø 200 mm	-	500°C
GYNMA-200125125HT7	2X (210 x 165 mm)	ø 200 mm	-	700°C



A brand of RO & CO S.p.A.
 via Masaccio, 15
 42124 Reggio Emilia (RE) ITALY
 Tel. +39 0522 1545193
 Fax +39 0522 1546451
 vendite@worky-italy.com
 sales@worky-italy.com
 www.worky-italy.com

GYNMA-100100100HT5 - technical datasheet

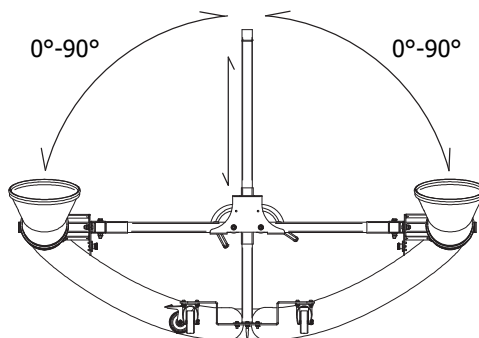
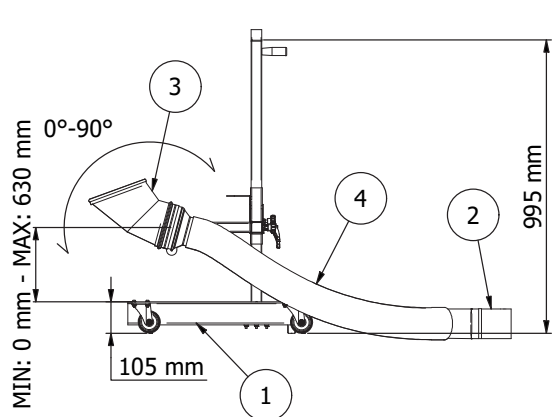

POS.	QTÀ	NUMERO PARTE
1	1	GYNMA-WNHT
2	1	700.16.011.0
3	2	606.12.004.3 + GCR150R100L
4	2	GT5-1001.25

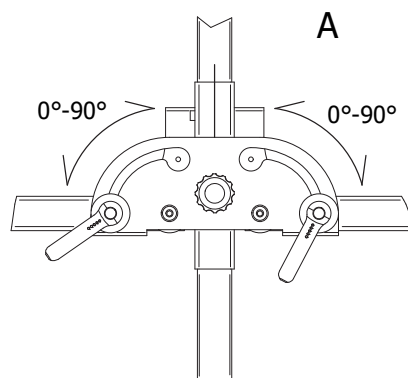
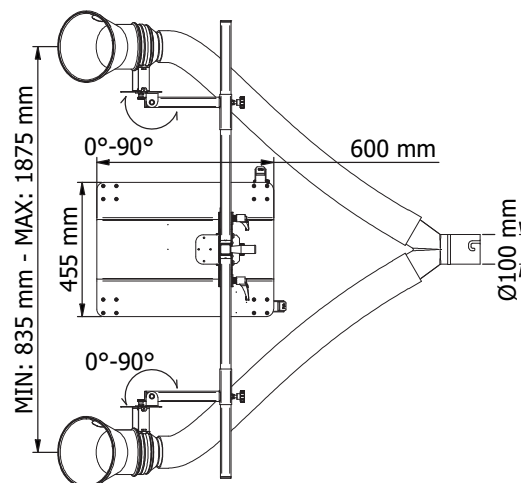

606.12.004.3 + GCR150R100L

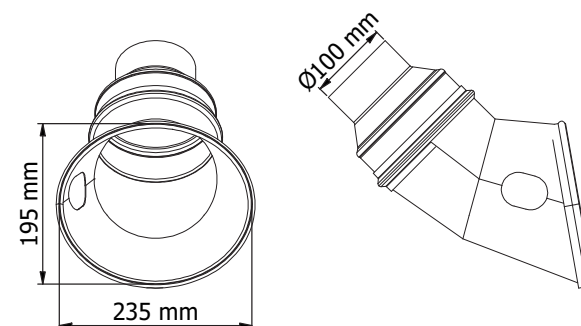

Rev.00

19/05/2020

È VIETATA LA RIPRODUZIONE TOTALE E/O PARZIALE DEL PRESENTE DISEGNO CHE È DI PROPRIETÀ DI RO & CO SPA PI02492210352
 RO & CO SPA SI RISERVA LA FACOLTÀ DI AGGIORNARE E/O MODIFICARE TUTTO O IN PARTE LE PRESENTI SPECIFICHE SENZA PRAVAVISO

GYNMA-DPF



 Bocchetta carrellata per scarichi doppi, completa di bivio ad Y, 2 tubi lunghi 1,25m resistenti alle alte temperature e 2 grandi bocchette in inox con basculamento orizzontale.

 Trolley mounted nozzle for double exhaust pipes, two high temperature resistant hoses 1,25 mt long each and two big stainless steel nozzles horizontally tilting.

 Entonnoir double sur chariot pour vehicules avec double échappement équipé avec un Y, 2 flexibles de 1,25 m résistant à hautes températures et deux grands entonnoirs en acier inox avec oscillation horizontale

 Wagenmontierte Doppeltrichter für Fahrzeuge mit doppeltem Auspuff. Ausgestattet mit Y-Auslenkung mit je 2 Hoch Temperatur Schläuchen 1,25 m lang und zwei Edelstahl Trichter mit horizontaler Bewegung.

 Doble boquerel con carro para vehículos con escape doble. Equipado con desvío en Y con 2 mangueras de 1,25 m de alta temperatura y dos boquereles en acero INOX orientables horizontalmente.

cod.	IN	OUT	height	notes
GYNMA-DPFHT7	2 X (375 x 320 mm)	ø 200 mm	1 meter	700°C
GYNMA-DPFHT1	2 X (375 x 320 mm)	ø 200 mm	1 meter	1000°C
GYNMA2-DPFHT7	2 X (375 x 320 mm)	ø 200 mm	2 meters	700°C



A brand of RO & CO S.p.A
 via Masaccio, 15
 42124 Reggio Emilia (RE) ITALY
 Tel. +39 0522 1545193
 Fax +39 0522 1546451
 vendite@worky-italy.com
 sales@worky-italy.com
 www.worky-italy.com

GYNMA-DPFHT7 - technical datasheet

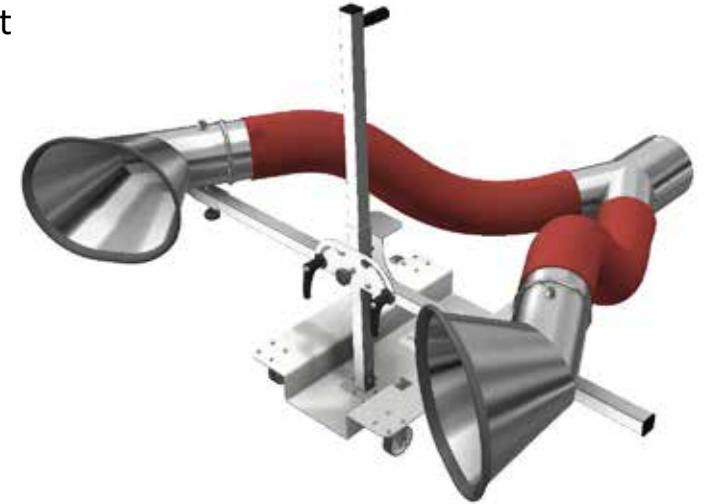

POS.	QTÀ	NUMERO PARTE
1	1	GYNMA-WN + 2x 607.12.007.0
2	2	ZGS150RL
3	2	GMNO-150X CON GUARNIZIONE
5	2	GT7-1501.25
6	1	GDY-200150150

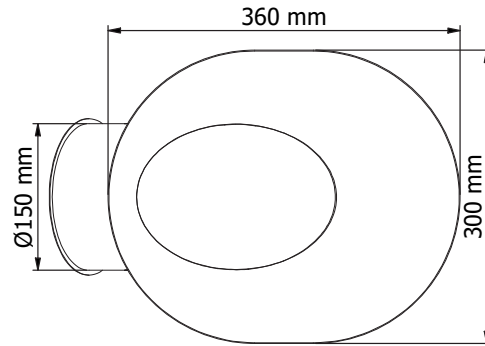

GMNO-150X

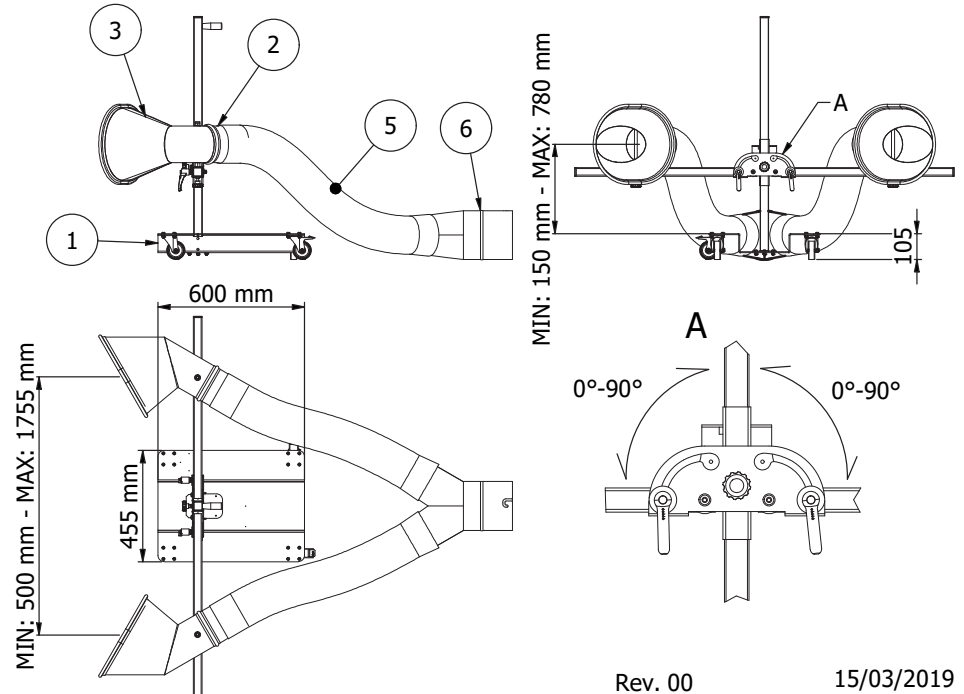
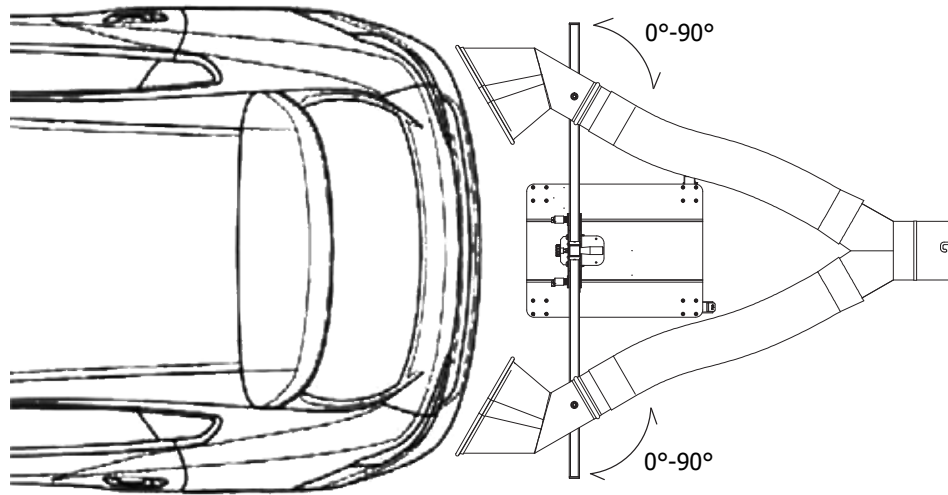

È VIETATA LA RIPRODUZIONE TOTALE E/O PARZIALE DEL PRESENTE DISEGNO CHE È DI PROPRIETÀ DI RO & CO SPA P102492210352
 RO & CO SPA SI RISERVA LA FACOLTÀ DI AGGIORNARE E/O MODIFICARE TUTTO O IN PARTE LE PRESENTI SPECIFICHE SENZA PRAVAVISO

Rev. 00

15/03/2019

GMNT



 Le bocchette carrellate della serie GMNT rappresentano la soluzione prestazionale per l'aspirazione dei gas di scarico quando le temperature salgono o le portate aumentano. Comodamente posizionate su carrelli con ruote girevoli e con freno, si trasportano agevolmente sulla zona di lavoro e non serve metterle a contatto con la marmitta in quanto sono autoportanti. neanche l'operatore deve abbassarsi a regolare la centratura con il tubo di scarico in quanto sono direzionabili dalla comoda maniglia di cui è dotato il carrello.

 The GMNT series of trolley-mounted nozzles are the performance solution for exhaust gas extraction when temperatures rise or flow rates increase. Conveniently positioned on trolleys with swivel wheels and brakes, they are easily transported to the work area and there is no need to put them in contact with the mufflers as they are self-supporting; even the operator does not have to bend down to adjust the centring with the exhaust pipe as they can be directed by the convenient handle on the trolley.

 Les entonnoirs en acier montés sur chariot de la série GMNT sont la solution performante pour l'extraction des gaz d'échappement lorsque les températures augmentent ou que les débits s'accroissent. Positionnées de manière pratique sur des chariots équipés de roues pivotantes et avec freins, elles sont facilement transportées jusqu'à la zone de travail et il n'est pas nécessaire de les mettre en contact avec le pot d'échappement puisqu'elles sont autoportantes. Même l'opérateur n'a pas besoin de se pencher pour régler le centrage avec l'échappement puisqu'il peut être guidé par la poignée pratique du chariot.

 Die fahrbaren Trichter der GMNT-Serie sind die leistungsstarke Lösung für die Abgasabsaugung bei steigenden Temperaturen oder erhöhten Luftmengen. Sie sind bequem auf Wagen mit Schwenkrädern und Bremsen positioniert, lassen sich leicht zum Arbeitsbereich transportieren und müssen nicht mit dem Auspuff in Berührung kommen, da sie selbsttragend sind. Auch der Bediener muss sich nicht bücken, um die Auspuff zur Zentrieren, da sie mit dem praktischen Griff am Wagen gelenkt werden können.

 Los boquereles montados en carro de la serie GMNT son la solución de alto rendimiento para la extracción de gases de escape cuando aumentan las temperaturas o los caudales. Colocadas cómodamente en carros con ruedas giratorias y frenos, se transportan fácilmente a la zona de trabajo y no es necesario ponerlas en contacto con los tubos de escape, ya que son autoportantes. El operador no tiene que agacharse para ajustar el centrado con el tubo de escape, ya que puede dirigirlas mediante la cómoda asa del carro.

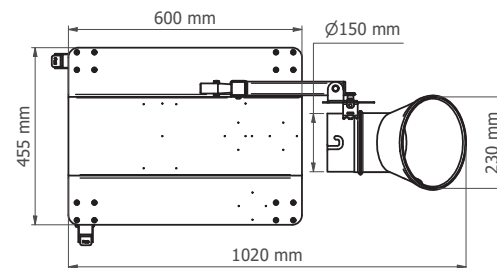
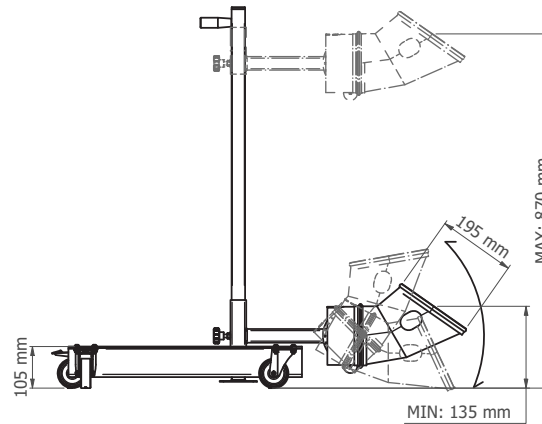

GMNT-HT

 Bocchetta carrellata con doppio freno, bocca di aspirazione in acciaio inox per alte temperature (dimensioni come da disposizioni TÜV) montata su asta basculante da 300 mm.

 Trolley mounted nozzle with double braking wheel, stainless steel suction intake for high temperature (dimensions approved by TÜV) mounted on 300 mm tilting rod.

 Entonnoir installé sur chariot avec 2 freins, prise d'aspiration en acier inox pour hautes températures (dimensions approuvées par le TÜV) monté sur pied avec bras oscillant de 300 mm.

 Wagenmontierttrichter mit Doppelbremsrädern, Edelstahl-Saugaufnahme für Hochtemperatur (Abmessungen zugelassen durch TÜV) auf 300 mm Schwenkarm montiert.

 Boquerel montado su carro con doble rueda con freno, boca en acero inox (aprovada TÜV) montada su brazo oscilante de 300 mm de longitud.

cod.	IN	OUT	quick coup.	notes
GMNT-100HT	210 x 165 mm	ø 100 mm	-	INOX
GMNT-125HT	210 x 165 mm	ø 125 mm	-	INOX
GMNT-150HT	210 x 165 mm	ø 150 mm	√	INOX



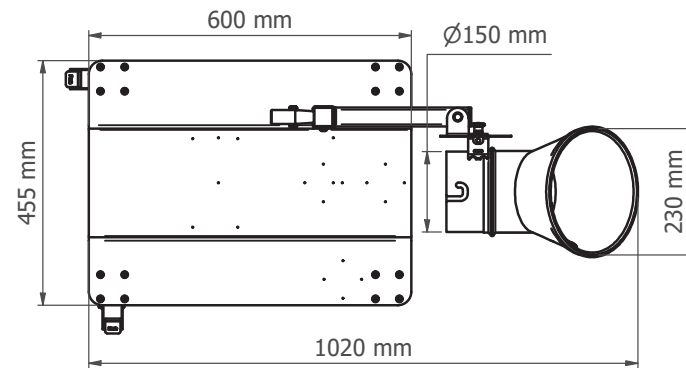
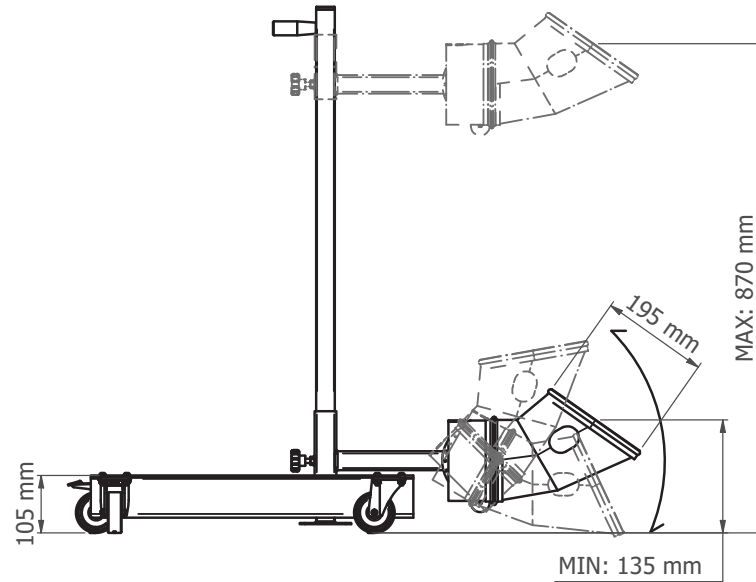
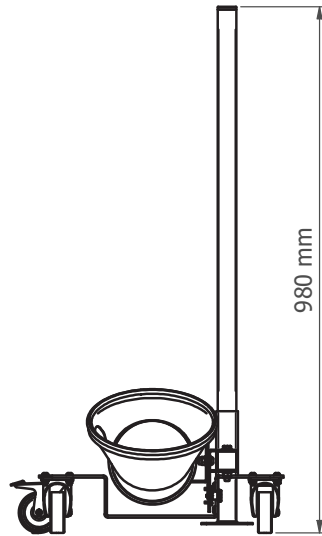

A brand of RO & CO S.p.A
via Masaccio, 15
42124 Reggio Emilia (RE) ITALY
Tel. +39 0522 1545193
Fax +39 0522 1546451
vendite@worky-italy.com
sales@worky-italy.com
www.worky-italy.com

GMNT-150HT - technical datasheet





GMNT-MAN

 Bocchetta carrellata con doppio freno, grande bocca di aspirazione in acciaio inox orientata lateralmente montata su asta basculante da 700 mm.

 Trolley mounted nozzle with double braking wheel, big stainless steel suction intake laterally oriented and mounted on 700 mm tilting rod.

 Entonnoir installé sur chariot avec 2 freins, grande prise d'aspiration en acier inox orienté latéralement et monté sur bras oscillant de 700 mm.

 Wagenmontierttrichter mit Doppelbremsrädern, Großes und seitlich orientierter Edelstahl-Saugaufnahme auf 700 mm Schwenkarm montiert.

 Boquerel montado su carro con doble rueda con freno, grande boca aspirante en acero inox orientada lateralmente y montada sobre brazo basculante de 700 mm de longitud.

cod.	IN	OUT	quick coup.	notes
GMNT-100MAN	375 x 320 mm	ø 100 mm	-	INOX
GMNT-125MAN	375 x 320 mm	ø 125 mm	-	INOX
GMNT-150MAN	375 x 320 mm	ø 150 mm	√	INOX



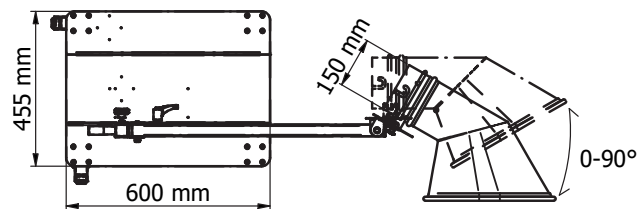
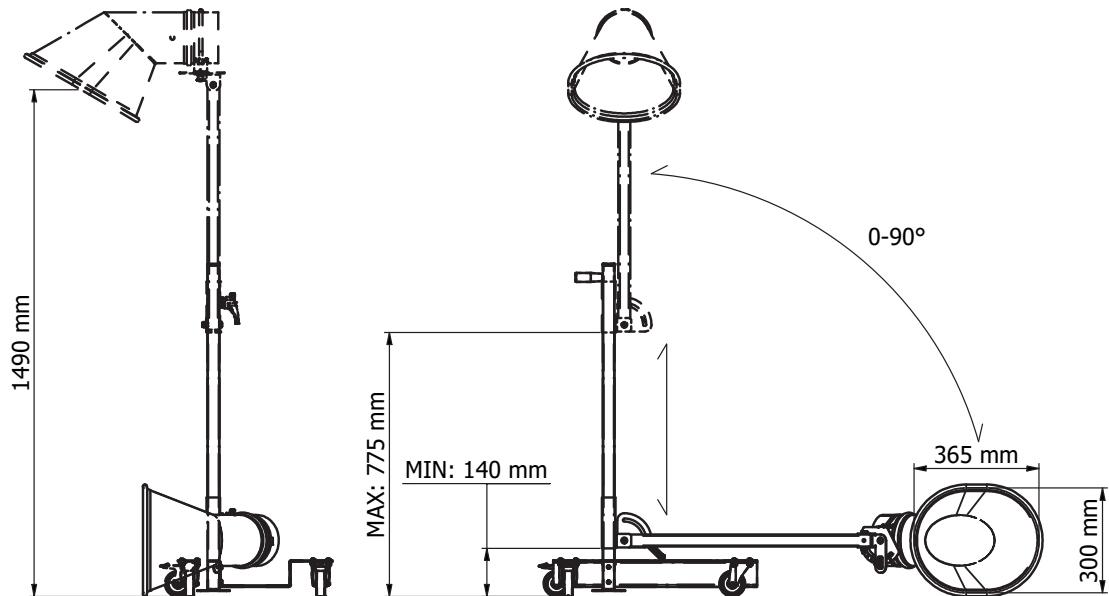

A brand of RO & CO S.p.A.
via Masaccio, 15
42124 Reggio Emilia (RE) ITALY
Tel. +39 0522 1545193
Fax +39 0522 1546451
vendite@worky-italy.com
sales@worky-italy.com
www.worky-italy.com

GMNT-150MAN - technical datasheet



GMINT-SENNA

 Bocchetta carrellata con doppio freno, grande bocca di aspirazione in acciaio inox orientata verso il basso e montata su asta basculante da 700 mm. Colore bianco McLaren.

 Trolley mounted nozzle with double braking wheel, big stainless steel suction intake downwards oriented and mounted on 700 mm tilting rod. White McLaren colour.

 Entonnoir installé sur chariot avec 2 freins, grande prise d'aspiration en acier inox orienté vers le bas et monté sur bras oscillant de 700 mm. Couleur blanc McLaren.

 Wagenmontierttrichter mit Doppelbremsrädern, Großes und nach unten gerichteter Edelstahl-Saugaufnahme auf 700 mm Schwenkarm montiert. Farbe McLaren Weiß.

 Boquerel montado su carro con doble rueda con freno, grande boca aspirante en acero inox orientada hacia abajo y montada sobre brazo basculante de 700 mm de longitud. Color blanco McLaren.

cod.	IN	OUT	notes
GMINT-150SENN/9003	375 x 320 mm	ø 150 mm	WHITE

WORKY
www.worky-italy.com

A brand of RO & Co S.p.A.
via Masaccio, 15
42124 Reggio Emilia (RE) ITALY
Tel. +39 0522 1545193
Fax +39 0522 1546451
vendite@worky-italy.com
sales@worky-italy.com

GMNT-150SENNA - technical datasheet

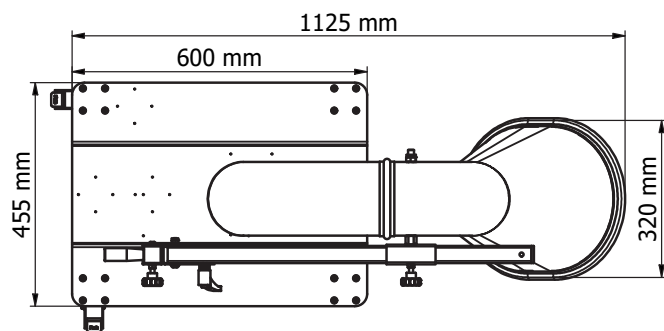
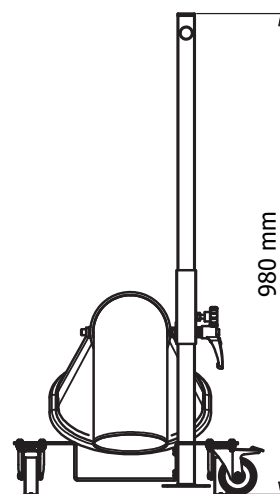
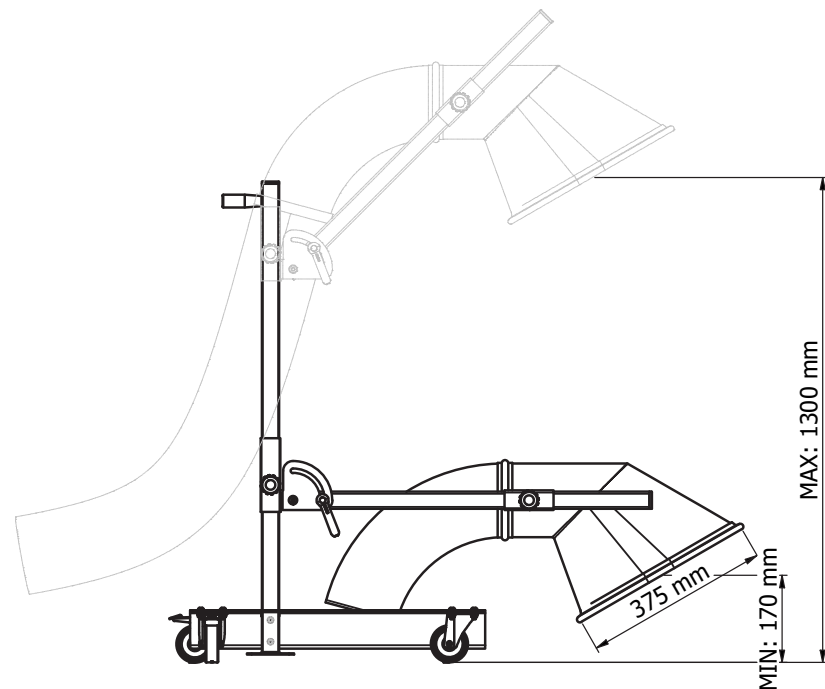





GMNT-DAF

 Bocchetta carrellata con doppio freno, bocca rettangolare di aspirazione in acciaio per andare sottoscocca, montata su asta basculante da 700 mm.

 Wheel-mounted, double-brake, rectangular steel suction nozzle to go underneath the body, mounted on 700 mm tilting rod.

 Entonnoir installé sur chariot avec 2 freins, prise d'aspiration rectangulaire en acier, pour passer sous la carrosserie, montée sur une tige basculante de 700 mm.

 Wagenmontierttrichter mit Doppelbremsrädern, rechteckige Stahlsaugaufnahme zum Unterfahren der Karosserie, auf 700 mm Schwenkarm montiert.

 Boquerel montado su carro con doble rueda con freno, boca aspirante rectangular en acero para pasar por debajo de la carrocería, montada sobre brazo basculante de 700 mm de longitud.



cod.	IN	OUT	valv.	notes
GMNT-150DAF	560 x 150 mm	ø 150 mm	-	-

WORKY

www.worky-italy.com

A brand of RO & Co S.p.A.
via Masaccio, 15
42124 Reggio Emilia (RE) ITALY
Tel. +39 0522 1545193
vendite@worky-italy.com
sales@worky-italy.com

GMNT-150DAF - technical datasheet

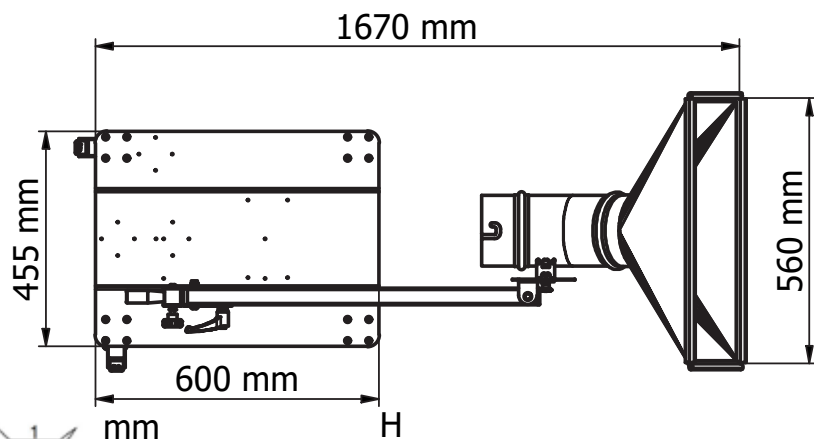
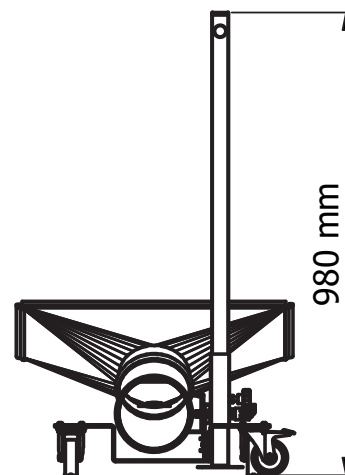
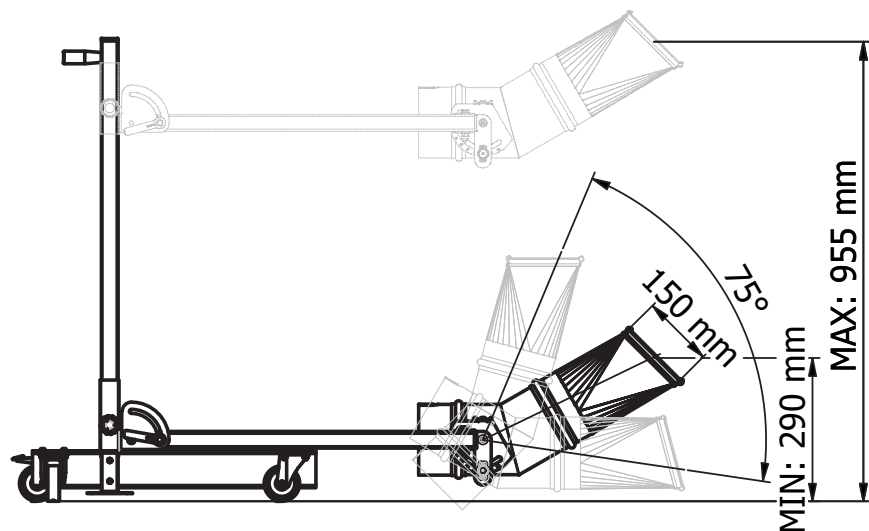

KG

GMNT-400200

 Bocchetta carrellata con doppio freno, bocca di aspirazione in acciaio zincato di generose dimensioni e regolabile in altezza.

 Trolley mounted nozzle with double braking wheels, galvanized steel suction intake with big dimensions and adjustable in height.

 Entonnoir installé sur chariot avec 2 freins, prise d'aspiration en tôle galvanisée de grand dimensions et réglable en hauteur.

 Wagenmontierttrichter mit Doppelbremsrädern, Höhenregulierbarer Groß-Stahlblech Saugaufnahme.

 Boquerel montado su carro con doble rueda con freno, boca en chapa galvanizada de grandes dimensiones y regulable en altura.

cod.	IN	OUT	valv.	notes
GMNT-400200	400 x 370 mm	ø 200 mm	-	-



via Masaccio, 15
 42124 Reggio Emilia (RE) ITALY
 Tel. +39 0522 1545193
 vendite@worky-italy.com
 sales@worky-italy.com

www.worky-italy.com

GMNT-400200 - technical datasheet

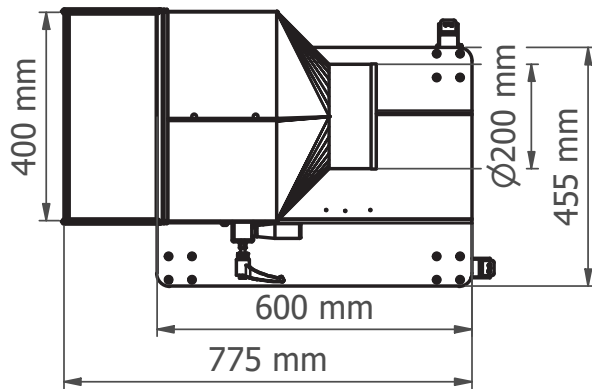
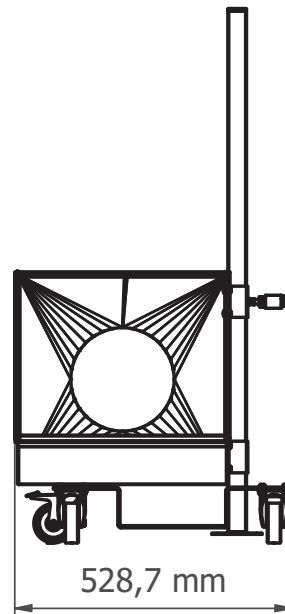
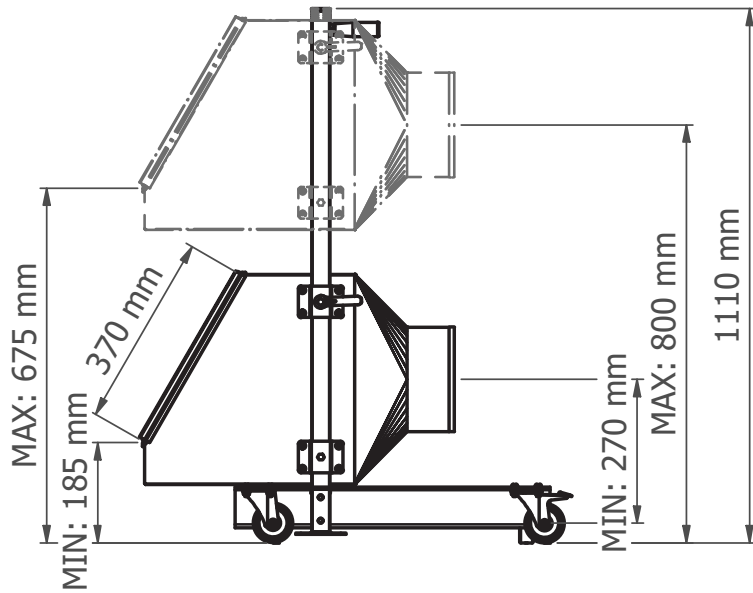

mm x x H
 kg 20

THIS DRAWING IS PROPERTY OF DEA + RO & Co S.p.A. THE COMPLETE OR PARTIAL REPRODUCTION OF THIS DOCUMENT IS FORBIDDEN. THE OWNER RESERVES THE RIGHT TO UPDATE, MODIFY OR AMEND ANY SPECIFICATION WITHOUT PRIOR NOTICE.

Rev.00

1/1
 04/10/2022

GMNT-E6K7B



 Bocchetta carrellata regolabile in altezza studiata per aspirare i gas di scarico dai veicoli Mercedes ACTROS euro 6. Collegamento al tubo flessibile di diam. 150 mm.

 Height-adjustable wheeled nozzle designed to extract exhaust fumes from Mercedes ACTROS euro 6 vehicles. Connection to 150 mm diameter hose.

 Entonnoir sur chariot, réglable en hauteur, conçue pour aspirer les gaz d'échappement des véhicules Mercedes ACTROS euro 6. Raccordement à un flexible de 150 mm de diamètre.

 Höhenverstellbare Wagenmontiertertrichter zum Absaugen der Abgase von Mercedes ACTROS Euro 6 Fahrzeugen. Schlauchanschluss DN 150 mm.

 Boquerel montado su carro, altura regulable, diseñada para aspirar los gases de escape de los vehículos Mercedes ACTROS euro 6. Conexión a manguera de 150 mm de diámetro.



cod.	IN	OUT	notes
GMNT-E6KTB	705 x 446 mm	ø 150 mm	MB ACTROS



A brand of RO & CO S.p.A
via Masaccio, 15
42124 Reggio Emilia (RE) ITALY
Tel. +39 0522 1545193
Fax +39 0522 1546451
vendite@worky-italy.com
sales@worky-italy.com
www.worky-italy.com

GMNT-E6K7B - technical datasheet

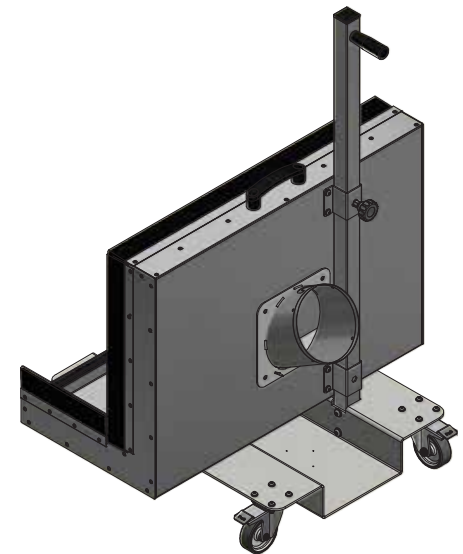
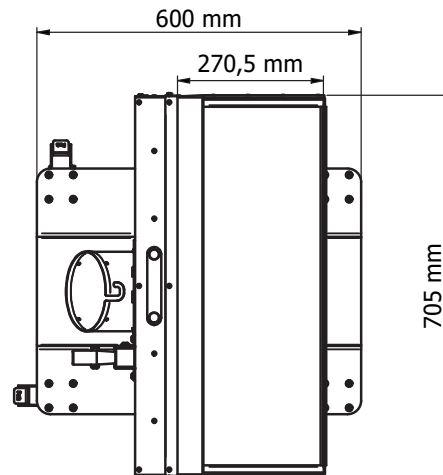
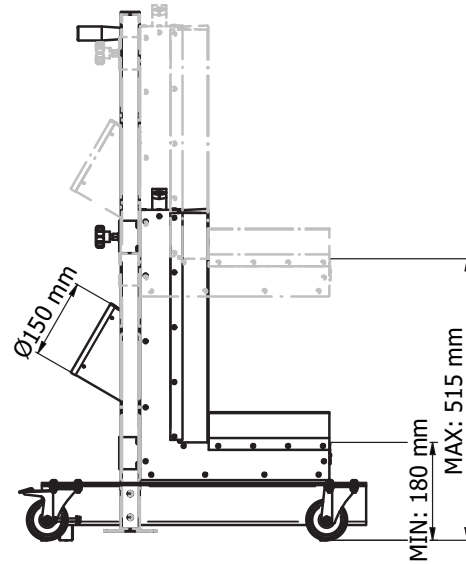
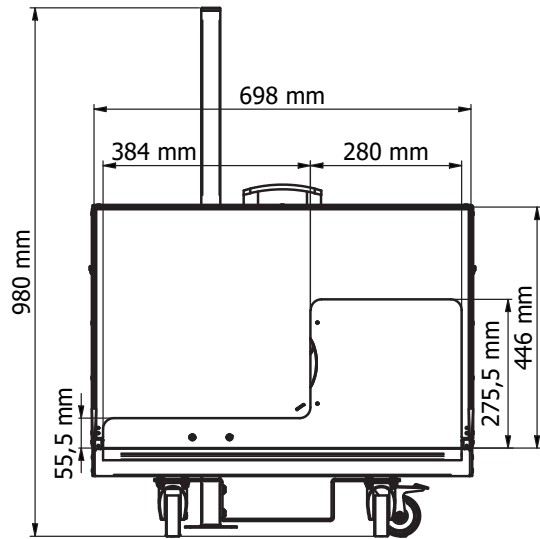



È VIETATA LA RIPRODUZIONE TOTALE E/O PARZIALE DEL PRESENTE DISEGNO CHE È DI PROPRIETÀ DI RO & CO SPA PI02492210352
RO & CO SPA SI RISERVA LA FACOLTÀ DI AGGIORNARE E/O MODIFICARE TUTTO O IN PARTE LE PRESENTI SPECIFICHE SENZA PRAVAVISO.

Rev.01

24/07/2020

GMNT-GTL

 Bocchetta snodata touchless montata su carrello per il collegamento ad un flessibile Ø 150 mm e adatta ad aspirare da tubi di scarico centrali dei camion anche in presenza della fossa di ispezione. Estensione massima 1,2 m.

 Articulated touchless nozzle mounted on trolley for hose connection Ø 150 mm and suitable to catch the central exhaust pipes of the trucks even in presence of the inspection pit. Max extension 1,2 m.

 Entonnoir articulée sans contact montée sur un chariot pour flexible de Ø 150 mm et apte à capter les pots d'échappement centraux des camions, même en présence de la fosse d'inspection. Extension maximale de 1,2 m.

 Berührungsloser Gelenktrichter, für Schlauch DN 150 mm und geeignet um mittleren Auspuffrohre von LKWs zu erfassen, selbst wenn eine Inspektionsgrube vorhanden ist. Maximale Ausdehnung von 1,2 m.

 Boquerel articulado sin contacto montado sobre carro para conectarse a una manguera de Ø 150 mm y adecuada para captar los escapes centrales de los camiones también con foso de inspección. Extensión máxima 1,2 m.

cod.	IN	OUT	valv.	notes
GMNT-GTL	210 x 165 mm	ø 150 mm	√	200°C



A brand of RO & CO S.p.A
via Masaccio, 15
42124 Reggio Emilia (RE) ITALY
Tel. +39 0522 1545193
Fax +39 0522 1546451
vendite@worky-italy.com
sales@worky-italy.com
www.worky-italy.com

GMNT-GTL _technical_datasheet

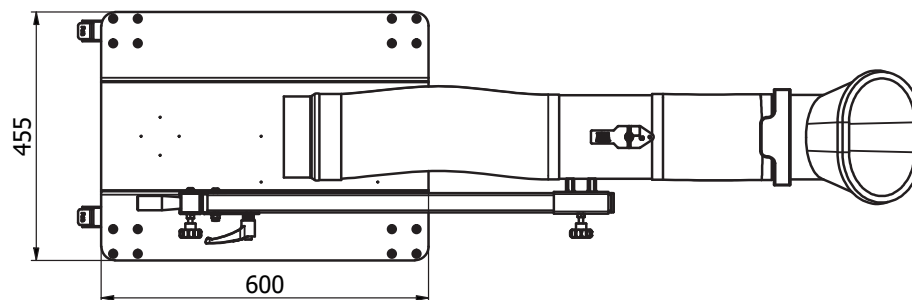
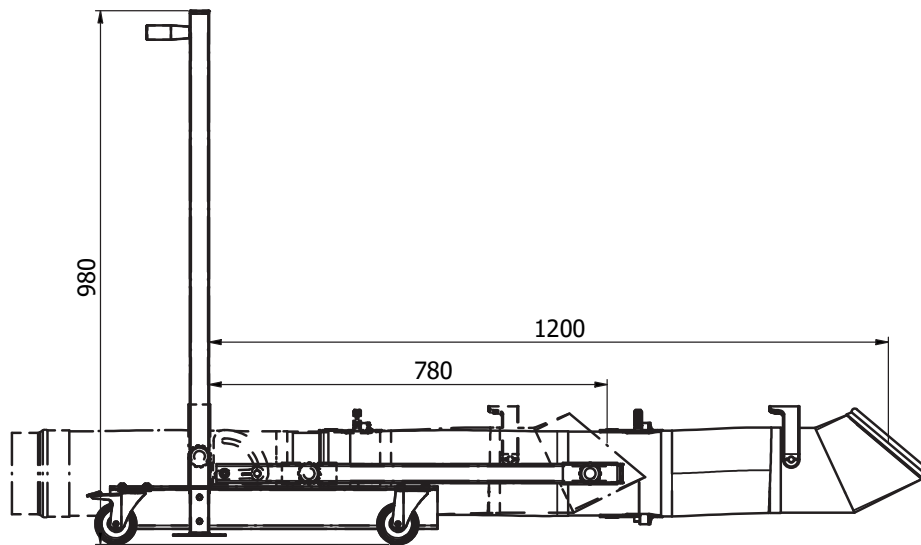
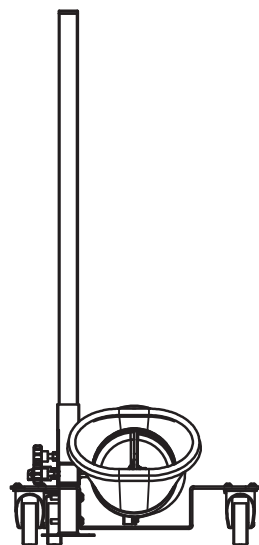



via Masaccio, 15
 42124 Reggio Emilia (RE) ITALY
 Tel. +39 0522 1545193
 vendite@worky-italy.com
 sales@worky-italy.com

www.worky-italy.com

GMNT2-700200 - technical datasheet

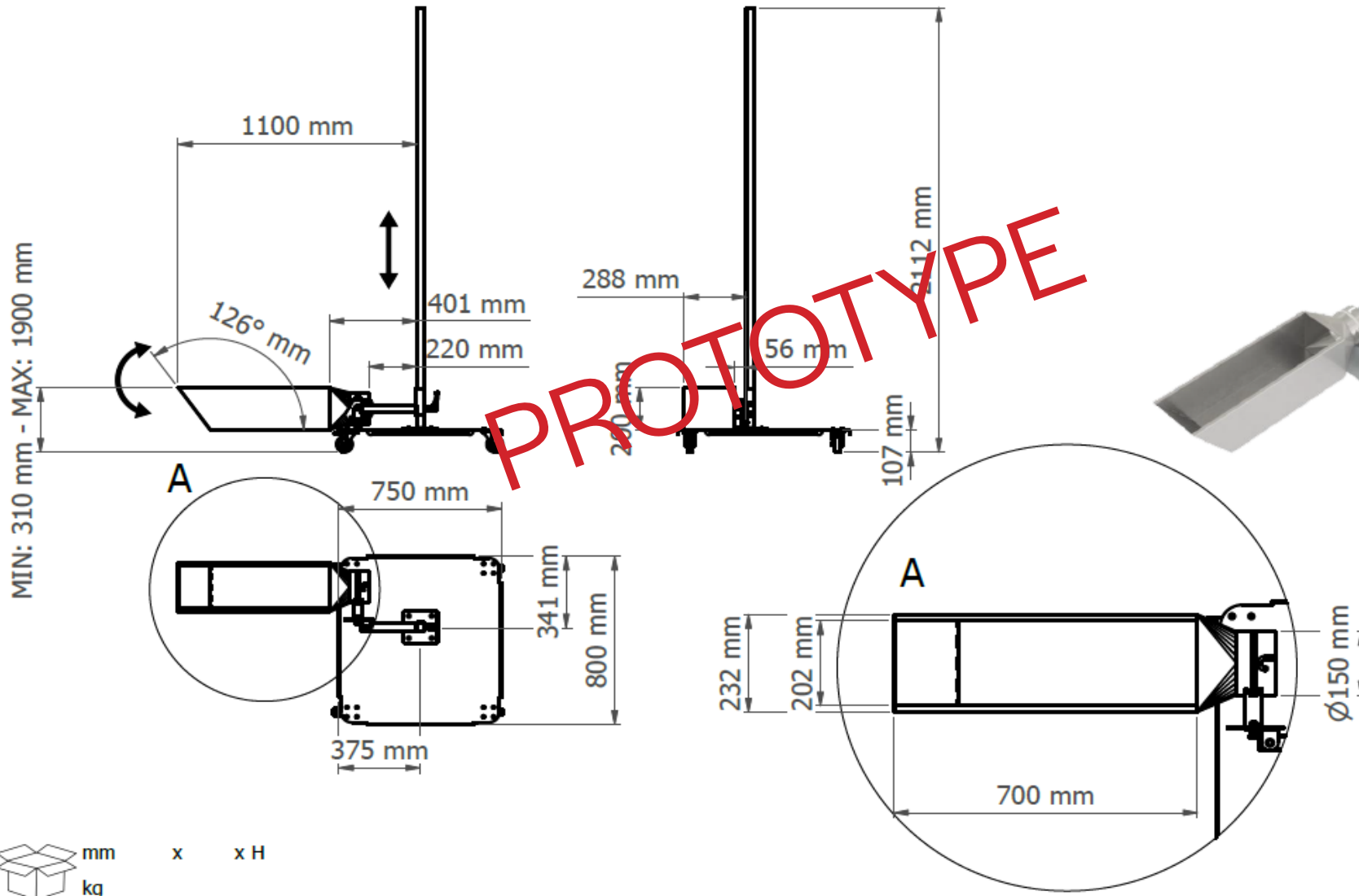

mm x x H
 kg



via Masaccio, 15
 42124 Reggio Emilia (RE) ITALY
 Tel. +39 0522 1545193
 vendite@worky-italy.com
 sales@worky-italy.com

www.worky-italy.com

GMNT-200AU - technical datasheet

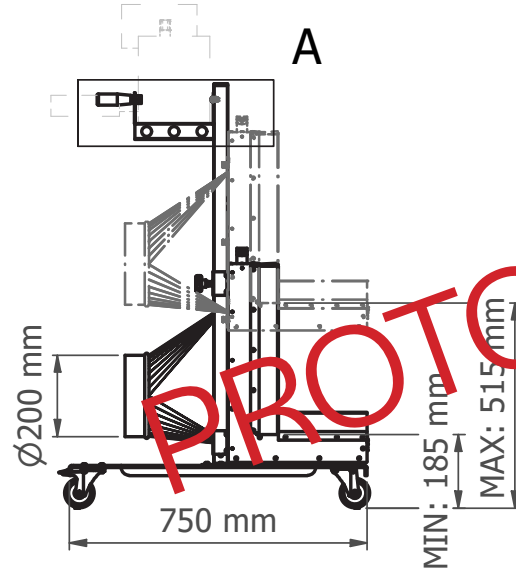
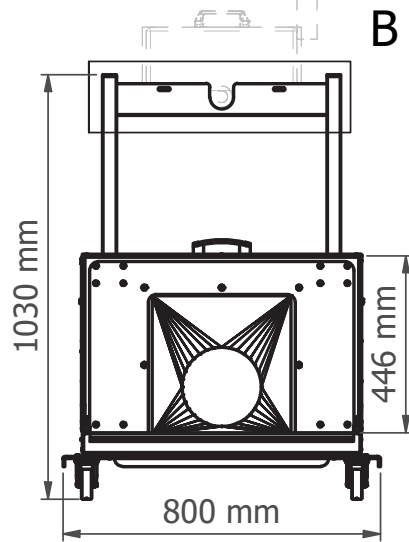

PROTOTYPE

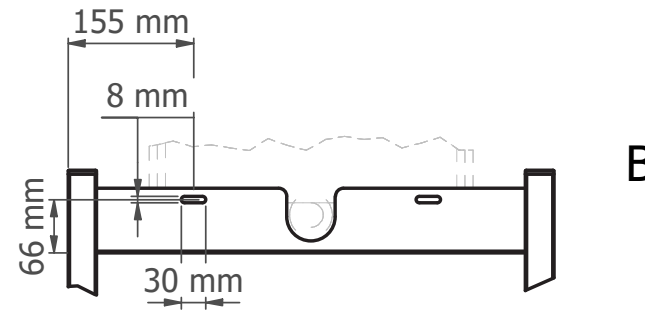
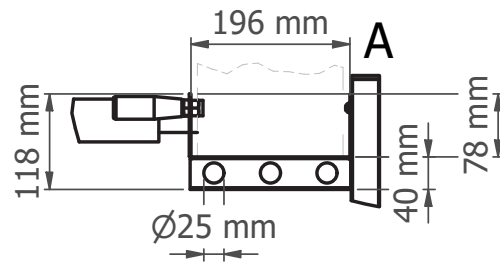
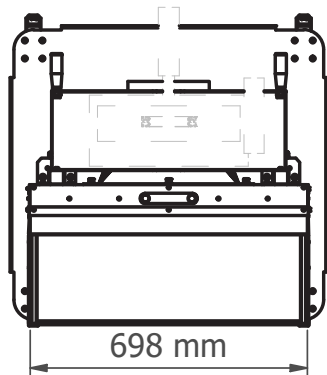

CAT. ARROT.



SCAN THE QR CODE
DOWNLOAD THE
CATALOGUE



CAT. ASPIRAT.



SCAN THE QR CODE
DOWNLOAD THE
CATALOGUE



CAT. ACCESSORI



SCAN THE QR CODE
DOWNLOAD THE
CATALOGUE



WORKY®

WORKY®

WORKY Headquarters and Production

Via Masaccio, 15 - Z.I. Mancasale
42124 - REGGIO EMILIA (RE) ITALY

Tel. +39-0522-1545193

Fax. +39-0522-1546451

sales@worky-italy.com

vendite@worky-italy.com

www.worky-italy.com

WORKY North America Inc.

112 South Tryon Street
Suite 1130 Charlotte, North Carolina
28284 USA

Tel +1 (305) 705 5017

www.deaworkyna.com



Inquadra il QR Code e scopri il nostro sito!
Frame the QR Code to discover our website!



Seguici su / Follow us on:



QUALITY CERTIFIED ISO 9001:2015